

DATE	APRIL 1, 2020	OUTLINE DIMENSIONS	MOTOR TYPE:	AEHH8N
CATALOG NO.:	EP0404		3-PHASE INDUCTION MOTOR	FRAME NO.

Pole	HP	kW	Hz	VOLT	r/min (rpm)
4	40	30	60	230/460	1800

Ins	Rating	Dimension in	Approx Weight	Bearings	
F	CONT.	inch	③ 539 lbs	DE: 6312	NDE: 6310

Totally Enclosed Fan-Cooled Type. Squirrel-cage Rotor.

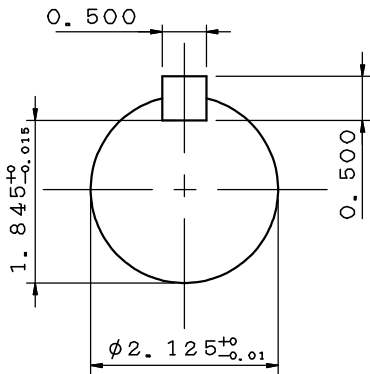
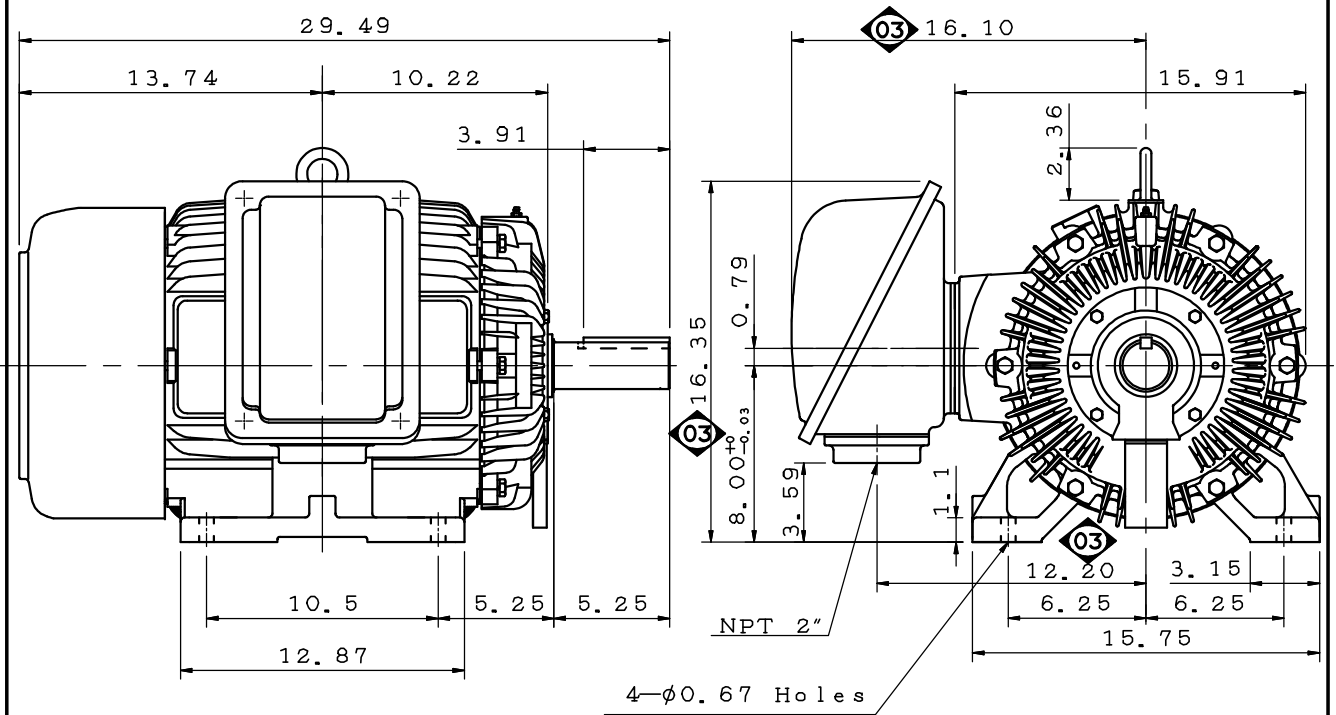

③ 12.16.19 Enlarge T-BOX volume. C. T. CHEN

DWG.	J. F. Chen	06.27.19	TECO Westinghouse	DWG NO.	31057M095033
CHKD.	M. C. JENG	06.28.19			
APPD.	M. C. JENG	06.28.19			

TECO Westinghouse

ISSUED 8/15/2014	PERFORMANCE DATA 3-PHASE INDUCTION MOTOR	ENCLOSURE TEFC
TYPE AEHH8N		CATALOG# EP0404

NAMEPLATE INFORMATION

OUTPUT		POLE	FRAME SIZE	VOLTAGE	HZ	RATED AMBIENT	INS. CLASS	NEMA DESIGN	TIME RATING	SERVICE FACTOR
HP	KW									
40	29.8	4	324T	230/460	60	40°C	F	B	CONT.	1.15

VARIABLE FREQUENCY DRIVE SERVICE

VARIABLE TORQUE				OHMS/PHASE EQUIVALENT WYE CIRCUIT (AT RATED OPERATING TEMPERATURE 25°C)				
HZ	HP	RPM	TORQUE (lb-ft)	R1	R2	X1	X2	X _m
3~60	0.005~40	90~1800	0.292~118.7	0.0844	0.1734	0.4822	1.0764	23.315

CONSTANT TORQUE				CONSTANT HORSEPOWER			
HZ	HP	RPM	TORQUE (lb-ft)	HZ	HP	RPM	TORQUE (lb-ft)
6~60	4~40	180~1800	118.7	60~90	40	1800~2700	118.7~79.13

TYPICAL PERFORMANCE

FULL LOAD RPM	EFFICIENCY				POWER FACTOR			SOUND PRESSURE LEVEL @ 3 FT Db(A)
	FULL LOAD		3/4 LOAD %	1/2 LOAD %	FULL LOAD %	3/4 LOAD %	1/2 LOAD %	
	MIN.%	NOM.%						
1770	93	94.1	94.5	94.5	86	84.5	78.5	74

CURRENTS									NEMA KVA CODE LETTER	SAFE STALL TIME IN SECONDS	
NO LOAD			FULL LOAD			LOCKED ROTOR				COLD	HOT
AT 208 VOLT	AT 230 VOLT	AT 460 VOLT	AT 208 VOLT	AT 230 VOLT	AT 460 VOLT	AT 208 VOLT	AT 230 VOLT	AT 460 VOLT			
19.00	21.20	10.6	102.39	92.60	46.30	524.5	580.0	290	G	25	18

TORQUE				INERTIA			ACCEL TIME (DOL)		ALLOWABLE STARTS PER HOUR	
FULL LOAD (lb-ft)	LOCKED ROTOR %FLT	PULL UP %FLT	BREAK DOWN %FLT	ROTOR WR ² (lb-ft ²)	NEMA LOAD WK ² (lb-ft ²)	MAX ALLOWABLE WK ² (lb-ft ²)	NEMA LOAD WK ² Sec	MAX ALLOWABLE WK ² Sec	COLD	HOT
118.70	205	170	220	8.624	189	375	4.91	9.52	2	1

APPROVED:	M. PRATER	DRAWING NO.	31057EP0404	REVISION:	1
-----------	------------------	-------------	--------------------	-----------	----------

DATE:
December 28, 2010

CONNECTION DIAGRAM

CATALOG NO.:
EP0404



SCHEMATIC - Δ / Y CONNECTION

ACROSS THE LINE CONNECTION

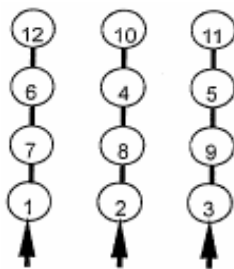

LINE
230 VOLT CONNECTION

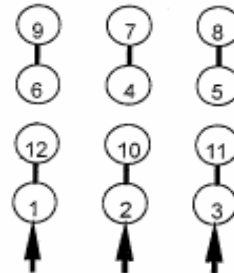

LINE
460 VOLT CONNECTION

***CONTACT TWMC IF YOU HAVE ANY QUESTIONS REGARDING THE MOTOR CONNECTION.**

PH: 1-800-873-8326