

TYPE	OUTPUT		POLE	TIME RATING	VOLTAGE V	Hz	SYN SPEED R.P.M
	HP.	KW.					
AEH8N	100	74.6	6	CONT.	230/460	60	1200

TOTALLY ENCLOSED FAN-COOLED TYPE, SQUIRREL-CAGE ROTOR

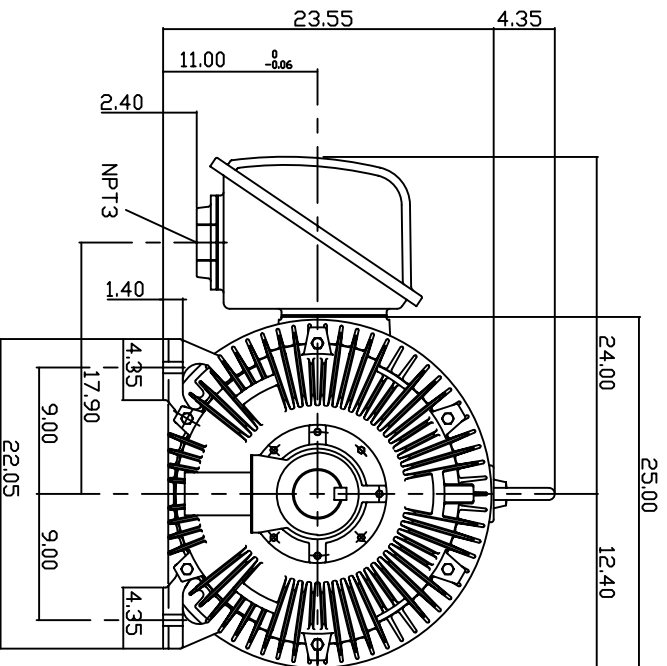
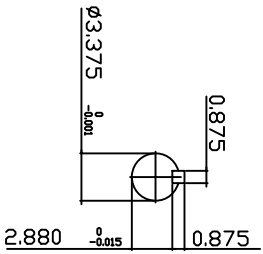
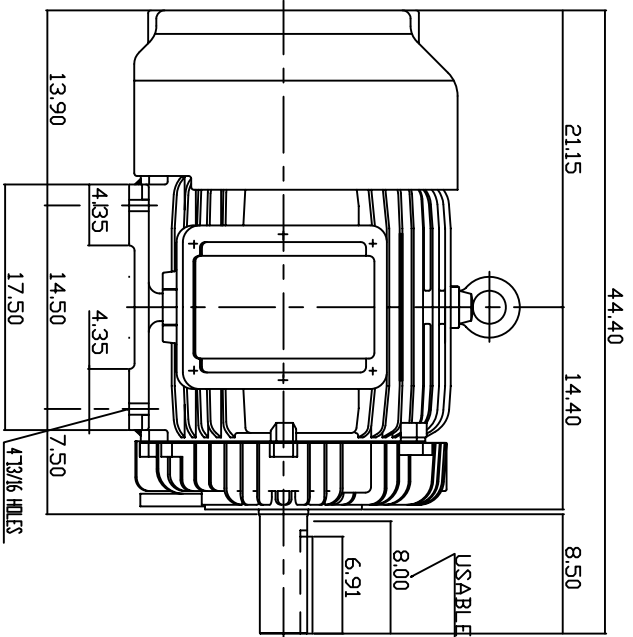

NOTE:

1. DIMENSIONS IN INCH
2. FRAME NO. 444T
3. F CLASS INSULATION, S.F.1.15
4. FOR BELTED SERVICE
5. ENCLDURE: IP55
6. BEARING SIZE: DRIVE END: NU318
NON-DRIVE END: 6316
7. APPROX. WEIGHT: 1600 LBS

TW-56C

DWN. N.QIN	JAN 13 2005
CHKD. H.HUANG	JAN 13 2005
APPD. C.WANG	JAN 13 2005

DATE 20050617
CATALOG # EP1006R

OUTLINE DIMENSIONS
3-PHASE INDUCTION MOTOR



DWG NO. 3A040Y599
REV. 00

TECO Westinghouse

ISSUED 8/15/2014	PERFORMANCE DATA 3-PHASE INDUCTION MOTOR	ENCLOSURE TEFC
TYPE AEHH8N		CATALOG# EP1006R

NAMEPLATE INFORMATION

OUTPUT		POLE	FRAME SIZE	VOLTAGE	HZ	RATED AMBIENT	INS. CLASS	NEMA DESIGN	TIME RATING	SERVICE FACTOR
HP	KW									
100	74.6	6	444T	230/460	60	40°C	F	B	CONT.	1.15

VARIABLE FREQUENCY DRIVE SERVICE

VARIABLE TORQUE				OHMS/PHASE EQUIVALENT WYE CIRCUIT (AT RATED OPERATING TEMPERATURE 25°C)				
HZ	HP	RPM	TORQUE (lb-ft)	R1	R2	X1	X2	X _m
3~60	0.0125~100	60~1200	1.09~444	0.0778	0.0497	0.5102	0.978	16.2

CONSTANT TORQUE				CONSTANT HORSEPOWER			
HZ	HP	RPM	TORQUE (lb-ft)	HZ	HP	RPM	TORQUE (lb-ft)
6~60	10~100	118~1200	444	60~90	100	1200-1800	444~296

TYPICAL PERFORMANCE

FULL LOAD RPM	EFFICIENCY				POWER FACTOR			SOUND PRESSURE LEVEL @ 3 FT Db(A)
	FULL LOAD		3/4 LOAD %	1/2 LOAD %	FULL LOAD %	3/4 LOAD %	1/2 LOAD %	
	MIN.%	NOM.%						
1182	94.1	95	94.5	93.6	82.5	80	73	77

CURRENTS									NEMA KVA CODE LETTER	SAFE STALL TIME IN SECONDS	
NO LOAD			FULL LOAD			LOCKED ROTOR				COLD	HOT
AT 208 VOLT	AT 230 VOLT	AT 460 VOLT	AT 208 VOLT	AT 230 VOLT	AT 460 VOLT	AT 208 VOLT	AT 230 VOLT	AT 460 VOLT			
79.70	96.00	48	263.17	238.00	119.00	1311.3	1450.0	725	G	21	15

TORQUE				INERTIA			ACCEL TIME (DOL)		ALLOWABLE STARTS PER HOUR	
FULL LOAD (lb-ft)	LOCKED ROTOR %FLT	PULL UP %FLT	BREAK DOWN %FLT	ROTOR WR ² (lb-ft ²)	NEMA LOAD WK ² (lb-ft ²)	MAX ALLOWABLE WK ² (lb-ft ²)	NEMA LOAD WK ² Sec	MAX ALLOWABLE WK ² Sec	COLD	HOT
444.00	140	110	230	56	1181	2953	6.00	14.58	2	1

APPROVED:	M. PRATER	DRAWING NO.	31057EP1006	REVISION:	1
-----------	------------------	-------------	--------------------	-----------	----------

DATE:
December 2, 2005

CONNECTION DIAGRAM

CATALOG NO.:
EP1006R

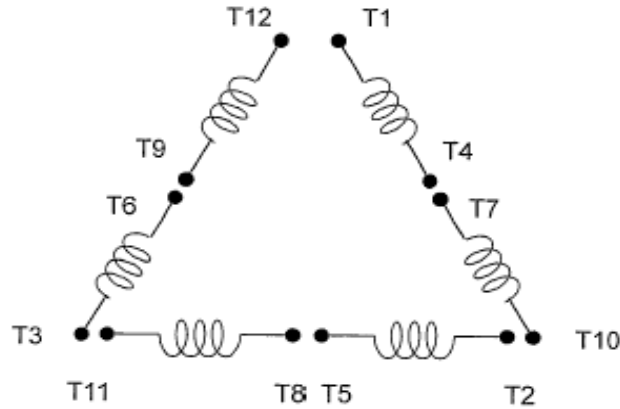

SCHEMATIC - Δ / Y CONNECTION

ACROSS THE LINE CONNECTION

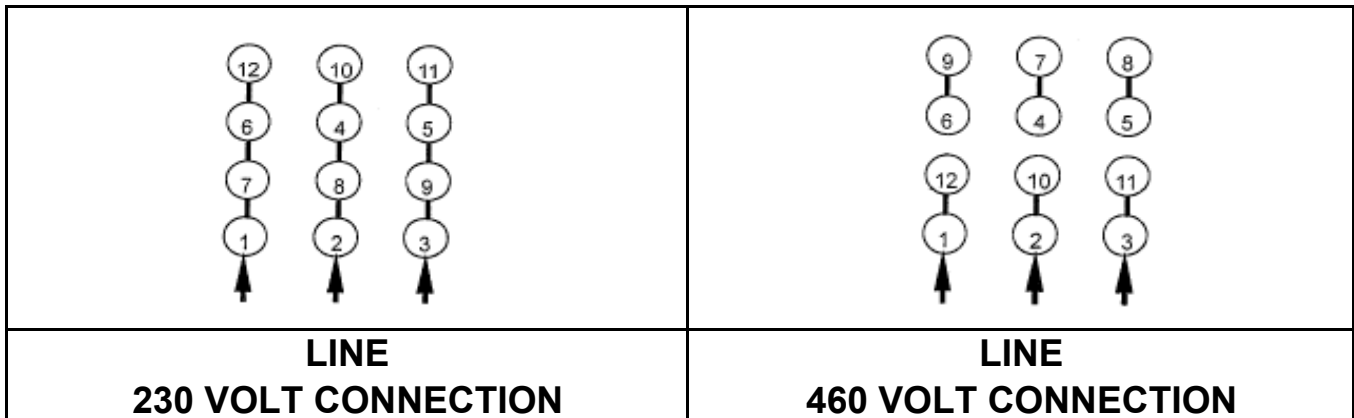

WYE START-DELTA RUN CONNECTION

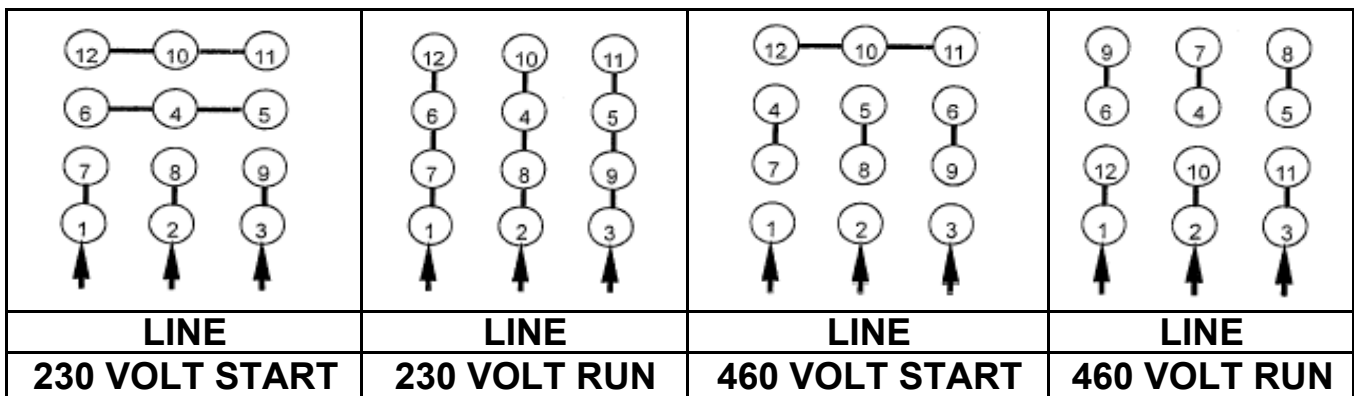

DWG NO.
DAC-1565-4