

TYPE	OUTPUT		POLE	TIME RATING	VOLTAGE	Hz	SYNSPEED R.P.M.
	HP.	KW.					
AEH8N	125	93.3	6	CONT.	230/460	60	1200

TOTALLY ENCLOSED FAN-COOLED TYPE, SQUIRREL-CAGE ROTOR

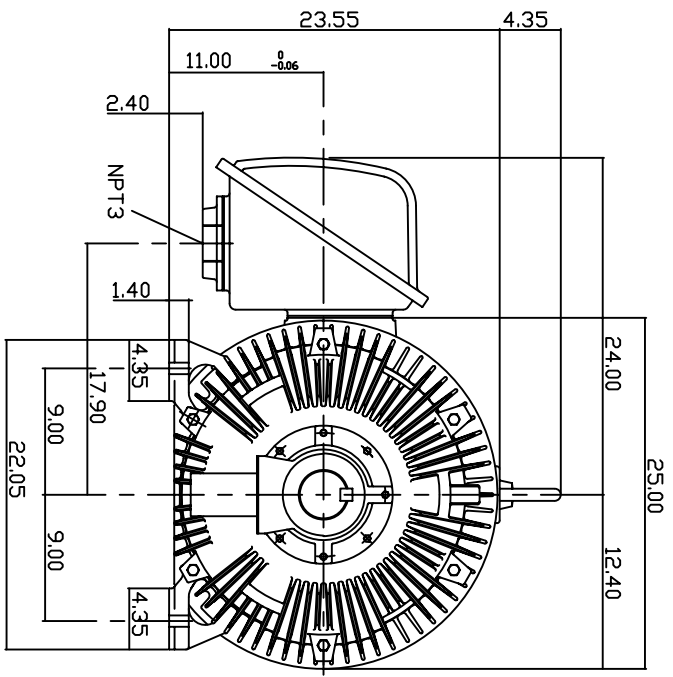
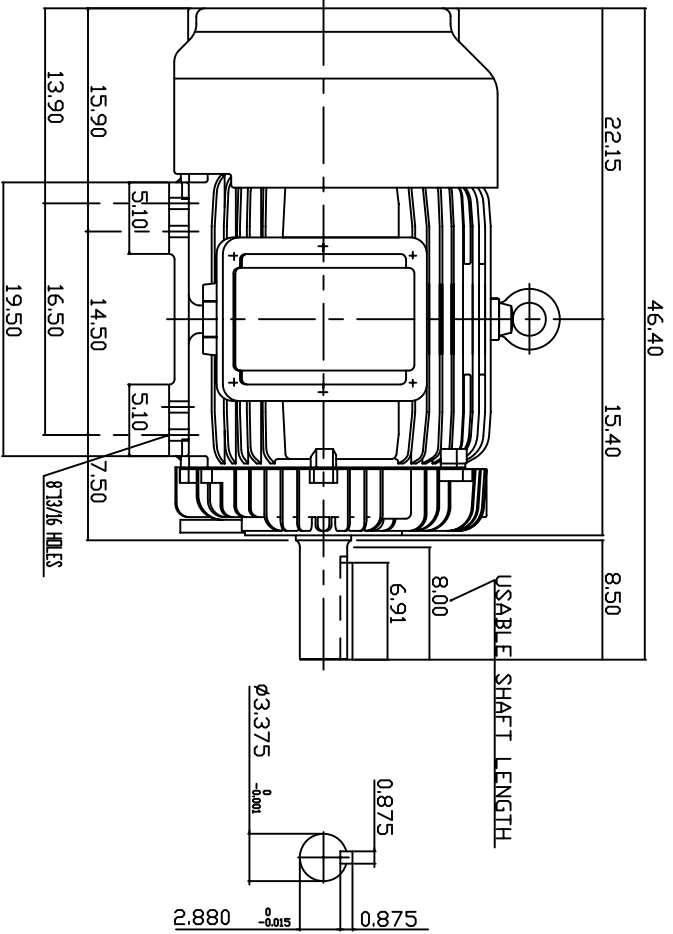

NOTE:

1. DIMENSIONS IN INCH
2. FRAME NO. 445T
3. F CLASS INSULATION, S.F.115
4. FOR BELTED SERVICE
5. ENCLOSURE: IP54
6. BEARING SIZE: DRIVE END: NU318
NON-DRIVE END: 6316
7. APPROX. WEIGHT: 1900 LBS

TW-56C

DWN. S. DING	JAN -28 -2005
CHKD. H.HUANG	JAN -28 -2005
APPD. C.WANG	JAN -28 -2005

DATE 20050616
 CATALOG # EP1256R
 OUTLINE DIMENSIONS
 3-PHASE INDUCTION MOTOR
 Dwg NO. 3A040Y651
 REV: 00

TECO Westinghouse

ISSUED 8/15/2014	PERFORMANCE DATA 3-PHASE INDUCTION MOTOR	ENCLOSURE TEFC
TYPE AEHH8N		CATALOG# EP1256R

NAMEPLATE INFORMATION

OUTPUT		POLE	FRAME SIZE	VOLTAGE	HZ	RATED AMBIENT	INS. CLASS	NEMA DESIGN	TIME RATING	SERVICE FACTOR
HP	KW									
125	93.3	6	445T	230/460	60	40°C	F	B	CONT.	1.15

VARIABLE FREQUENCY DRIVE SERVICE

VARIABLE TORQUE				OHMS/PHASE EQUIVALENT WYE CIRCUIT (AT RATED OPERATING TEMPERATURE 25°C)				
HZ	HP	RPM	TORQUE (lb-ft)	R1	R2	X1	X2	X _m
3~60	0.0156~125	60~1200	1.37~554	0.0515	0.0364	0.352	0.775	12.8

CONSTANT TORQUE				CONSTANT HORSEPOWER			
HZ	HP	RPM	TORQUE (lb-ft)	HZ	HP	RPM	TORQUE (lb-ft)
6~60	12.5~125	120~1200	554	60~90	125	1200-1800	554-369.33

TYPICAL PERFORMANCE

FULL LOAD RPM	EFFICIENCY				POWER FACTOR			SOUND PRESSURE LEVEL @ 3 FT Db(A)
	FULL LOAD		3/4 LOAD %	1/2 LOAD %	FULL LOAD %	3/4 LOAD %	1/2 LOAD %	
	MIN.%	NOM.%						
1185	94.1	95	94.5	93.6	83	80.5	74	77

CURRENTS									NEMA KVA CODE LETTER	SAFE STALL TIME IN SECONDS	
NO LOAD			FULL LOAD			LOCKED ROTOR				COLD	HOT
AT 208 VOLT	AT 230 VOLT	AT 460 VOLT	AT 208 VOLT	AT 230 VOLT	AT 460 VOLT	AT 208 VOLT	AT 230 VOLT	AT 460 VOLT			
102.00	119.40	59.7	327.31	296.00	148.00	1641.4	1815.0	910	G	17	12

TORQUE				INERTIA			ACCEL TIME (DOL)		ALLOWABLE STARTS PER HOUR	
FULL LOAD (lb-ft)	LOCKED ROTOR %FLT	PULL UP %FLT	BREAK DOWN %FLT	ROTOR WR ² (lb-ft ²)	NEMA LOAD WK ² (lb-ft ²)	MAX ALLOWABLE WK ² (lb-ft ²)	NEMA LOAD WK ² Sec	MAX ALLOWABLE WK ² Sec	COLD	HOT
555.30	140	110	230	68	1452	3630	5.91	14.37	2	1

APPROVED:	M. PRATER	DRAWING NO.	31057EP1256	REVISION:	1
-----------	------------------	-------------	--------------------	-----------	----------

DATE:
December 2, 2005

CONNECTION DIAGRAM

CATALOG NO.:
EP1256R

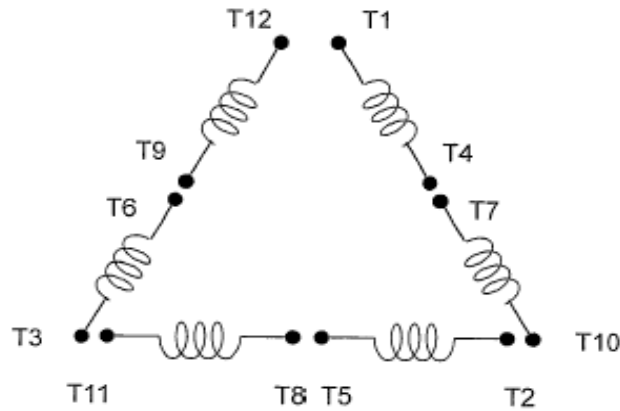

SCHEMATIC - Δ / Y CONNECTION

ACROSS THE LINE CONNECTION

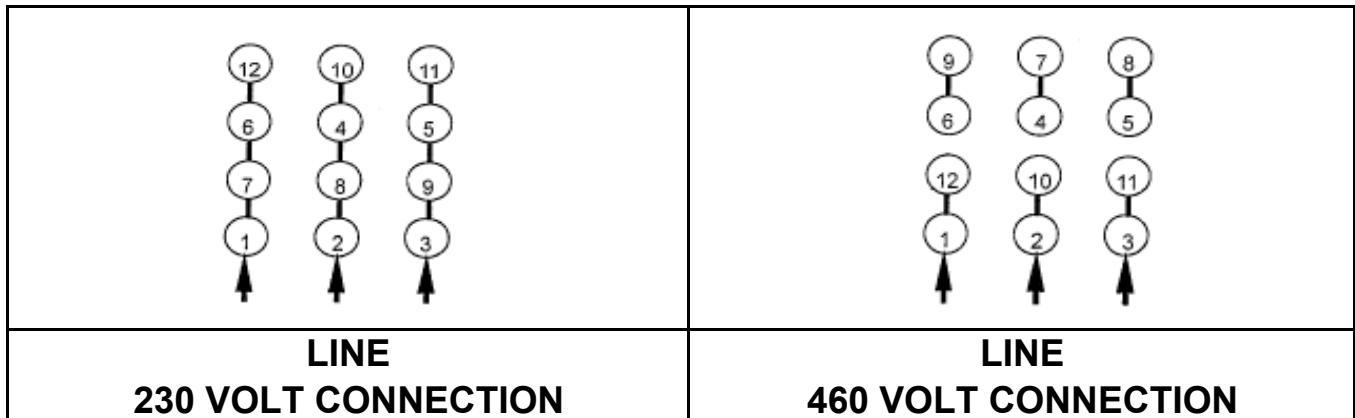

WYE START-DELTA RUN CONNECTION



DWG NO.
DAC-1565-4