

TYPE	OUTPUT HP.	KW.	POLE	RATING CNT.	VOLTAGE V	Hz	SYNSPEED R.P.M
AEH8N	150	111.9	6		460	60	1200

TOTALLY ENCLOSED FAN-COOLED TYPE, SQUIRREL-CAGE ROTOR

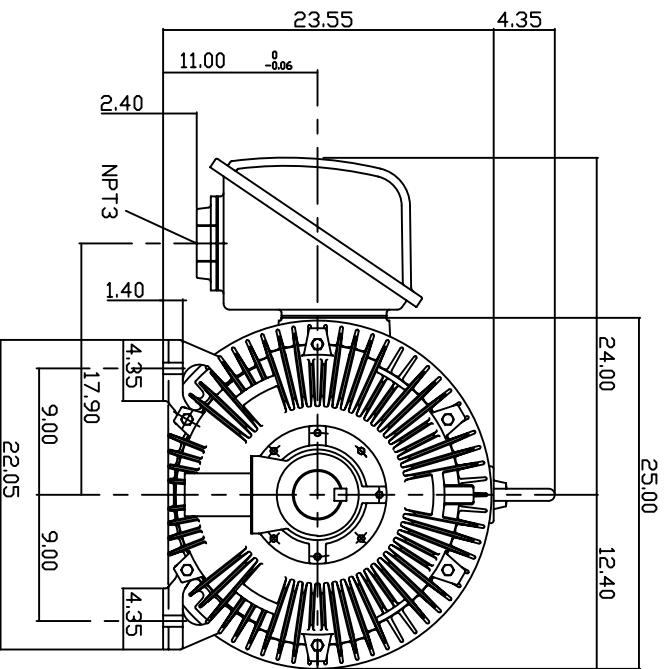
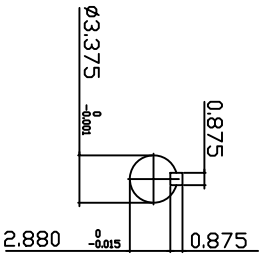
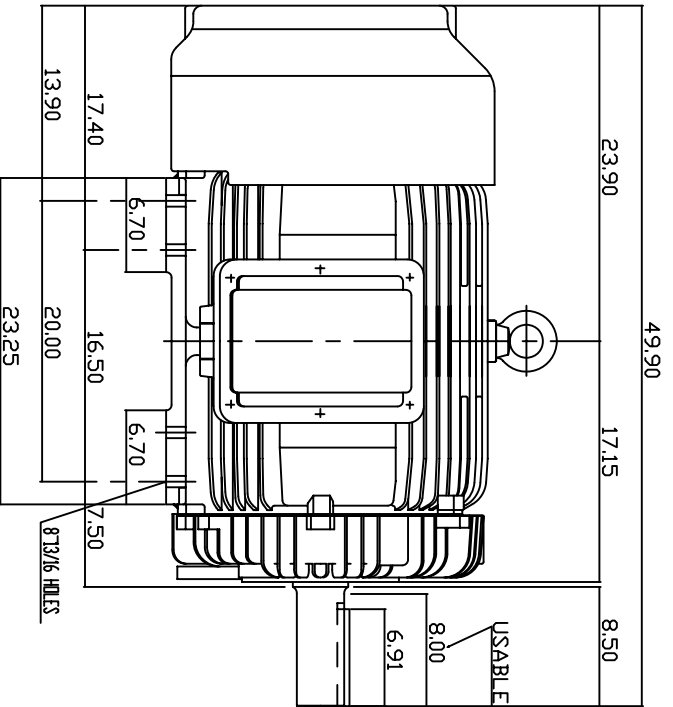

NOTE:

1. DIMENSIONS IN INCH
2. FRAME NO. 447T
3. F CLASS INSULATION, S.F.115
4. FOR BELTED SERVICE
5. ENCLOSURE: IP54
6. BEARING SIZE: DRIVE END: NU320
NON-DRIVE END: 6316
7. APPROX. WEIGHT: 2450 LBS

TW-56C

DWN. N.QIN	JAN 13 2005
CHKD. H.HUANG	JAN 13 2005
APPD. C.WANG	JAN 13 2005

DATE 20050617
CATALOG # EP1506R

OUTLINE DIMENSIONS
3-PHASE INDUCTION MOTOR



DWG NO. 3A040Y597
REV. 00

TECO Westinghouse

ISSUED 8/15/2014	PERFORMANCE DATA 3-PHASE INDUCTION MOTOR	ENCLOSURE TEFC
TYPE AEHH8N		CATALOG# EP1506R

NAMEPLATE INFORMATION

OUTPUT		POLE	FRAME SIZE	VOLTAGE	HZ	RATED AMBIENT	INS. CLASS	NEMA DESIGN	TIME RATING	SERVICE FACTOR
HP	KW									
150	111.9	6	447T	460	60	40°C	F	B	CONT.	1.15

VARIABLE FREQUENCY DRIVE SERVICE

VARIABLE TORQUE				OHMS/PHASE EQUIVALENT WYE CIRCUIT (AT RATED OPERATING TEMPERATURE 25°C)				
HZ	HP	RPM	TORQUE (lb-ft)	R1	R2	X1	X2	X _m
3~60	0.0188~150	60~1200	1.644~664	0.0445	0.0319	0.3154	0.7081	13

CONSTANT TORQUE				CONSTANT HORSEPOWER			
HZ	HP	RPM	TORQUE (lb-ft)	HZ	HP	RPM	TORQUE (lb-ft)
6~60	15~150	120~1200	664	60~90	150	1200~1800	664~442.66

TYPICAL PERFORMANCE

FULL LOAD RPM	EFFICIENCY				POWER FACTOR			SOUND PRESSURE LEVEL @ 3 FT Db(A)
	FULL LOAD		3/4 LOAD %	1/2 LOAD %	FULL LOAD %	3/4 LOAD %	1/2 LOAD %	
	MIN.%	NOM.%						
1186	95	95.8	95.4	94.5	83.5	81	74	79

CURRENTS			NEMA KVA CODE LETTER	SAFE STALL TIME IN SECONDS	
NO LOAD	FULL LOAD	LOCKED ROTOR		COLD	HOT
AT 460 VOLT	AT 460 VOLT	AT 460 VOLT			
50.4	176.00	1085	G	19	13

TORQUE				INERTIA			ACCEL TIME (DOL)		ALLOWABLE STARTS PER HOUR	
FULL LOAD (lb-ft)	LOCKED ROTOR %FLT	PULL UP %FLT	BREAK DOWN %FLT	ROTOR WR ² (lb-ft ²)	NEMA LOAD WK ² (lb-ft ²)	MAX ALLOWABLE WK ² (lb-ft ²)	NEMA LOAD WK ² Sec	MAX ALLOWABLE WK ² Sec	COLD	HOT
664.00	135	105	220	103	1719	4298	6.16	14.87	2	1

APPROVED:	M. PRATER	DRAWING NO.	31057EP1506	REVISION:	1
-----------	------------------	-------------	--------------------	-----------	----------

DATE:
December 2, 2005

CONNECTION DIAGRAM

CATALOG NO.:
EP1506R



SCHEMATIC - Δ / Y CONNECTION

ACROSS THE LINE CONNECTION



460 VOLT CONNECTION

WYE START-DELTA RUN CONNECTION



**LINE
460 VOLT START**

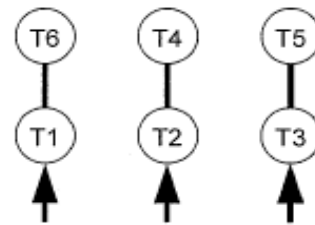

**LINE
460 VOLT RUN**