

TYPE	OUTPUT		POLE	TIME RATING	VOLTAGE V	Hz	SYN.SPEED R.P.M
	HP.	kW.					
AEHH8N	250	186.5	4	CONT.	460	60	1800

TOTALLY ENCLOSED FAN-COOLED TYPE, SQUIRREL-CAGE ROTOR

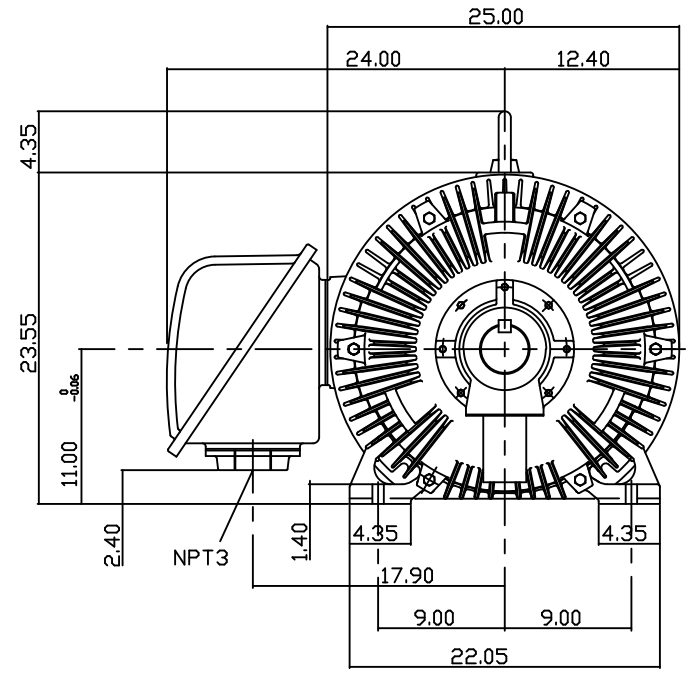
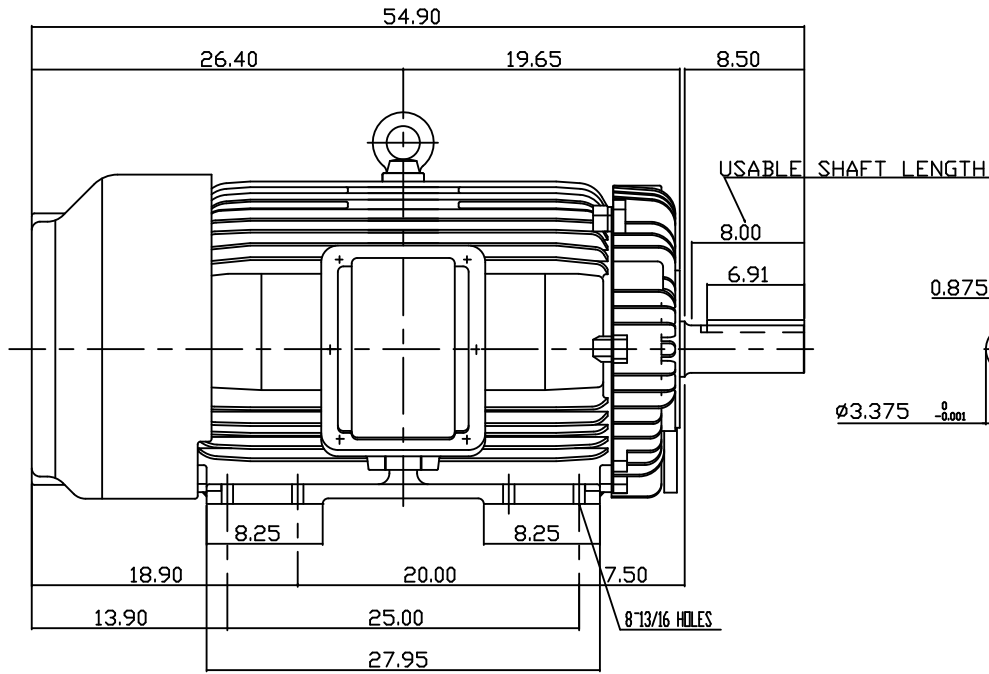

NOTE:

1. DIMENSIONS IN INCH
2. FRAME NO. 449T
3. F CLASS INSULATION, S.F.1.15
4. FOR BELTED SERVICE
5. ENCLOSURE: IP54
6. BEARING SIZE: DRIVE END: NU320
NON-DRIVE END: 6316
7. APPROX. WEIGHT: 2400 LBS

DATE 20050616

OUTLINE DIMENSIONS

CATALOG #EP2504R

3-PHASE INDUCTION MOTOR

DWN.	J.WANG	JAN 28 2005
CHKD.	H.HUANG	JAN 28 2005
APPD.	C.WANG	JAN 28 2005

TEC Westinghouse

DWG NO. 3A040Y647
REV: 00

TW-56C

TECO Westinghouse

ISSUED 8/15/2014	PERFORMANCE DATA 3-PHASE INDUCTION MOTOR	ENCLOSURE TEFC
TYPE AEHH8N		CATALOG# EP2504R

NAMEPLATE INFORMATION

OUTPUT		POLE	FRAME SIZE	VOLTAGE	HZ	RATED AMBIENT	INS. CLASS	NEMA DESIGN	TIME RATING	SERVICE FACTOR
HP	KW									
250	186.5	4	449T	460	60	40°C	F	B	CONT.	1.15

VARIABLE FREQUENCY DRIVE SERVICE

VARIABLE TORQUE				OHMS/PHASE EQUIVALENT WYE CIRCUIT (AT RATED OPERATING TEMPERATURE 25°C)				
HZ	HP	RPM	TORQUE (lb-ft)	R1	R2	X1	X2	X _m
3~60	0.0313~250	90~1800	1.826~734	0.0179	0.018	0.76	0.3753	9.6

CONSTANT TORQUE				CONSTANT HORSEPOWER			
HZ	HP	RPM	TORQUE (lb-ft)	HZ	HP	RPM	TORQUE (lb-ft)
6~60	25~250	180~1800	734	60~90	250	1800~2700	734~489.33

TYPICAL PERFORMANCE

FULL LOAD RPM	EFFICIENCY				POWER FACTOR			SOUND PRESSURE LEVEL @ 3 FT Db(A)
	FULL LOAD		3/4 LOAD %	1/2 LOAD %	FULL LOAD %	3/4 LOAD %	1/2 LOAD %	
	MIN.%	NOM.%						
1787	95.4	96.2	95.8	95	88	84.5	80	81

CURRENTS				NEMA KVA CODE LETTER	SAFE STALL TIME IN SECONDS			
NO LOAD		FULL LOAD			LOCKED ROTOR			
AT 460 VOLT		AT 460 VOLT			AT 460 VOLT			
53.8		277.00		1825		G	19	13

TORQUE				INERTIA			ACCEL TIME (DOL)		ALLOWABLE STARTS PER HOUR	
FULL LOAD (lb-ft)	LOCKED ROTOR %FLT	PULL UP %FLT	BREAK DOWN %FLT	ROTOR WR ² (lb-ft ²)	NEMA LOAD WK ² (lb-ft ²)	MAX ALLOWABLE WK ² (lb-ft ²)	NEMA LOAD WK ² Sec	MAX ALLOWABLE WK ² Sec	COLD	HOT
734.00	110	90	210	83	1017	2034	5.49	10.57	2	1

APPROVED:	M. PRATER	DRAWING NO.	31057EP2504	REVISION:	1
-----------	------------------	-------------	--------------------	-----------	----------

DATE:
December 2, 2005

CONNECTION DIAGRAM

CATALOG NO.:
EP2504R



SCHEMATIC - Δ / Y CONNECTION

ACROSS THE LINE CONNECTION



460 VOLT CONNECTION

WYE START-DELTA RUN CONNECTION



**LINE
460 VOLT START**



**LINE
460 VOLT RUN**