

TYPE	OUTPUT		POLE	TIME RATING	VOLTAGE V	Hz	SYN. SPEED R. P. M
	HP.	kW.					
AFHH			8	CONT.			

TOTALLY ENCLOSED FAN-COOLED TYPE. SQUIRREL-CAGE ROTOR

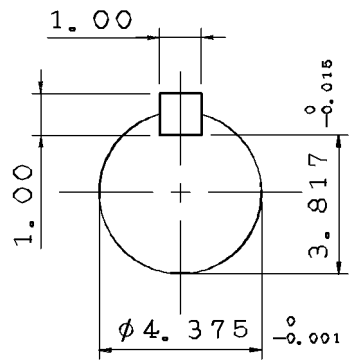

SHAFT END  
(ENLARGED VIEW)

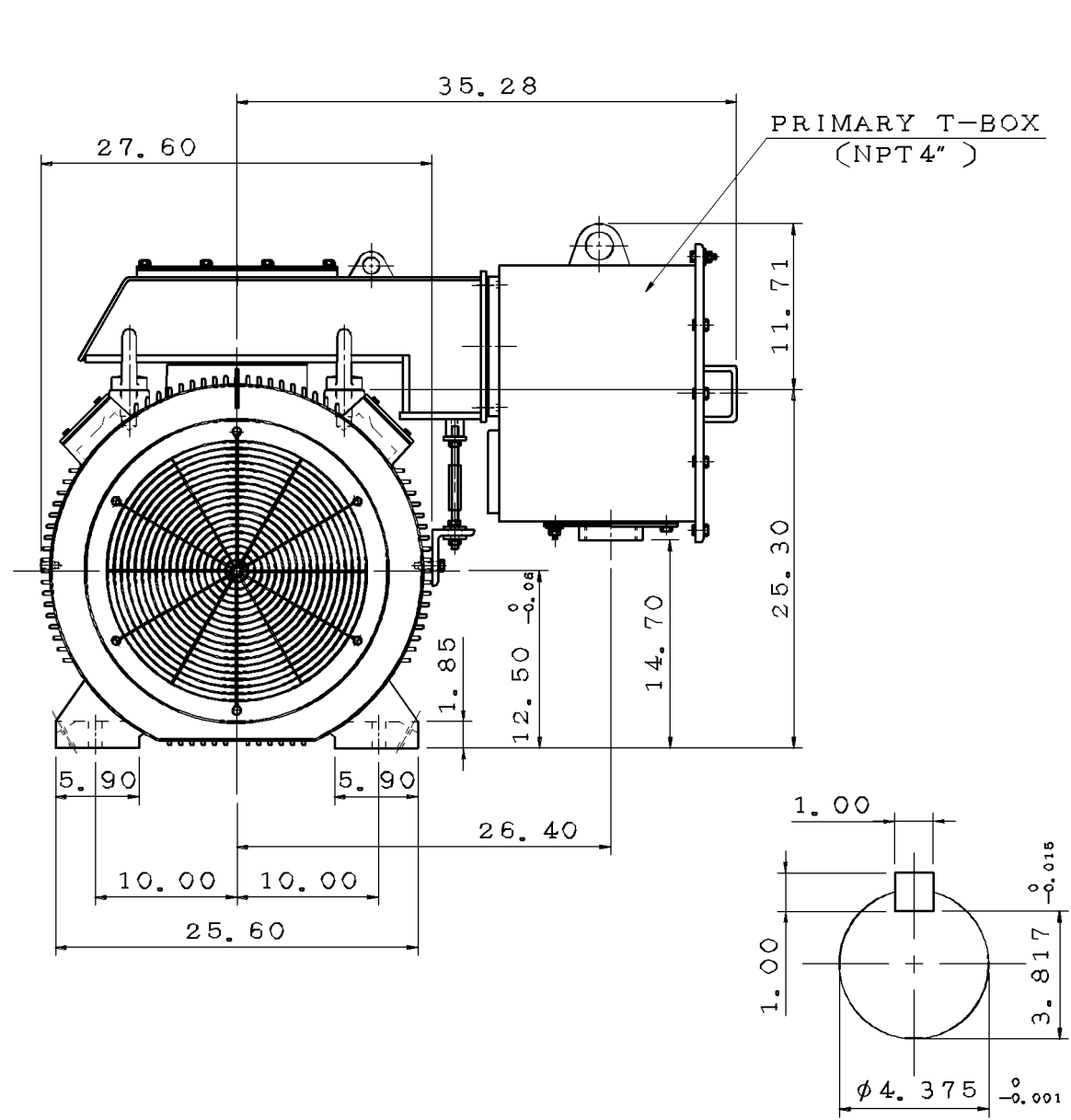
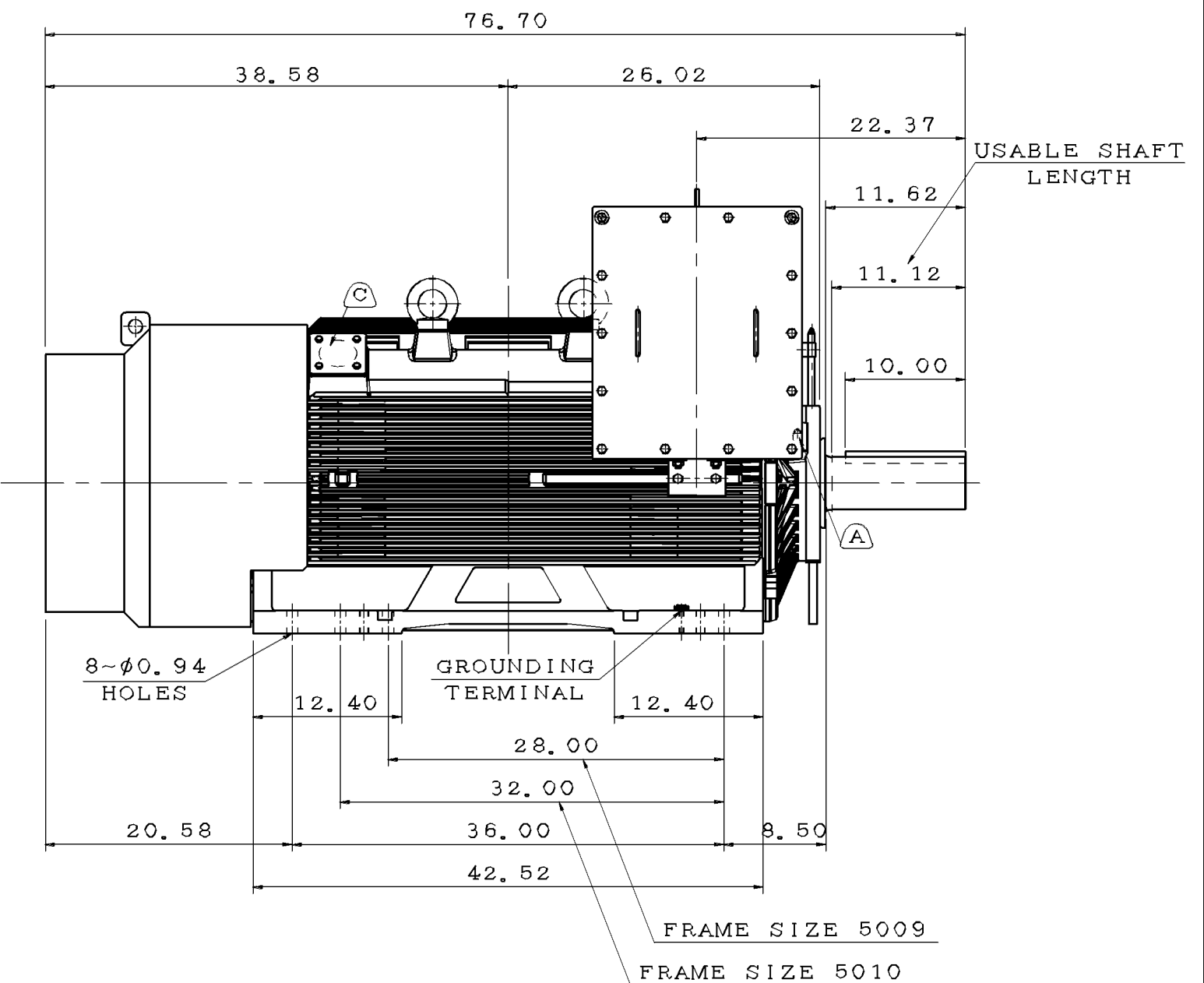

- NOTE:
1. DIMENSIONS IN inch
  2. FRAME NO. 5011C
  3. F CLASS INSULATION
  4. FOR BELT DRIVE
  5. ENCLOSURE: IP55
  6. BEARING SIZE: DRIVE-END NU324C3  
OPP. DRIVE-END 6320C3
  7. MOTOR APPROX. WEIGHT: 5120 lb

(B) FOR BEARING RTD, END BRACKETS SHALL BE PRE-DRILLED AND PLUGGED.  
(C) FOR AUXILIARY, FRAME SHALL BE PRE-DRILLED AND COVERD WITH STEEL PLATE.

DWN.	L. JHENG	APR. 22. 2019
CHKD.	H. WANG	APR. 23. 2019
APPD.	C. WANG	APR. 23. 2019

DATE	OUTLINE DIMENSIONS
	3-PHASE INDUCTION MOTOR

<b>TECO</b> Westinghouse	DWG NO.	REV:01
	5A040C173	



TEFC, 8P 460V 60HZ

OUTPUT HP	FULL LOAD RPM	FRAME NO. (EG)	EFFICIENCY			POWER FACTOR			CURRENT			TORQUE		Safe Stall Time(s)		ROTOR WR <sup>2</sup> LB-FT <sup>2</sup>	Max. Load WR <sup>2</sup> LB-FT <sup>2</sup>	APPROX. WEIGHT LBS
			FULL LOAD	3/4 LOAD	1/2 LOAD	FULL LOAD	3/4 LOAD	1/2 LOAD	Rated A	Starting %	Starting A	Starting %	Max. %	HOT SEC	COLD SEC			
			%	%	%	%	%	%	%	%	%	%	%					
200	890	5009B	94.5	94.2	93.6	79.4	76.2	66.9	250	581	1450	95	200	15	23	153	8099	3700
250	890	5009B	95.0	94.6	94.1	79.9	76.3	66.8	309	592	1825	100	200	14	22	186	9953	3900
300	889	5009B	95.0	94.8	94.4	81.1	78.4	70.1	365	603	2200	100	200	14	21	224	11743	4100
350	889	5009B	95.0	94.8	94.5	81.2	78.5	70.2	425	600	2550	100	200	13	21	258	13512	4300
400	890	5011B	95.1	94.9	94.6	80.9	77.5	68.5	487	596	2900	100	200	12	18	301	15260	4900
450	890	5011B	95.1	94.9	94.6	80.6	76.9	67.6	550	591	3250	100	210	13	20	339	16986	5100
500	890	5810B※	95.2	95.0	94.8	82.6	79.7	71.5	595	609	3625	95	200	15	23	437	18670	6600
600	891	5810B※	95.5	95.3	95.0	81.2	77.8	68.5	725	653	4730	95	200	22	29	445	21995	6700
700	891	5810B※	95.6	95.4	95.1	81.5	78.1	68.9	841	654	5500	95	200	23	28	517	25255	7200
800	893	6808B※	95.6	95.4	95.0	81.7	78.3	69.6	959	657	6300	100	200	24	31	1391	28431	8800
900	893	6808B※*	95.8	95.4	95.0	82.5	79.6	71.6	1066	666	7100	100	200	24	30	1514	31543	9200

NOTE: 1 ACCORDING TO NEMA MG-1  
 8P: RATINGS 250HP AND BELOW ARE PREMIUM EFFICIENCY.  
 2 WITH "※" : COPPER ROTOR  
 3 WITHOUT "※" : ALUMINUM ROTOR  
 4 MULTIPLE MOUNTING DIMENSIONS FOR EACH FRAME NO.  
 FRAME 5009: MOUNTING HOLE WITH 5009 & 5007  
 FRAME 5011: MOUNTING HOLE WITH 5011, 5010 & 5009  
 5 WITH "\*" : NO CSA CERTIFICATION. (8P 900HP)

DATE:  
April 8, 2020

# CONNECTION DIAGRAM

SERIES:  
AFHH

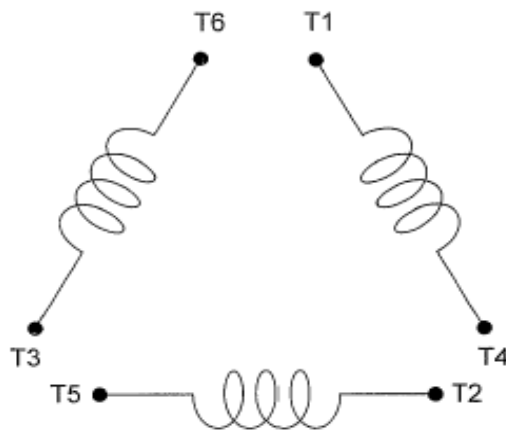

**SCHEMATIC - Δ CONNECTION**

## ACROSS THE LINE CONNECTION

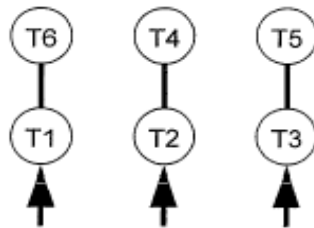

**460 VOLT CONNECTION**

## WYE START-DELTA RUN CONNECTION

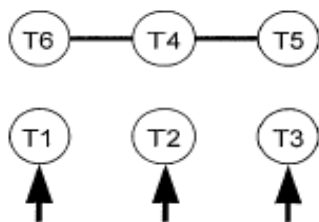

**LINE  
460 VOLT START**

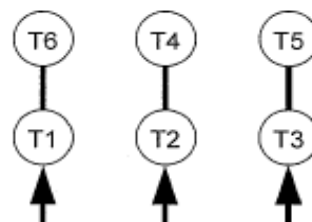

**LINE  
460 VOLT RUN**