

TYPE	OUTPUT		POLE	TIME RATING	VOLTAGE V	Hz	SYN. SPEED R. P. M
	HP.	kW.					
AFHH			4	CONT.			

TOTALLY ENCLOSED FAN-COOLED TYPE. SQUIRREL-CAGE ROTOR

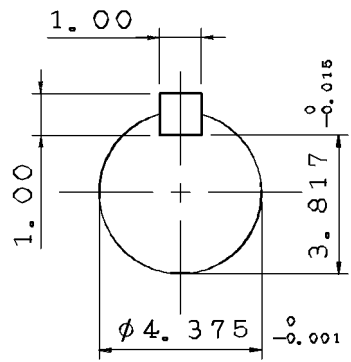

SHAFT END
(ENLARGED VIEW)

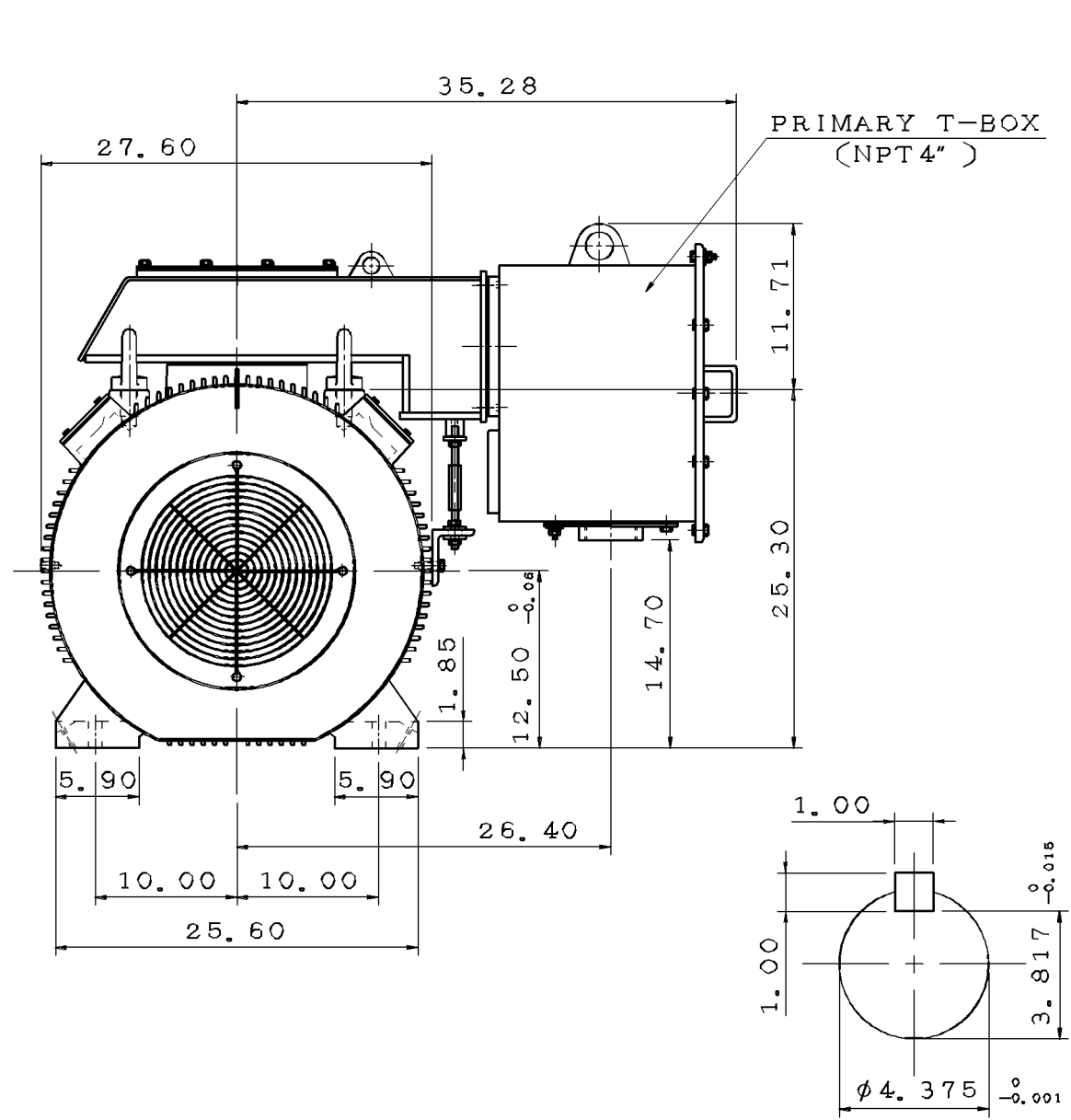
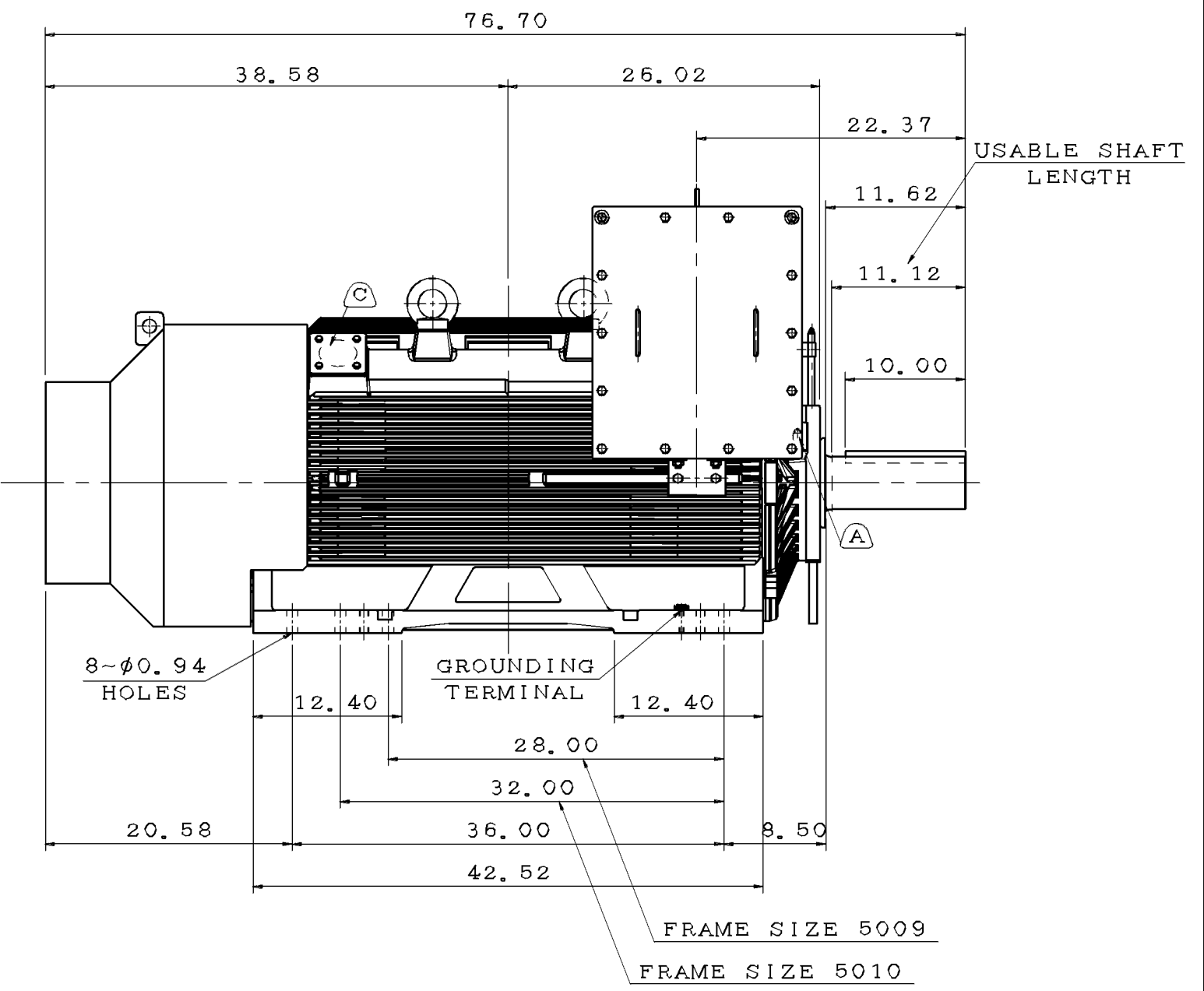

- NOTE:
1. DIMENSIONS IN inch
 2. FRAME NO. 5011C
 3. F CLASS INSULATION
 4. FOR BELT DRIVE
 5. ENCLOSURE: IP55
 6. BEARING SIZE: DRIVE-END NU324C3
OPP. DRIVE-END 6320C3
 7. MOTOR APPROX. WEIGHT: 5220 lb

(B) FOR BEARING RTD, END BRACKETS SHALL BE PRE-DRILLED AND PLUGGED.
(C) FOR AUXILIARY, FRAME SHALL BE PRE-DRILLED AND COVERD WITH STEEL PLATE.

DWN.	L. JHENG	APR. 22. 2019
CHKD.	H. WANG	APR. 23. 2019
APPD.	C. WANG	APR. 23. 2019

DATE	OUTLINE DIMENSIONS
	3-PHASE INDUCTION MOTOR

TECO Westinghouse	DWG NO.	REV:01
	5A040C168	



TEFC, 4P 460V 60HZ

OUTPUT HP	FULL LOAD RPM	FRAME NO. (EG)	EFFICIENCY			POWER FACTOR			CURRENT			TORQUE		Safe Stall Time(s)		ROTOR WR ² LB-FT ²	Max. Load WR ² LB-FT ²	APPROX. WEIGHT LBS
			FULL LOAD	3/4 LOAD	1/2 LOAD	FULL LOAD	3/4 LOAD	1/2 LOAD	Rated A	Starting %	Starting A	Starting %	Max. %	HOT SEC	COLD SEC			
			%	%	%	%	%	%										
350	1785	5009B	96.2	95.9	95.3	88.2	87.2	82.4	386	660	2550	95	200	12	18	138	1854	3700
400	1785	5009B	96.2	95.9	95.4	88.4	87.6	83.1	440	659	2900	95	210	12	19	155	2089	3900
450	1786	5009B	96.2	96.0	95.5	88.7	87.6	83.0	494	658	3250	100	210	11	18	176	2302	4100
500	1786	5011B	96.2	96.0	95.5	87.3	86.1	80.0	557	651	3625	100	210	13	20	200	2536	4500
600	1785	5011B	96.3	96.1	95.7	88.7	87.9	84.2	658	719	4730	100	210	17	22	231	2962	4800
700	1791	5011B※	96.5	96.3	95.9	87.8	86.4	81.2	774	711	5500	100	200	15	22	242	3389	5200
800	1787	5810B※	96.0	95.9	95.5	88.2	87.0	82.3	885	712	6300	95	200	11	17	356	3794	6600
900	1787	5810B※*	96.0	95.9	95.5	88.4	87.4	83.1	993	715	7100	95	200	10	15	403	4177	7000
1000	1786	5810B※*	96.0	95.9	95.5	88.1	87.6	83.8	1107	714	7900	95	200	26	31	403	4561	7000

NOTE: 1 ACCORDING TO NEMA MG-1
 4P: RATINGS 500HP AND BELOW ARE PREMIUM EFFICIENCY.
 2 WITH "※" : COPPER ROTOR
 3 WITHOUT "※" : ALUMINUM ROTOR
 4 MULTIPLE MOUNTING DIMENSIONS FOR EACH FRAME NO.
 FRAME 5009: MOUNTING HOLE WITH 5009 & 5007
 FRAME 5011: MOUNTING HOLE WITH 5011, 5010 & 5009
 5 WITH "*" : NO CSA CERTIFICATION. (4P 900, 1000HP)

DATE:
April 8, 2020

CONNECTION DIAGRAM

SERIES:
AFHH



SCHEMATIC - Δ CONNECTION

ACROSS THE LINE CONNECTION

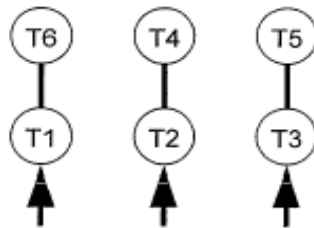

460 VOLT CONNECTION

WYE START-DELTA RUN CONNECTION

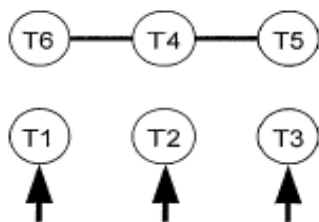

**LINE
460 VOLT START**

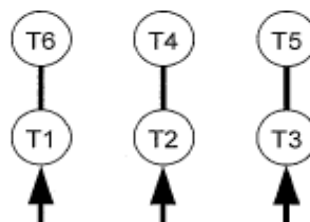

**LINE
460 VOLT RUN**