

TYPE	OUTPUT		POLE	TIME RATING	VOLTAGE V	Hz	SYN. SPEED R. P. M
	HP.	kW.					
AFHH			6	CONT.			

TOTALLY ENCLOSED FAN-COOLED TYPE. SQUIRREL-CAGE ROTOR

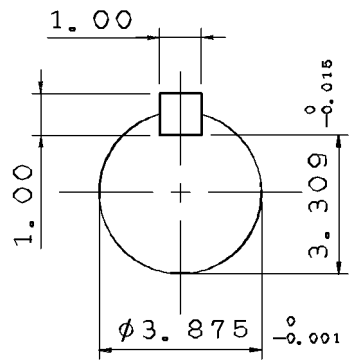

SHAFT END
(ENLARGED VIEW)

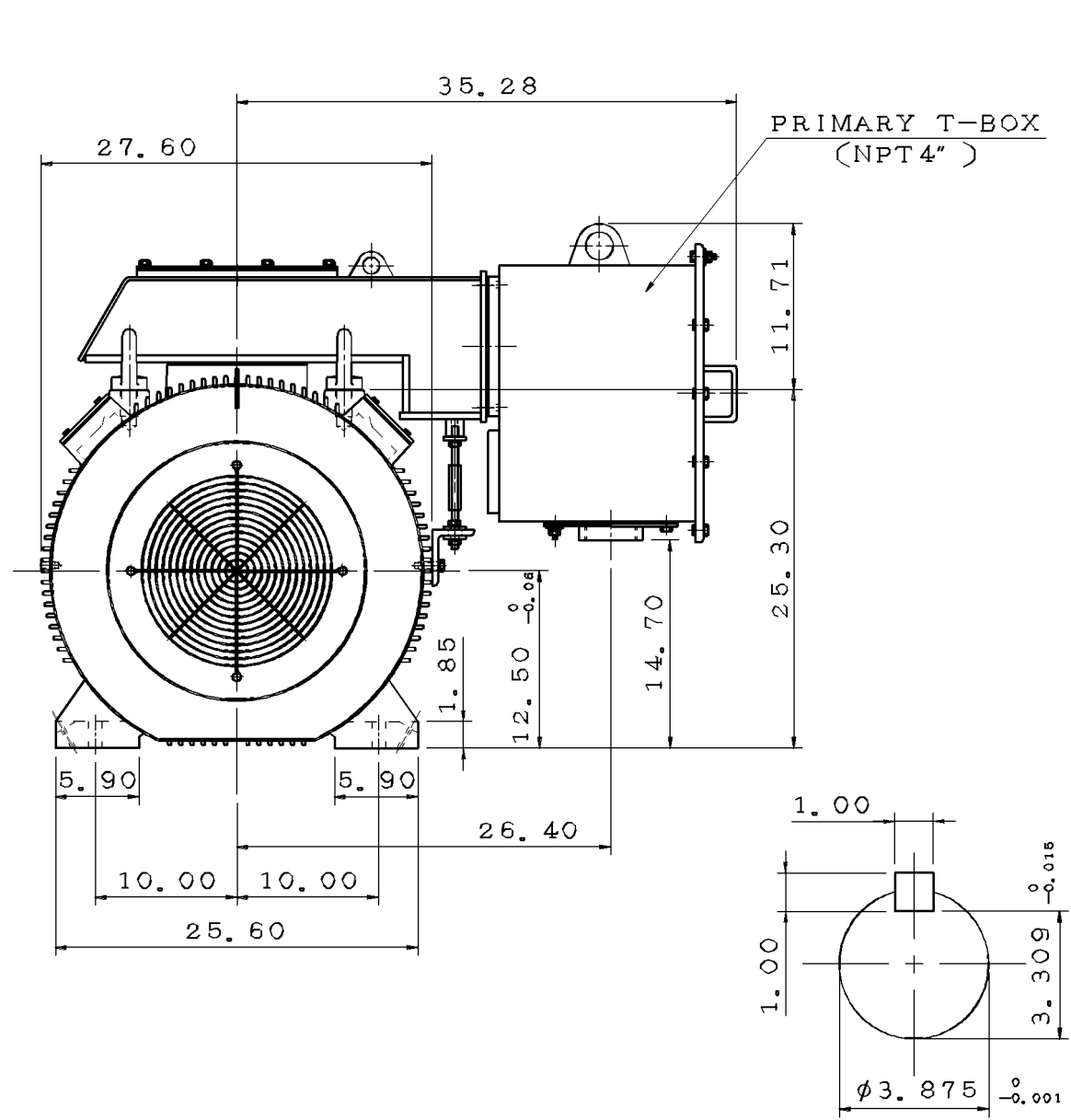
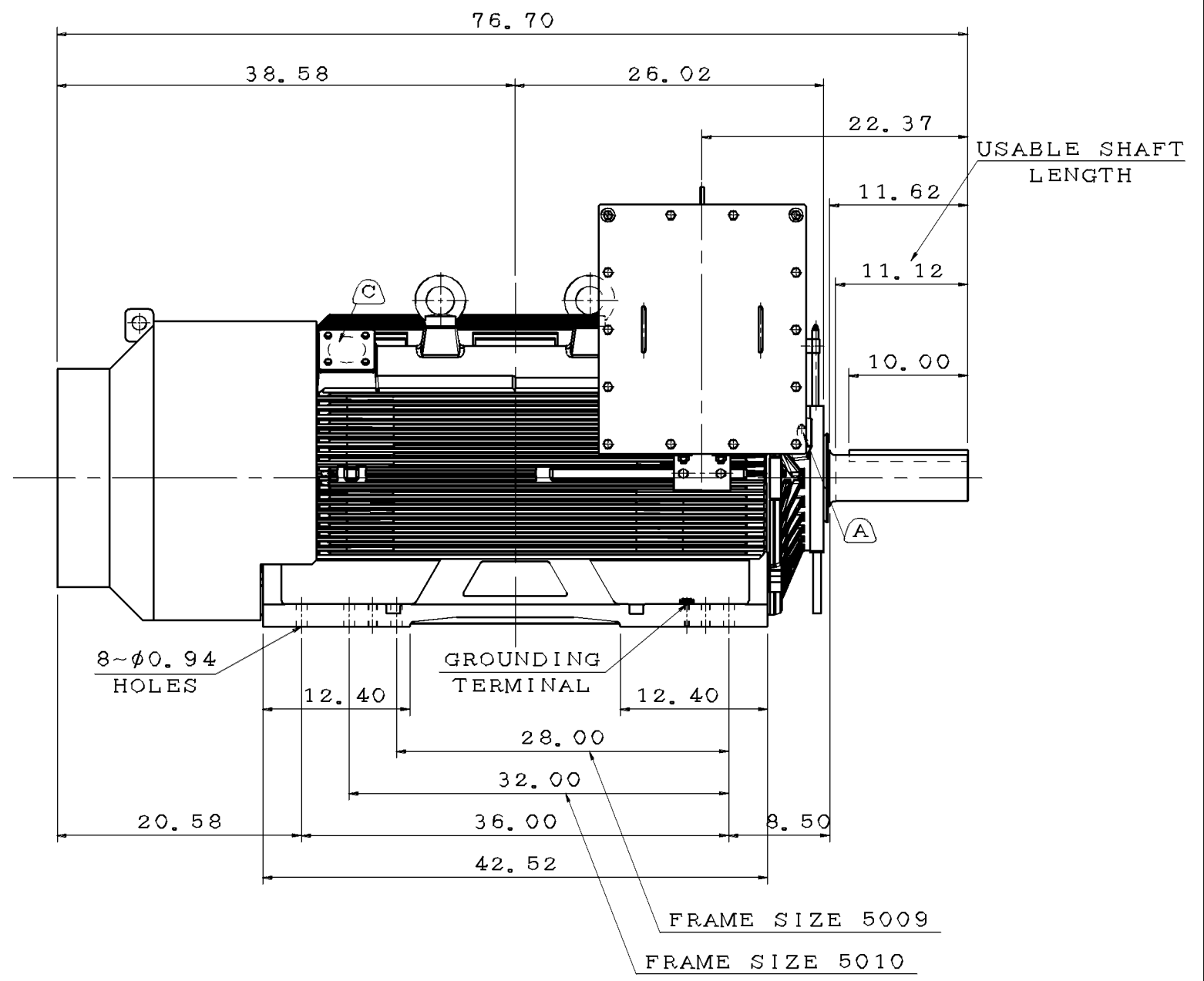

- NOTE:
1. DIMENSIONS IN inch
 2. FRAME NO. 5011B
 3. F CLASS INSULATION
 4. FOR DIRECT FLEXIBLE COUPLING
 5. ENCLOSURE: IP55
 6. BEARING SIZE: DRIVE-END 6324C3
OPP. DRIVE-END 6320C3
 7. MOTOR APPROX. WEIGHT: 5300 lb

(B) FOR BEARING RTD, END BRACKETS SHALL BE PRE-DRILLED AND PLUGGED.
(C) FOR AUXILIARY, FRAME SHALL BE PRE-DRILLED AND COVERD WITH STEEL PLATE.

DWN.	L. JHENG	APR. 22. 2019
CHKD.	H. WANG	APR. 23. 2019
APPD.	C. WANG	APR. 23. 2019

DATE	OUTLINE DIMENSIONS
	3-PHASE INDUCTION MOTOR

TECO Westinghouse	DWG NO.	REV:01
	5A040C169	



TEFC, 6P 460V 60HZ

OUTPUT HP	FULL LOAD RPM	FRAME NO. (EG)	EFFICIENCY			POWER FACTOR			CURRENT			TORQUE		Safe Stall Time(s)		ROTOR WR ² LB-FT ²	Max. Load WR ² LB-FT ²	APPROX. WEIGHT LBS
			FULL LOAD	3/4 LOAD	1/2 LOAD	FULL LOAD	3/4 LOAD	1/2 LOAD	Rated A	Starting %	Starting A	Starting %	Max. %	HOT SEC	COLD SEC			
			%	%	%	%	%	%	%	%	%	%	%					
300	1187	5009B	95.8	95.4	94.8	80.6	76.9	67.3	364	605	2200	100	200	15	19	153	5818	3900
350	1187	5009B	95.8	95.5	95.0	80.8	77.1	67.7	423	603	2550	110	200	14	18	177	6692	4100
400	1187	5011B	95.8	95.6	95.1	79.8	75.5	65.3	490	592	2900	110	200	13	17	205	7545	4600
450	1186	5011B	95.9	95.7	95.4	81.4	78.5	70.0	539	602	3250	110	200	14	18	229	8376	4800
500	1187	5011B	96.1	95.8	95.4	80.8	77.0	67.5	603	601	3625	110	200	12	16	253	9207	5000
600	1190	5011B※	96.4	96.0	95.7	84.5	82.1	74.3	689	686	4730	110	210	14	22	264	10827	5300
700	1188	5810B※	95.8	95.9	95.6	86.9	86.1	81.7	787	698	5500	95	200	17	25	385	12404	6300
800	1189	5810B※	96.0	96.0	95.7	86.9	85.7	80.4	898	702	6300	100	210	15	22	436	13938	6600
900	1189	5810B※*	96.0	96.1	95.8	87.4	86.4	81.9	1005	707	7100	100	210	16	22	516	15430	7200

NOTE: 1 ACCORDING TO NEMA MG-1
 6P: RATINGS 350HP AND BELOW ARE PREMIUM EFFICIENCY.
 2 WITH "※" : COPPER ROTOR
 3 WITHOUT "※" : ALUMINUM ROTOR
 4 MULTIPLE MOUNTING DIMENSIONS FOR EACH FRAME NO.
 FRAME 5009: MOUNTING HOLE WITH 5009 & 5007
 FRAME 5011: MOUNTING HOLE WITH 5011, 5010 & 5009
 5 WITH " * " : NO CSA CERTIFICATION. (6P 900HP)

DATE:
April 8, 2020

CONNECTION DIAGRAM

SERIES:
AFHH

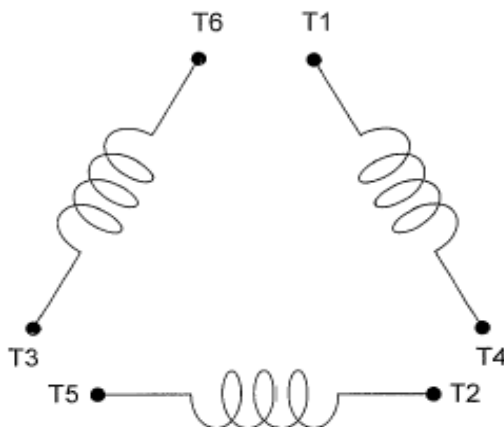

SCHEMATIC - Δ CONNECTION

ACROSS THE LINE CONNECTION

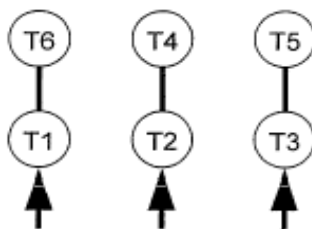

460 VOLT CONNECTION

WYE START-DELTA RUN CONNECTION

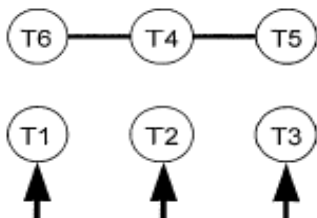

**LINE
460 VOLT START**

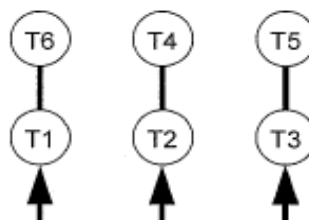

**LINE
460 VOLT RUN**