

DATE
JAN. 4, 2007
CAT. #: EPV0604C

OUTLINE DIMENSIONS
3-PHASE INDUCTION MOTOR

MOTOR TYPE:
AEUH8NDC
FRAME NO. 364TC

Pole	HP	kW	Hz	VOLT	Syn. Speed r/min(rpm)
4	60	45	60	230/460	1800

Ins	Rating	Dimension in	Approx Weight	Bearings	
F	CONT.	inches	925 LBS	DE: 6313	NDE: 6213

Totally Enclosed Fan-Cooled Type. Squirrel-Cage Rotor.

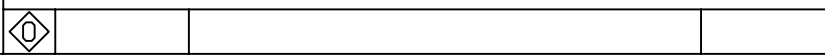
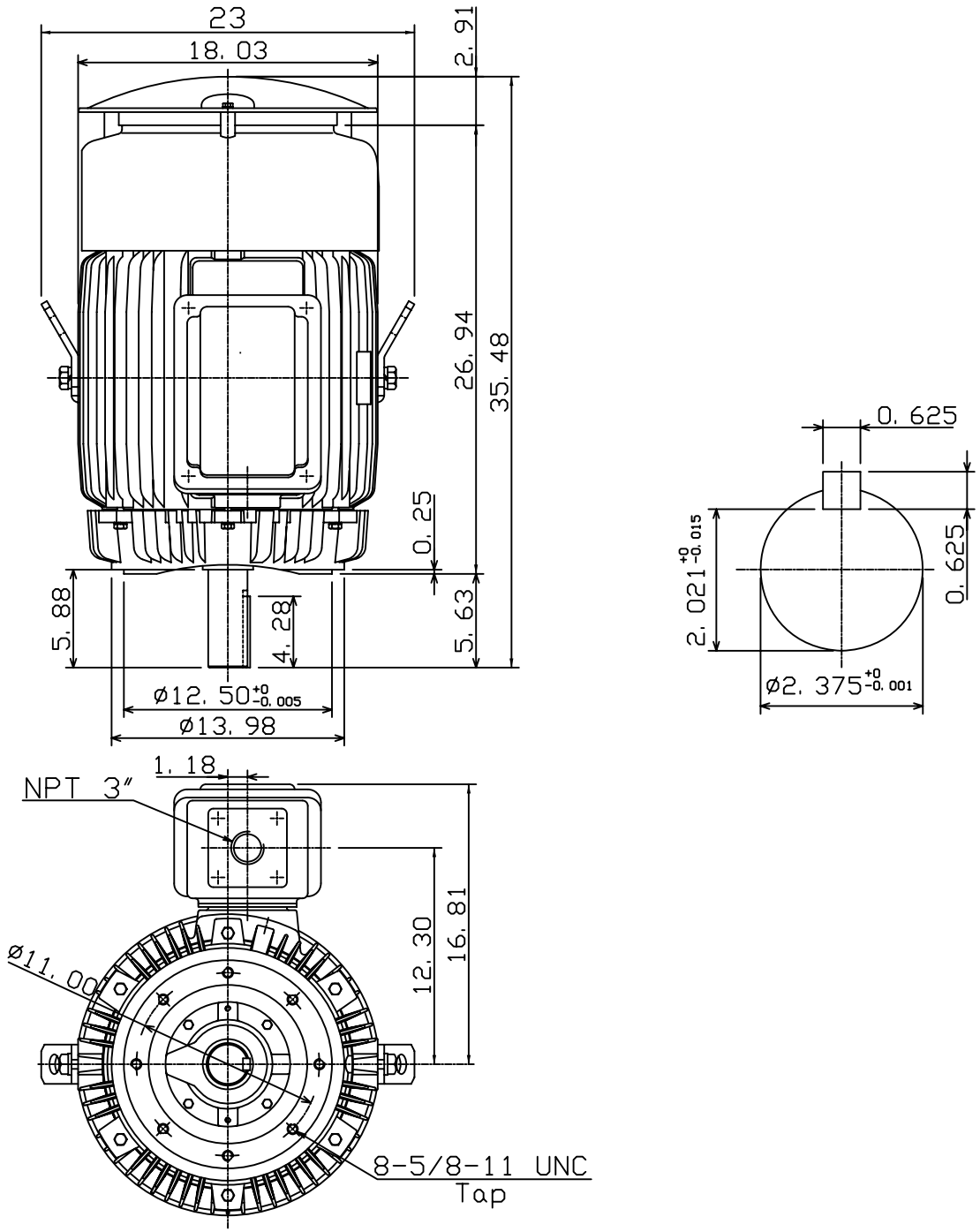

DWN.	K. L. KUO	01-02-07
CHKD.	K. L. KUO	01-02-07
APPD.	M. C. TSAI	01-02-07



DWG NO.
31057H178570

TECO Westinghouse

ISSUED 8/29/2014	PERFORMANCE DATA 3-PHASE INDUCTION MOTOR	ENCLOSURE TEFC
TYPE AEUH8NDC		CATALOG# EPV0604C

NAMEPLATE INFORMATION

OUTPUT		POLE	FRAME SIZE	VOLTAGE	HZ	RATED AMBIENT	INS. CLASS	NEMA DESIGN	TIME RATING	SERVICE FACTOR
HP	KW									
60	44.8	4	364TC	230/460	60	40°C	F	B	CONT.	1.15

VARIABLE FREQUENCY DRIVE SERVICE

VARIABLE TORQUE				OHMS/PHASE EQUIVALENT WYE CIRCUIT (AT RATED OPERATING TEMPERATURE 25°C)				
HZ	HP	RPM	TORQUE (lb-ft)	R1	R2	X1	X2	X _m
3~60	0.0075~60	90~1800	0.438~177.5	0.0404	0.0827	0.2924	0.5274	12.217

CONSTANT TORQUE				CONSTANT HORSEPOWER			
HZ	HP	RPM	TORQUE (lb-ft)	HZ	HP	RPM	TORQUE (lb-ft)
6~60	6~60	180~1800	177.5	60~90	60	1800~2700	177.5~118.3

TYPICAL PERFORMANCE

FULL LOAD RPM	EFFICIENCY				POWER FACTOR			SOUND PRESSURE LEVEL @ 3 FT Db(A)
	FULL LOAD		3/4 LOAD %	1/2 LOAD %	FULL LOAD %	3/4 LOAD %	1/2 LOAD %	
	MIN.%	NOM.%						
1775	94.1	95	95	94.5	86.5	83	75.5	79

CURRENTS									NEMA KVA CODE LETTER	SAFE STALL TIME IN SECONDS	
NO LOAD			FULL LOAD			LOCKED ROTOR				COLD	HOT
AT 208 VOLT	AT 230 VOLT	AT 460 VOLT	AT 208 VOLT	AT 230 VOLT	AT 460 VOLT	AT 208 VOLT	AT 230 VOLT	AT 460 VOLT			
32.90	42.40	21.2	151.27	136.80	68.40	786.8	870.0	435	G	17	12

TORQUE				INERTIA			ACCEL TIME (DOL)		ALLOWABLE STARTS PER HOUR	
FULL LOAD (lb-ft)	LOCKED ROTOR %FLT	PULL UP %FLT	BREAK DOWN %FLT	ROTOR WR ² (lb-ft ²)	NEMA LOAD WK ² (lb-ft ²)	MAX ALLOWABLE WK ² (lb-ft ²)	NEMA LOAD WK ² Sec	MAX ALLOWABLE WK ² Sec	COLD	HOT
177.50	200	155	240	12.229	275	583	4.59	9.50	2	1

APPROVED:	M. PRATER	DRAWING NO.	31057EPV0604C	REVISION:	1
-----------	------------------	-------------	----------------------	-----------	----------

DATE:
September 13, 2006

CONNECTION DIAGRAM

CATALOG NO.:
EPV0604C



SCHEMATIC - Δ / Y CONNECTION

ACROSS THE LINE CONNECTION



WYE START-DELTA RUN CONNECTION



DWG NO.
DAC-1565-4