

TYPE	OUTPUT		POLE	TIME RATING	VOLTAGE V	Hz	SYN. SPEED R.P.M
	HP.	kW.					
AEHHSY	250	186.5	4	CONT.	460	60	1800

TOTALLY ENCLOSED FAN-COOLED TYPE. SQUIRREL-CAGE ROTOR

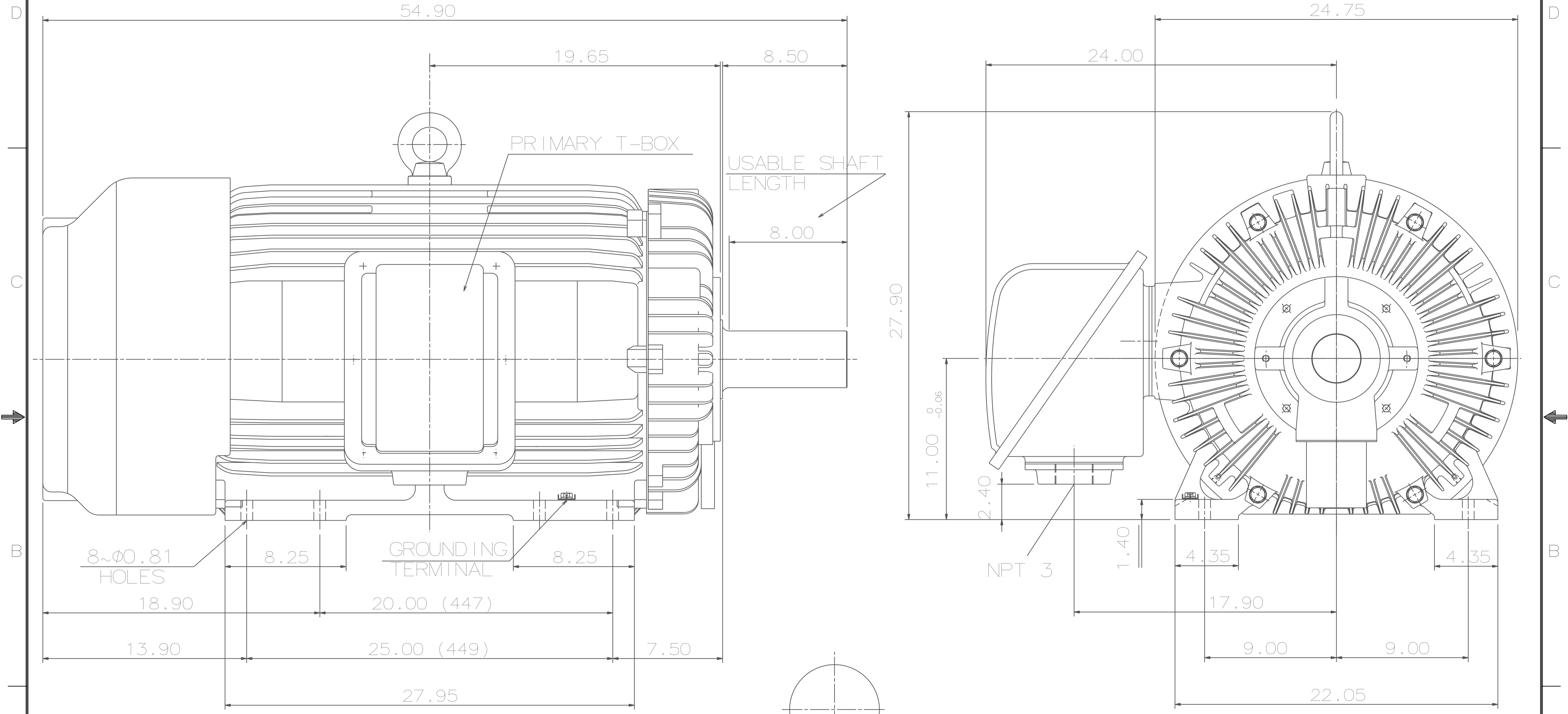

- NOTE:
1. DIMENSIONS IN INCH.
  2. FRAME NO. 449TY
  3. F CLASS INSULATION, S.F.1.15
  4. FOR DIRECT FLEXIBLE COUPLING
  5. ENCLOSURE: IP55
  6. BEARING SIZE: DRIVE-END 6224  
OPP. DRIVE-END 6316
  7. MOTOR APPROX. WEIGHT: 2520 LBS

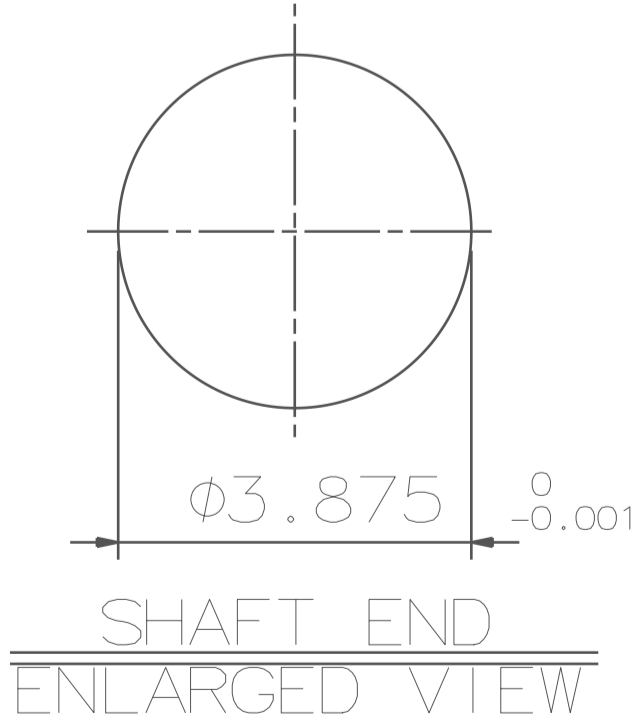

DATE	12/7/15	OUTLINE DIMENSIONS
CATALOG#	EPY2504	

DWN.	S.H.SHEN	03.07.14
CHKD.	S.H.SHEN	03.07.14
APPD.	C.H.SHYU	03.07.14

**TECO** **Westinghouse**

DWG NO. 31057C547651      REV: 00

# TECO Westinghouse

ISSUED <b>8/15/2014</b>	<b>PERFORMANCE DATA</b> <b>3-PHASE INDUCTION MOTOR</b>	ENCLOSURE <b>TEFC</b>
TYPE <b>AEHHSY</b>		CATALOG# <b>EPY2504</b>

### NAMEPLATE INFORMATION

OUTPUT		POLE	FRAME SIZE	VOLTAGE	HZ	RATED AMBIENT	INS. CLASS	NEMA DESIGN	TIME RATING	SERVICE FACTOR
HP	KW									
<b>250</b>	<b>186.5</b>	<b>4</b>	<b>449TY</b>	<b>460</b>	<b>60</b>	<b>40°C</b>	<b>F</b>	<b>B</b>	<b>CONT.</b>	<b>1.15</b>

### VARIABLE FREQUENCY DRIVE SERVICE

VARIABLE TORQUE				OHMS/PHASE EQUIVALENT WYE CIRCUIT (AT RATED OPERATING TEMPERATURE 25°C)				
HZ	HP	RPM	TORQUE (lb-ft)	R1	R2	X1	X2	X <sub>m</sub>
<b>3~60</b>	<b>0.0313~250</b>	<b>90~1800</b>	<b>1.826~734</b>	<b>0.0179</b>	<b>0.018</b>	<b>0.76</b>	<b>0.3753</b>	<b>9.6</b>

CONSTANT TORQUE				CONSTANT HORSEPOWER			
HZ	HP	RPM	TORQUE (lb-ft)	HZ	HP	RPM	TORQUE (lb-ft)
<b>6~60</b>	<b>25~250</b>	<b>180~1800</b>	<b>734</b>	<b>60~90</b>	<b>250</b>	<b>1800~2700</b>	<b>734~489.33</b>

### TYPICAL PERFORMANCE

FULL LOAD RPM	EFFICIENCY				POWER FACTOR			SOUND PRESSURE LEVEL @ 3 FT Db(A)
	FULL LOAD		3/4 LOAD %	1/2 LOAD %	FULL LOAD %	3/4 LOAD %	1/2 LOAD %	
	MIN.%	NOM.%						
<b>1787</b>	<b>95.4</b>	<b>96.2</b>	<b>95.8</b>	<b>95</b>	<b>88</b>	<b>84.5</b>	<b>80</b>	<b>81</b>

CURRENTS			NEMA KVA CODE LETTER	SAFE STALL TIME IN SECONDS	
NO LOAD	FULL LOAD	LOCKED ROTOR		COLD	HOT
AT 460 VOLT	AT 460 VOLT	AT 460 VOLT			
<b>53.8</b>	<b>277.00</b>	<b>1825</b>	<b>G</b>	<b>19</b>	<b>13</b>

TORQUE				INERTIA			ACCEL TIME (DOL)		ALLOWABLE STARTS PER HOUR	
FULL LOAD (lb-ft)	LOCKED ROTOR %FLT	PULL UP %FLT	BREAK DOWN %FLT	ROTOR WR <sup>2</sup> (lb-ft <sup>2</sup> )	NEMA LOAD WK <sup>2</sup> (lb-ft <sup>2</sup> )	MAX ALLOWABLE WK <sup>2</sup> (lb-ft <sup>2</sup> )	NEMA LOAD WK <sup>2</sup> Sec	MAX ALLOWABLE WK <sup>2</sup> Sec	COLD	HOT
<b>734.00</b>	<b>110</b>	<b>90</b>	<b>210</b>	<b>83</b>	<b>1017</b>	<b>2034</b>	<b>5.49</b>	<b>10.57</b>	<b>2</b>	<b>1</b>

APPROVED:	<b>M. PRATER</b>	DRAWING NO.	<b>31057EPY2504</b>	REVISION:	<b>1</b>
-----------	------------------	-------------	---------------------	-----------	----------

DATE:  
December 2, 2005

# CONNECTION DIAGRAM

CATALOG NO.:  
EPY2504

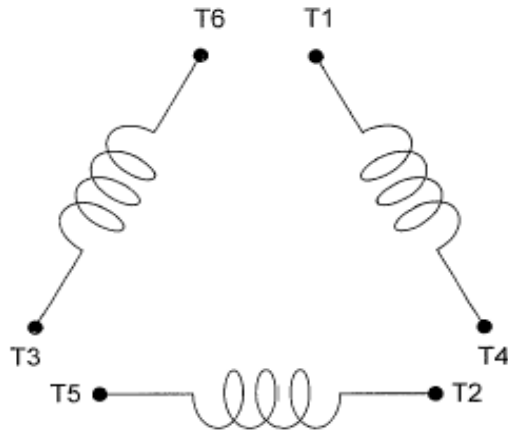

**SCHEMATIC -  $\Delta$  / Y CONNECTION**

## ACROSS THE LINE CONNECTION

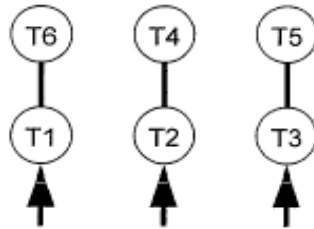

**460 VOLT CONNECTION**

## WYE START-DELTA RUN CONNECTION



**LINE  
460 VOLT START**



**LINE  
460 VOLT RUN**