

DATE DEC 12, 2013	OUTLINE DIMENSIONS 3-PHASE INDUCTION MOTOR	MODEL TYPE: AEGH
CATALOG NO. GH0/54		FRAME NO. A56

Pole	HP	KW	Hz	VOLT	Syn. Speed R. P. M
4	0.5	.37	60	230/460	1800

Ins.	Rating	Dimensions in	Approx Weight	Bearings
F	CONT.	inch	16.36 lbs	DE: 6204ZZ NDE: 6204ZZ

Totally Enclosed Fan Cooled  
Squirrel-Cage

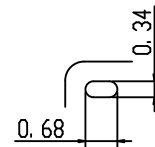
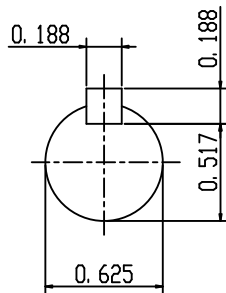
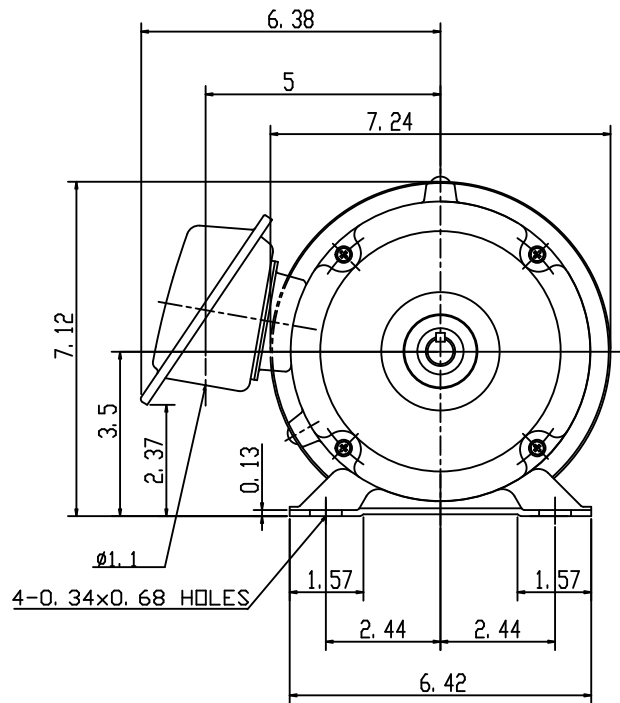
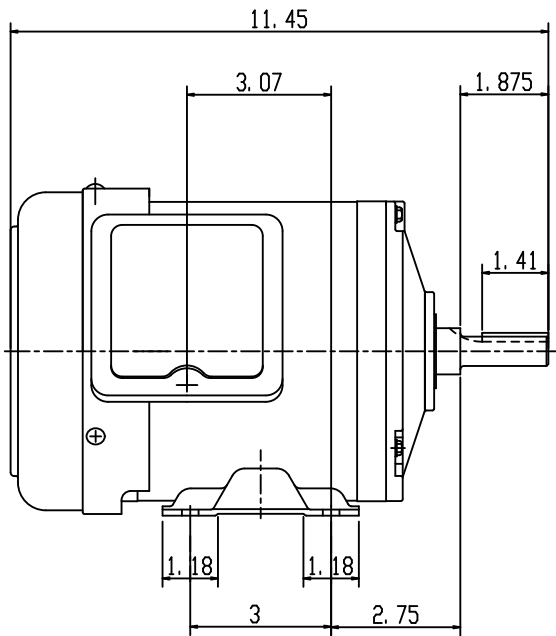

SCALE 4: 1

APPD.	W. H. TSAI	07 21 03		DWG NO.	31049Z105
CHKD.	J. B. CHEN	07 20 03		2204	
DWN.	Y. Y. CHEN	07 20 03			

# TECO Westinghouse

ISSUED <b>December 27, 2013</b>	<b>PERFORMANCE DATA</b>	ENCLOSURE <b>TEFC</b>
TYPE <b>AEGH</b>	<b>3-PHASE INDUCTION MOTOR</b>	CATALOG# <b>GH0/54</b>

### NAMEPLATE INFORMATION

OUTPUT		POLE	FRAME SIZE	VOLTAGE	HZ	RATED AMBIENT	INS. CLASS	NEMA DESIGN	TIME RATING	SERVICE FACTOR
HP	KW									
<b>1/2</b>	<b>0.37</b>	<b>4</b>	<b>56C</b>	<b>230/460</b>	<b>60</b>	<b>40°C</b>	<b>F</b>	<b>B</b>	<b>CONT.</b>	<b>1.15</b>

### TYPICAL PERFORMANCE

FULL LOAD RPM	EFFICIENCY				POWER FACTOR			MAXIMUM POWER FACTOR CORRECTION
	FULL LOAD		3/4 LOAD %	1/2 LOAD %	F. L. %	3/4 LOAD %	1/2 LOAD %	
	MIN. %	NOM. %						
<b>1735</b>	<b>74</b>	<b>77</b>	<b>74.5</b>	<b>70</b>	<b>73.5</b>	<b>64.5</b>	<b>51.5</b>	<b>0.4 KVAR</b>

### CURRENTS

NO LOAD			FULL LOAD			LOCKED ROTOR			NEMA KVA CODE LETTER
AT	AT	AT	AT	AT	AT	AT	AT	AT	
208 VOLT	230 VOLT	460 VOLT	208 VOLT	230 VOLT	460 VOLT	208 VOLT	230 VOLT	460 VOLT	
<b>0.85</b>	<b>1.04</b>	<b>0.52</b>	<b>1.83</b>	<b>1.65</b>	<b>0.83</b>	<b>10.85</b>	<b>12.00</b>	<b>6.00</b>	<b>L</b>

### TORQUE

### INERTIA

### ACCEL TIME

FULL LOAD lb-ft	LOCKED ROTOR %FLT	PULL UP %FLT	BREAK DOWN %FLT	ROTOR WR <sup>2</sup> lb-ft <sup>2</sup>	NEMA LOAD WK <sup>2</sup> lb-ft <sup>2</sup>	MAX ALLOWABLE WK <sup>2</sup> lb-ft <sup>2</sup>	NEMA LOAD WK <sup>2</sup> Sec	MAX ALLOWABLE WK <sup>2</sup> Sec
<b>1.5</b>	<b>275</b>	<b>265</b>	<b>370</b>	<b>0.037</b>	<b>3.0</b>	<b>17.4</b>	<b>3.89</b>	<b>22.35</b>

SAFE STALL TIME IN SECONDS		ALLOWABLE STARTS PER HOUR		SOUND PRESSURE LEVEL @ 3 FT dB(A)
COLD	HOT	COLD	HOT	
<b>56</b>	<b>39</b>	<b>2</b>	<b>1</b>	

APPROVED:	<b>M. PRATER</b>	DRAWING NO.	<b>31057GH0/54</b>	REVISION <b>0</b>
-----------	------------------	-------------	--------------------	-------------------

DATE:  
December 12, 2013

# CONNECTION DIAGRAM

CATALOG NO.:  
GH0/54

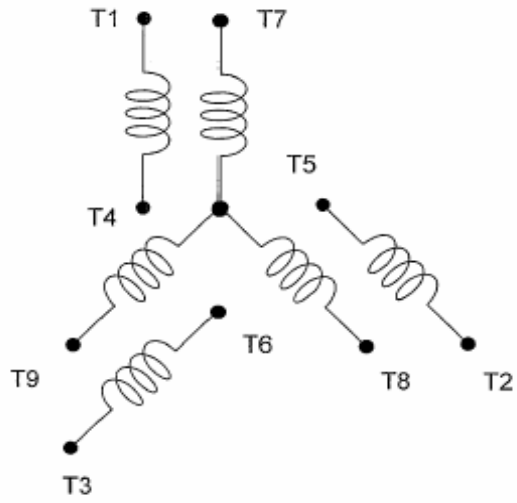

**SCHEMATIC - 2Y/Y CONNECTION**

## ACROSS THE LINE CONNECTION

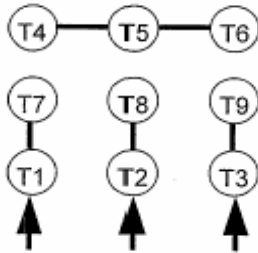

**LINE**  
**230 VOLT CONNECTION**

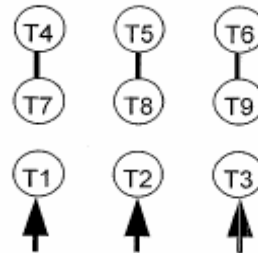

**LINE**  
**460 VOLT CONNECTION**



DWG NO.  
**DAC-1566-2**