

DATE DEC 4, 2014	OUTLINE DIMENSIONS 3-PHASE INDUCTION MOTOR	MODEL TYPE: AEGH
CATALOG NO. GH0/56		FRAME NO. A56

Pole	HP	KW	Hz	VOLT	Syn. Speed R. P. M
6	1/2	.373	60	230/460	1200

Ins.	Rating	Dimensions in	Approx Weight	Bearings	
F	CONT.	inch	37 lbs	DE: 6204ZZ	NDE: 6203ZZ

Totally Enclosed Fan Cooled
Squirrel-Cage

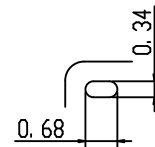
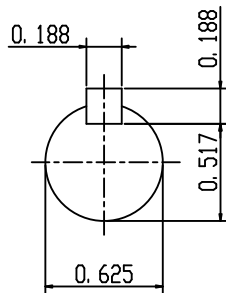
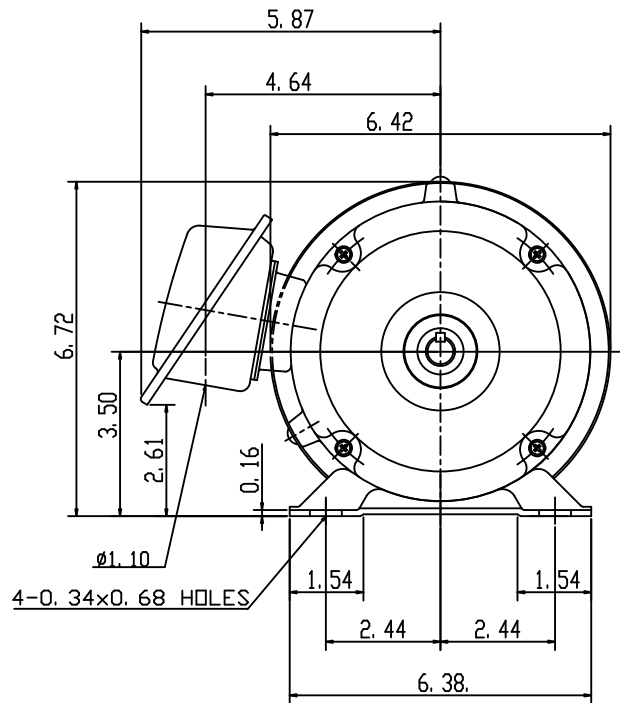
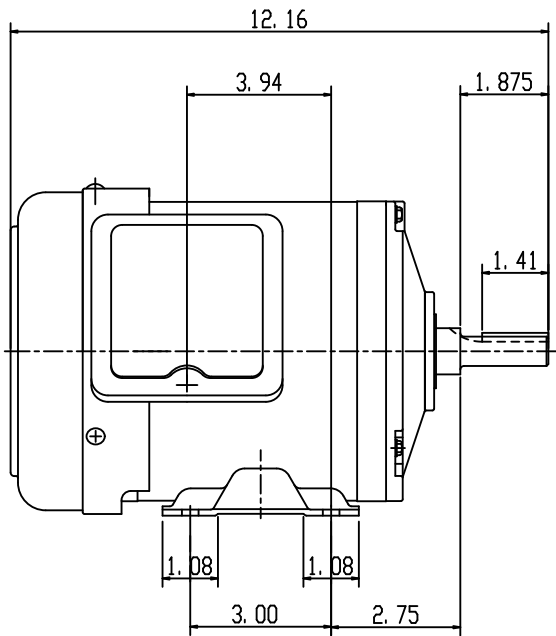

SCALE 4: 1

APPD.	W. H. TSAI	07 21 03		DWG NO.	31049Z105
CHKD.	J. B. CHEN	07 20 03		2204	
DWN.	Y. Y. CHEN	07 20 03			

TECO Westinghouse

ISSUED April 16, 2018	PERFORMANCE DATA	ENCLOSURE TEFC
TYPE AEGH	3-PHASE INDUCTION MOTOR	CATALOG# GH0/56

NAMEPLATE INFORMATION

OUTPUT		POLE	FRAME SIZE	VOLTAGE	HZ	RATED AMBIENT	INS. CLASS	NEMA DESIGN	TIME RATING	SERVICE FACTOR
HP	KW									
1/2	0.37	4	56C	230/460	60	40°C	F	B	CONT.	1.15

TYPICAL PERFORMANCE

FULL LOAD RPM	EFFICIENCY				POWER FACTOR			MAXIMUM POWER FACTOR CORRECTION
	FULL LOAD		3/4 LOAD %	1/2 LOAD %	F. L. %	3/4 LOAD %	1/2 LOAD %	
	MIN. %	NOM. %						
1145	72	75.5	73.6	68	63	53	40.5	0.5 KVAR

CURRENTS

NO LOAD			FULL LOAD			LOCKED ROTOR			NEMA KVA CODE LETTER
AT	AT	AT	AT	AT	AT	AT	AT	AT	
208 VOLT	230 VOLT	460 VOLT	208 VOLT	230 VOLT	460 VOLT	208 VOLT	230 VOLT	460 VOLT	
1.00	1.24	0.62	2.18	1.97	0.99	10.85	12.00	6.00	L

TORQUE

INERTIA

ACCEL TIME

FULL LOAD lb-ft	LOCKED ROTOR %FLT	PULL UP %FLT	BREAK DOWN %FLT	ROTOR WR ² lb-ft ²	NEMA LOAD WK ² lb-ft ²	MAX ALLOWABLE WK ² lb-ft ²	NEMA LOAD WK ² Sec	MAX ALLOWABLE WK ² Sec
2.293	305	295	380	0.079	8.0	24.0	4.25	12.66

SAFE STALL TIME IN SECONDS

ALLOWABLE STARTS PER HOUR

SOUND PRESSURE LEVEL @ 3 FT dB(A)

COLD	HOT	COLD	HOT	55.8
50	35	2	1	

APPROVED:	M. PRATER	DRAWING NO.	31057GH0/54	REVISION 0
-----------	------------------	-------------	--------------------	-------------------

DATE:
December 12, 2013

CONNECTION DIAGRAM

CATALOG NO.:
GH0/56

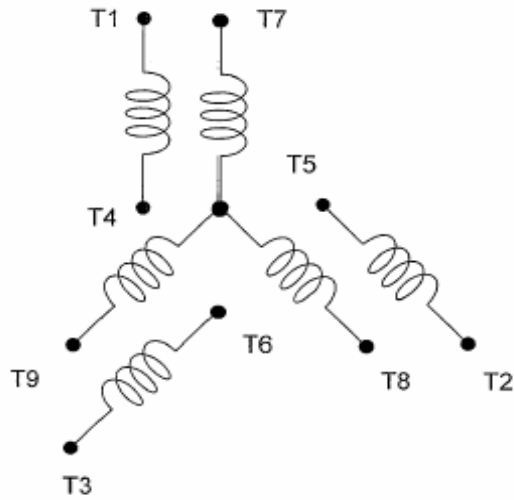

SCHEMATIC - 2Y/Y CONNECTION

ACROSS THE LINE CONNECTION

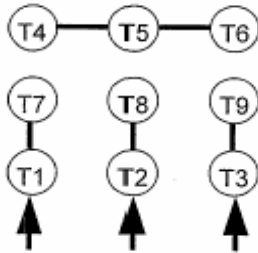

LINE
230 VOLT CONNECTION

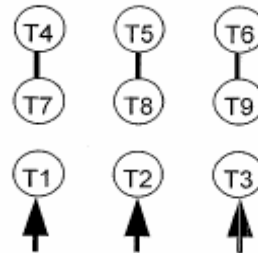

LINE
460 VOLT CONNECTION



DWG NO.
DAC-1566-2