

DATE  
JAN 19, 2012

CATALOG NO.  
GHV0/32C

OUTLINE DIMENSIONS  
3-PHASE INDUCTION MOTOR

MODEL TYPE:  
AETHCF

FRAME NO. 56C

Pole	HP	KW	Hz	VOLT	Syn. Speed R. P. M
2	1/3	.22	60	230/460	3600

Ins.	Rating	Dimensions in	Approx Weight	Bearings
F	CONT.	inch	24 lbs.	DF: 6204ZZ NDE: 6203ZZ

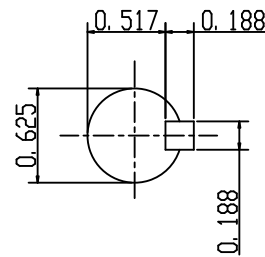
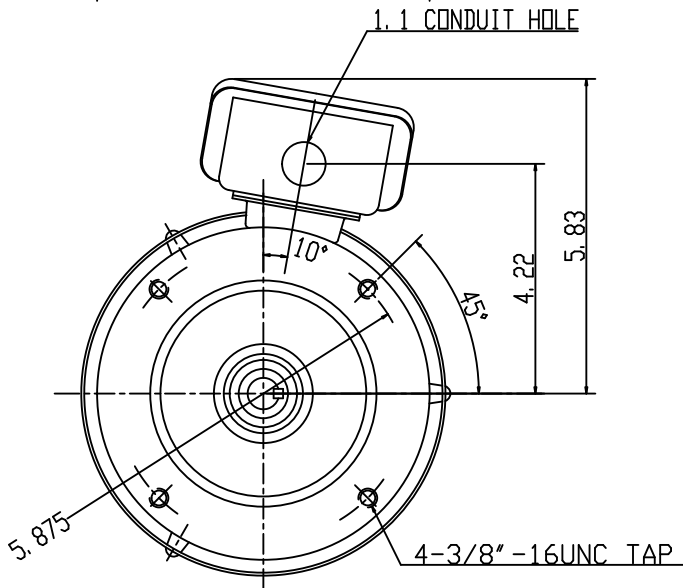
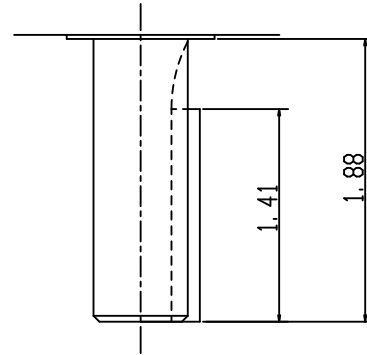
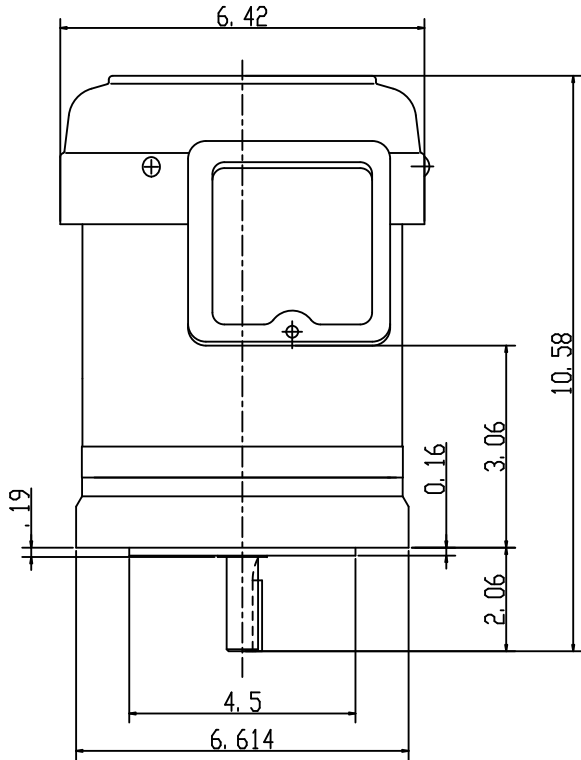

APPD.	W. H. TSAI	03 31 03
CHKD.	J. B. CHEN	03 31 03
DWN.	P. J. CHEN	03 31 03

TECO   Westinghouse

DWG NO.  
31049Z105  
0724

# TECO Westinghouse

ISSUED <b>December 14, 2012</b>	<b>PERFORMANCE DATA</b>	ENCLOSURE <b>TEFC</b>
TYPE <b>AETHCF</b>	<b>3-PHASE INDUCTION MOTOR</b>	CATALOG# <b>GHV0/34C</b>

### NAMEPLATE INFORMATION

OUTPUT		POLE	FRAME SIZE	VOLTAGE	HZ	RATED AMBIENT	INS. CLASS	NEMA DESIGN	TIME RATING	SERVICE FACTOR
HP	KW									
<b>1/3</b>	<b>0.25</b>	<b>4</b>	<b>56C</b>	<b>230/460</b>	<b>60</b>	<b>40°C</b>	<b>F</b>	<b>B</b>	<b>CONT.</b>	<b>1.15</b>

### TYPICAL PERFORMANCE

FULL LOAD RPM	EFFICIENCY				POWER FACTOR			MAXIMUM POWER FACTOR CORRECTION
	FULL LOAD		3/4 LOAD	1/2 LOAD	F. L.	3/4 LOAD	1/2 LOAD	
	MIN. %	NOM. %						
<b>1735</b>	<b>72</b>	<b>75.5</b>	<b>74</b>	<b>69</b>	<b>74.5</b>	<b>64.5</b>	<b>51</b>	<b>0.3 KVAR</b>

### CURRENTS

NO LOAD			FULL LOAD			LOCKED ROTOR			NEMA KVA CODE LETTER
AT	AT	AT	AT	AT	AT	AT	AT	AT	
208 VOLT	230 VOLT	460 VOLT	208 VOLT	230 VOLT	460 VOLT	208 VOLT	230 VOLT	460 VOLT	
<b>0.62</b>	<b>0.76</b>	<b>0.38</b>	<b>1.23</b>	<b>1.11</b>	<b>0.55</b>	<b>5.72</b>	<b>7.00</b>	<b>3.50</b>	<b>K</b>

### TORQUE

### INERTIA

### ACCEL TIME

FULL LOAD lb-ft	LOCKED ROTOR %FLT	PULL UP %FLT	BREAK DOWN %FLT	ROTOR WR <sup>2</sup> lb-ft <sup>2</sup>	NEMA LOAD WK <sup>2</sup> lb-ft <sup>2</sup>	MAX ALLOWABLE WK <sup>2</sup> lb-ft <sup>2</sup>	NEMA LOAD WK <sup>2</sup> Sec	MAX ALLOWABLE WK <sup>2</sup> Sec
<b>1.01</b>	<b>235</b>	<b>225</b>	<b>330</b>	<b>0.033</b>	<b>2.1</b>	<b>12.6</b>	<b>4.58</b>	<b>27.10</b>

SAFE STALL TIME IN SECONDS

ALLOWABLE STARTS PER HOUR

SOUND PRESSURE LEVEL @ 3 FT dB(A)

COLD	HOT	COLD	HOT	55.8
<b>72</b>	<b>50</b>	<b>2</b>	<b>1</b>	

APPROVED:	<b>M. PRATER</b>	DRAWING NO.	<b>31057GHV0/34C</b>	REVISION <b>0</b>
-----------	------------------	-------------	----------------------	-------------------

DATE:  
April 28, 2009

# CONNECTION DIAGRAM

GHV0\_34C

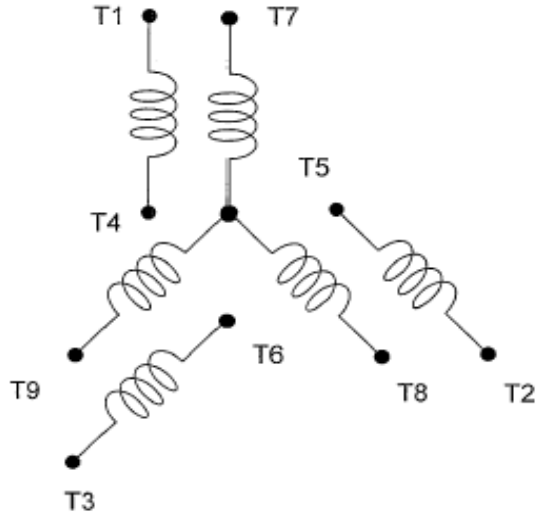

**SCHEMATIC - 2Y/Y CONNECTION**

## ACROSS THE LINE CONNECTION

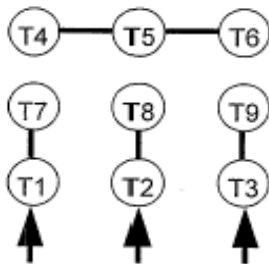

**LINE  
230 VOLT CONNECTION**

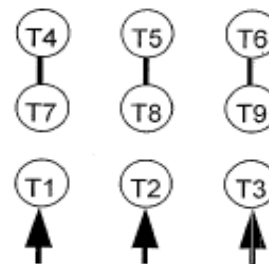

**LINE  
460 VOLT CONNECTION**