

DATE
Jan 19, 2012

CATALOG NO.
GHV0/76C

OUTLINE DIMENSIONS
3-PHASE INDUCTION MOTOR

MODEL TYPE:
AETHCF

FRAME NO. 56C

Pole	HP	KW	Hz	VOLT	Syn. Speed R. P. M
6	3/4	.56	60	230/460	1200

Ins.	Rating	Dimensions in	Approx Weight	Bearings
F	CONT.	inch	29 lbs.	DF: 6204ZZ NDE: 6203ZZ

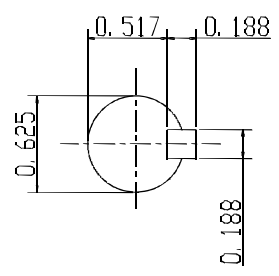
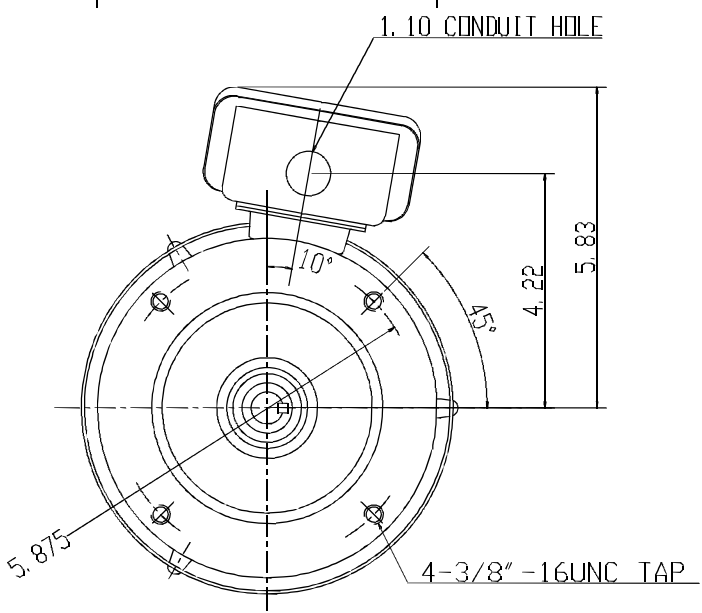
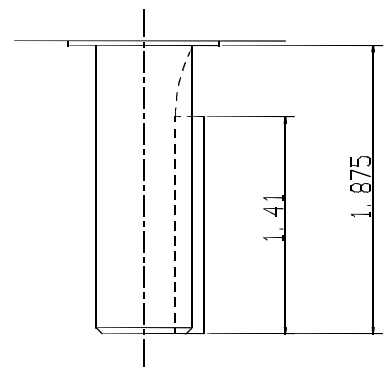
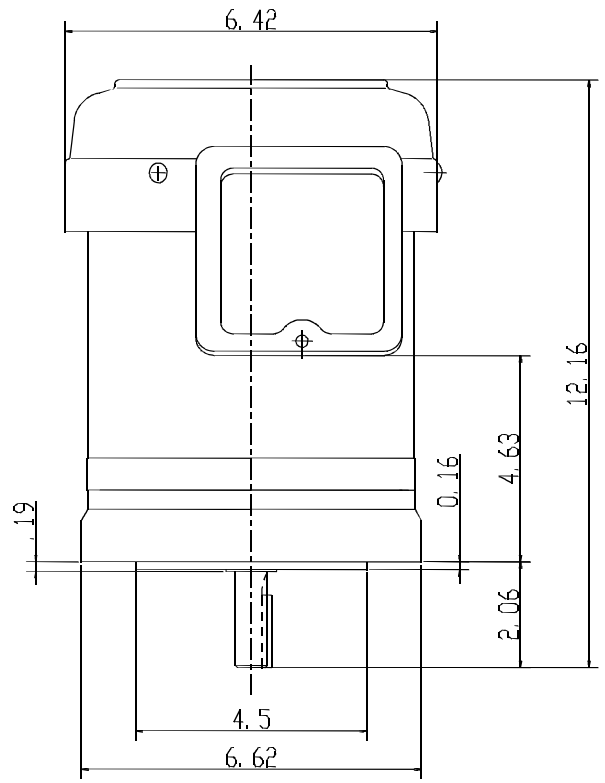

--	--	--	--	--	--	--	--

APPD.	W. H. TSAT	03 31 03
CHKD.	J. B. CHEN	03 31 03
DWN.	P. J. CHEN	03 31 03



DWG NO.
31049Z105
0717

TECO Westinghouse

ISSUED November 25, 2014	PERFORMANCE DATA	ENCLOSURE TEFC
TYPE AETHCF	3-PHASE INDUCTION MOTOR	CATALOG# GHV0/76C

NAMEPLATE INFORMATION

OUTPUT		POLE	FRAME SIZE	VOLTAGE	HZ	RATED AMBIENT	INS. CLASS	NEMA DESIGN	TIME RATING	SERVICE FACTOR
HP	KW									
3/4	0.56	6	56C	230/460	60	40°C	F	B	CONT.	1.15

TYPICAL PERFORMANCE

FULL LOAD RPM	EFFICIENCY				POWER FACTOR			MAXIMUM POWER FACTOR CORRECTION
	FULL LOAD		3/4 LOAD	1/2 LOAD	F. L.	3/4 LOAD	1/2 LOAD	
	MIN. %	NOM. %						
1145	75.5	78.5	77.5	73.5	72	64	51	0.8 KVAR

CURRENTS

NO LOAD			FULL LOAD			LOCKED ROTOR			NEMA KVA CODE LETTER
AT	AT	AT	AT	AT	AT	AT	AT	AT	
208 VOLT	230 VOLT	460 VOLT	208 VOLT	230 VOLT	460 VOLT	208 VOLT	230 VOLT	460 VOLT	
2.26	2.04	1.02	2.75	2.48	1.24	17.69	16.00	8.00	K

TORQUE

INERTIA

ACCEL TIME

FULL LOAD lb-ft	LOCKED ROTOR %FLT	PULL UP %FLT	BREAK DOWN %FLT	ROTOR WR ² lb-ft ²	NEMA LOAD WK ² lb-ft ²	MAX ALLOWABLE WK ² lb-ft ²	NEMA LOAD WK ² Sec	MAX ALLOWABLE WK ² Sec
3.4	190	180	285	0.095	11.8	64.9	5.82	31.94

SAFE STALL TIME IN SECONDS

ALLOWABLE STARTS PER HOUR

SOUND PRESSURE LEVEL @ 3 FT dB(A)

COLD	HOT	COLD	HOT	54.2
61	42	2	1	

APPROVED:	M. PRATER	DRAWING NO.	31057GHV0/76C	REVISION 0
-----------	------------------	-------------	----------------------	-------------------

DATE:
January 31, 2012

CONNECTION DIAGRAM

CATALOG NO.:
GHV0/76C

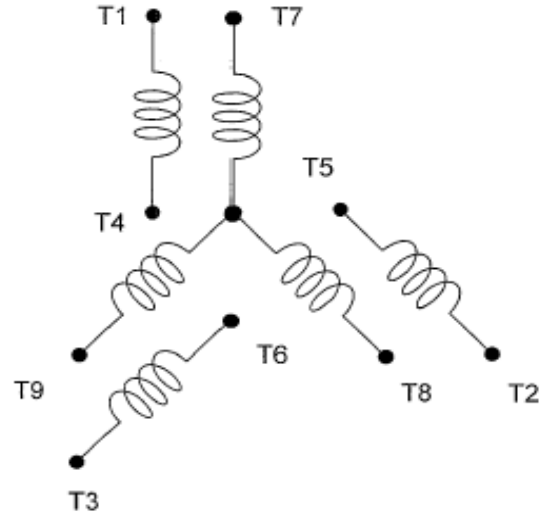

SCHEMATIC - 2Y/Y CONNECTION

ACROSS THE LINE CONNECTION

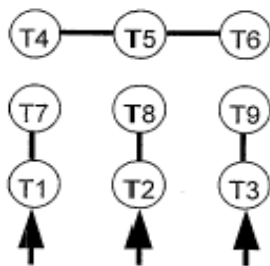

**LINE
230 VOLT CONNECTION**

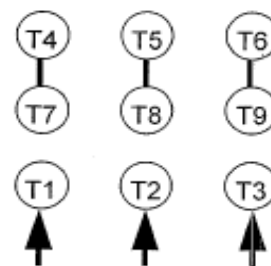

**LINE
460 VOLT CONNECTION**