

DATE
NOVEMBER 12, 2014

OUTLINE DIMENSIONS
3-PHASE INDUCTION MOTOR

MOTOR TYPE:
AEGH-CF
FRAME NO. 143TC

CAT. #: GP0014C

Pole	HP	kW	Hz	VOLT	Syn.Speed r/min(rpm)
4	1.5	1.12	60	230/460	1800

Ins	Rating	Dimension in	Approx Weight	Bearings
F	CONT.	inch.	41 lbs.	DE: 6205ZZ NDE: 6204ZZ

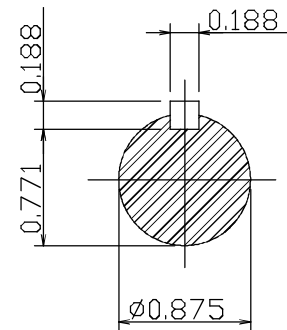
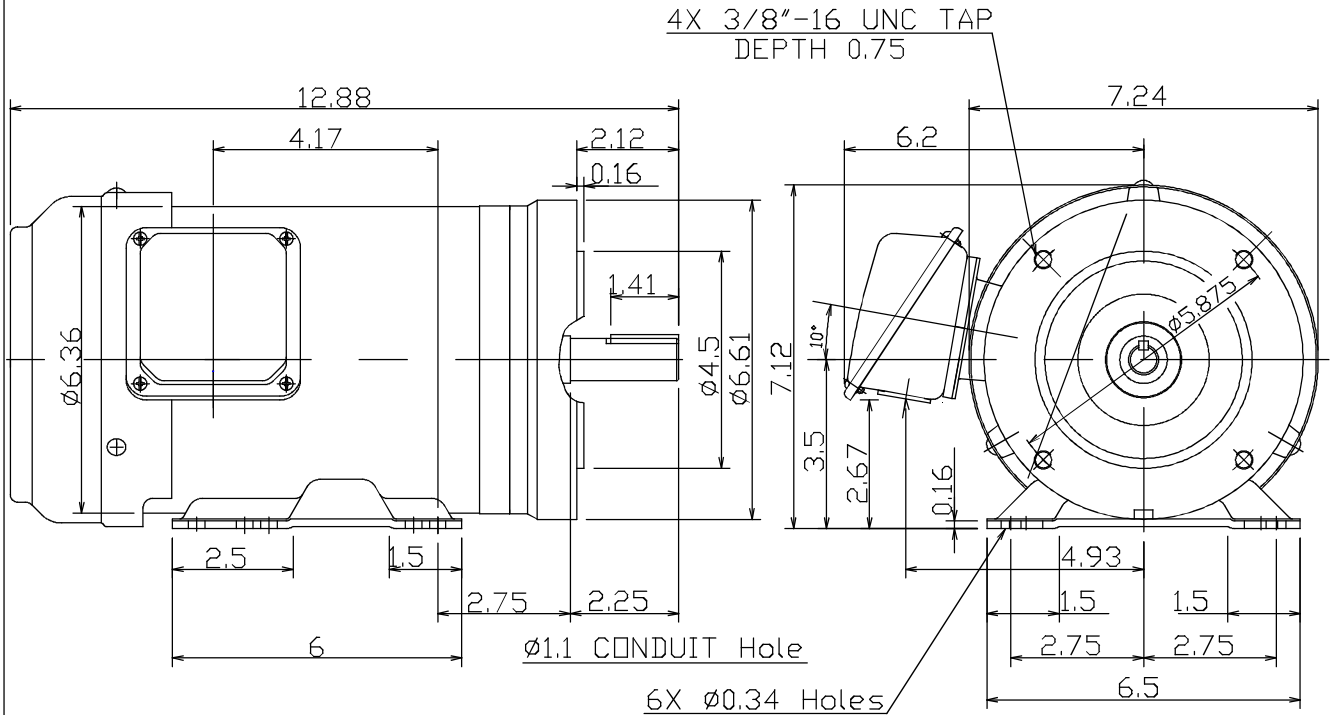

--	--	--	--

DWN.	Y.Y.CHEN	09-22-09
CHKD.	C.Y.CHEN	09-23-09
APPD.	M.C.TSAI	09-23-09



DWG NO.
31049Z107730

TECO Westinghouse

ISSUED 11/12/14	PERFORMANCE DATA	ENCLOSURE TEFC
TYPE AEGH-CF	3-PHASE INDUCTION MOTOR	CATALOG# GP0014C

NAMEPLATE INFORMATION

OUTPUT		POLE	FRAME SIZE	VOLTAGE	HZ	RATED AMBIENT	INS. CLASS	NEMA DESIGN	TIME RATING	SERVICE FACTOR
HP	KW									
1	0.75	4	143TC	230/460	60	40°C	F	B	CONT.	1.15

TYPICAL PERFORMANCE

FULL LOAD RPM	EFFICIENCY				POWER FACTOR			MAXIMUM POWER FACTOR CORRECTION
	FULL LOAD		3/4 LOAD %	1/2 LOAD %	F. L. %	3/4 LOAD %	1/2 LOAD %	
	MIN. %	NOM. %						
1750	82.5	85.5	85.0	82.0	75.5	67.0	54.0	0.57 KVAR

CURRENTS

NO LOAD			FULL LOAD			LOCKED ROTOR			NEMA KVA CODE LETTER
AT	AT	AT	AT	AT	AT	AT	AT	AT	
208 VOLT	230 VOLT	460 VOLT	208 VOLT	230 VOLT	460 VOLT	208 VOLT	230 VOLT	460 VOLT	
1.47	1.80	0.90	3.21	2.90	1.45	27.13	30.00	15.00	N

TORQUE

INERTIA

ACCEL TIME

FULL LOAD lb-ft	LOCKED ROTOR %FLT	PULL UP %FLT	BREAK DOWN %FLT	ROTOR WR ² lb-ft ²	NEMA LOAD WK ² lb-ft ²	MAX ALLOWABLE WK ² lb-ft ²	NEMA LOAD WK ² Sec	MAX ALLOWABLE WK ² Sec
3.00	365	310	410	0.1	5.8	17.4	3.25	9.65

SAFE STALL TIME IN SECONDS

ALLOWABLE STARTS PER HOUR

SOUND PRESSURE LEVEL @ 3 FT dB(A)

COLD	HOT	COLD	HOT	54
40	28	2	1	

APPROVED:	M. PRATER	DRAWING NO.	31057GP0014C	REVISION	0
-----------	------------------	-------------	---------------------	----------	----------

DATE:
May 28, 2009

CONNECTION DIAGRAM

CATALOG NO.:
GP0014C

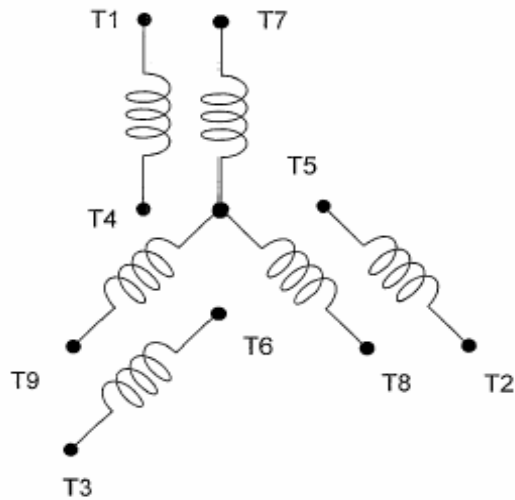

SCHEMATIC - 2Y/Y CONNECTION

ACROSS THE LINE CONNECTION

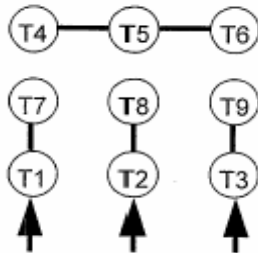

LINE
230 VOLT CONNECTION

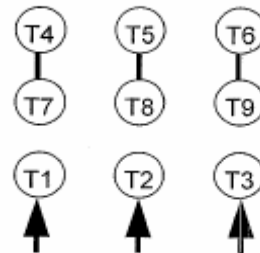

LINE
460 VOLT CONNECTION

TECO  **Westinghouse**

DWG NO.
DAC-1566-2