

DATE  
OCTOBER 27, 2009  
CAT. #: GP0026C

OUTLINE DIMENSIONS  
3-PHASE INDUCTION MOTOR

MOTOR TYPE:  
AEGH-CF  
FRAME NO. 184TC

Pole	HP	kW	Hz	VOLT	Syn.Speed r/min(rpm)
6	2	1.50	60	230/460	1200

Ins	Rating	Dimension in	Approx Weight	Bearings
F	CONT.	inches	84 lbs.	DE: 6206ZZC3 NDE: 6205ZZC3

Totally Enclosed Fan-Cooled Type. Squirrel-Cage Rotor.

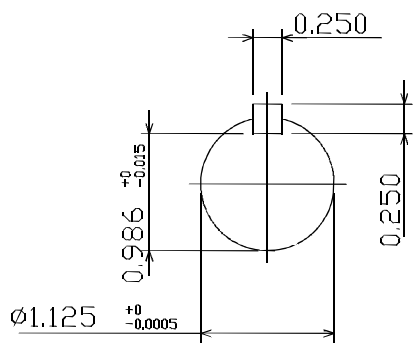
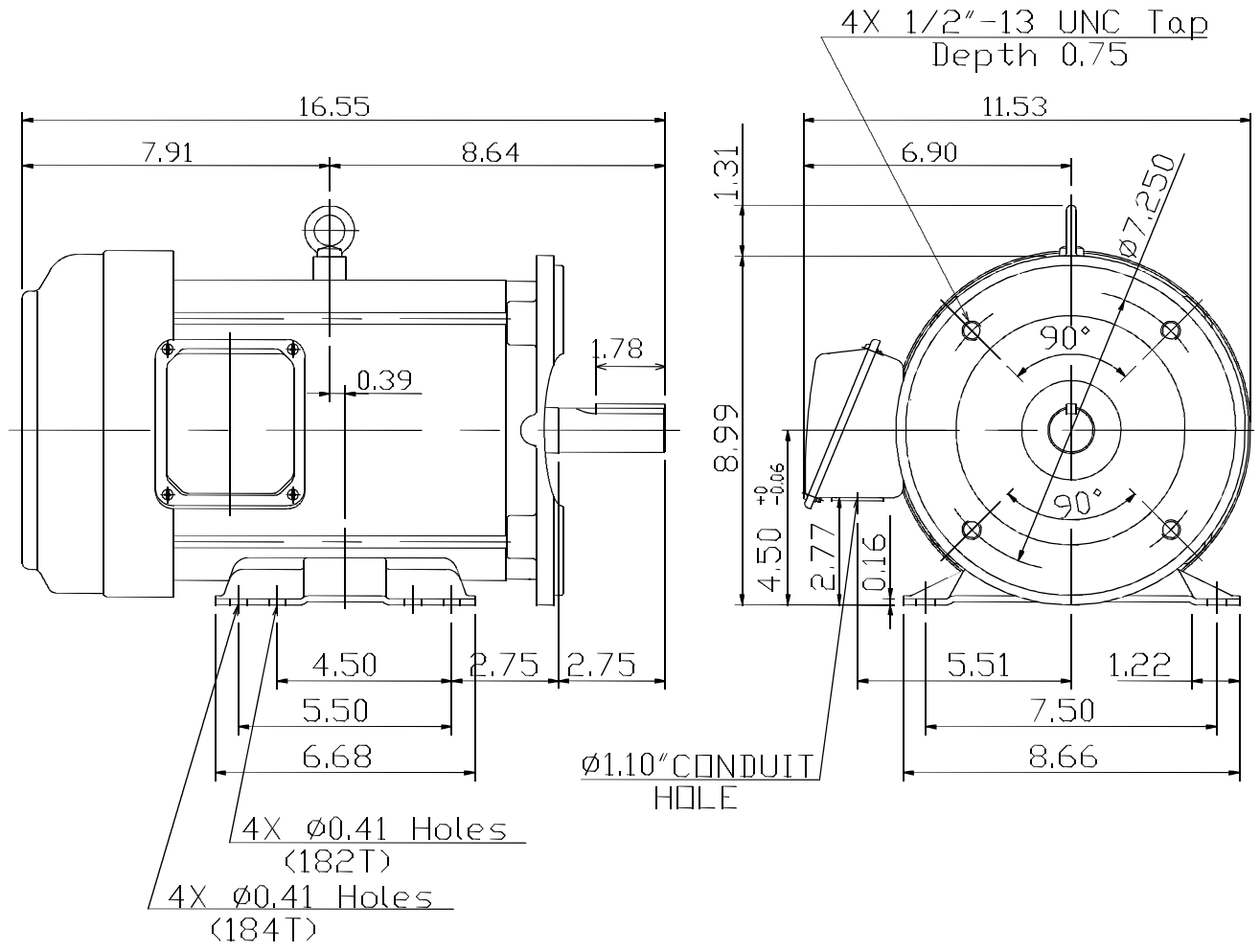

DWN.	Y.S.LIN	10 05 09
CHKD.	J.H.LIANG	10 06 09
APPD.	M.C.TSAI	10 06 09



DWG NO.  
31049R171020

# TECO Westinghouse

ISSUED <b>12/27/13</b>	<b>PERFORMANCE DATA</b>	ENCLOSURE <b>TEFC</b>
TYPE <b>AEGHCF</b>	<b>3-PHASE INDUCTION MOTOR</b>	CATALOG# <b>GP0026C</b>

### NAMEPLATE INFORMATION

OUTPUT		POLE	FRAME SIZE	VOLTAGE	HZ	RATED AMBIENT	INS. CLASS	NEMA DESIGN	TIME RATING	SERVICE FACTOR
HP	KW									
<b>2</b>	<b>1.49</b>	<b>6</b>	<b>184T</b>	<b>230/460</b>	<b>60</b>	<b>40°C</b>	<b>F</b>	<b>B</b>	<b>CONT.</b>	<b>1.15</b>

### TYPICAL PERFORMANCE

FULL LOAD RPM	EFFICIENCY				POWER FACTOR			MAXIMUM POWER FACTOR CORRECTION
	FULL LOAD		3/4 LOAD %	1/2 LOAD %	F. L. %	3/4 LOAD %	1/2 LOAD %	
	MIN. %	NOM. %						
<b>1165</b>	<b>86.5</b>	<b>88.5</b>	<b>87.5</b>	<b>85.5</b>	<b>64.5</b>	<b>53.0</b>	<b>41.0</b>	<b>1.52 KVAR</b>

### CURRENTS

NO LOAD			FULL LOAD			LOCKED ROTOR			NEMA KVA CODE LETTER
AT	AT	AT	AT	AT	AT	AT	AT	AT	
208 VOLT	230 VOLT	460 VOLT	208 VOLT	230 VOLT	460 VOLT	208 VOLT	230 VOLT	460 VOLT	
<b>3.68</b>	<b>4.50</b>	<b>2.25</b>	<b>7.25</b>	<b>6.56</b>	<b>3.28</b>	<b>45.22</b>	<b>50.00</b>	<b>25.00</b>	<b>L</b>

### TORQUE

### INERTIA

### ACCEL TIME

FULL LOAD lb-ft	LOCKED ROTOR %FLT	PULL UP %FLT	BREAK DOWN %FLT	ROTOR WR <sup>2</sup> lb-ft <sup>2</sup>	NEMA LOAD WK <sup>2</sup> lb-ft <sup>2</sup>	MAX ALLOWABLE WK <sup>2</sup> lb-ft <sup>2</sup>	NEMA LOAD WK <sup>2</sup> Sec	MAX ALLOWABLE WK <sup>2</sup> Sec
<b>9.01</b>	<b>160</b>	<b>150</b>	<b>270</b>	<b>0.419</b>	<b>30</b>	<b>90</b>	<b>6.23</b>	<b>18.52</b>

SAFE STALL TIME IN SECONDS

ALLOWABLE STARTS PER HOUR

SOUND PRESSURE LEVEL @ 3 FT dB(A)

COLD	HOT	COLD	HOT	50
<b>95</b>	<b>67</b>	<b>2</b>	<b>1</b>	

APPROVED:	<b>M. PRATER</b>	DRAWING NO.	<b>31057GP0026C</b>	REVISION <b>0</b>
-----------	------------------	-------------	---------------------	-------------------

DATE:  
May 28, 2009

# CONNECTION DIAGRAM

CATALOG NO.:  
GP----C



**SCHEMATIC - 2Y/Y CONNECTION**

## ACROSS THE LINE CONNECTION



**LINE**  
**230 VOLT CONNECTION**



**LINE**  
**460 VOLT CONNECTION**

**TECO**  **Westinghouse**

DWG NO.  
**DAC-1566-2**