

DATE
MAY 28, 2009
CATALOG # GP1/52G

OUTLINE DIMENSIONS
3-PHASE INDUCTION MOTOR

MOTOR TYPE:
AEGH-SGR
FRAME NO. 143T

Pole	HP	kW	Hz	VOLT	r/min
2	1.5	1.12	60	230/460	3600

Ins	Rating	Dimension in	Approx Weight	Bearings
F	CONT.	inch.	29 lbs.	DE: 6205ZZ NDE: 6204ZZ

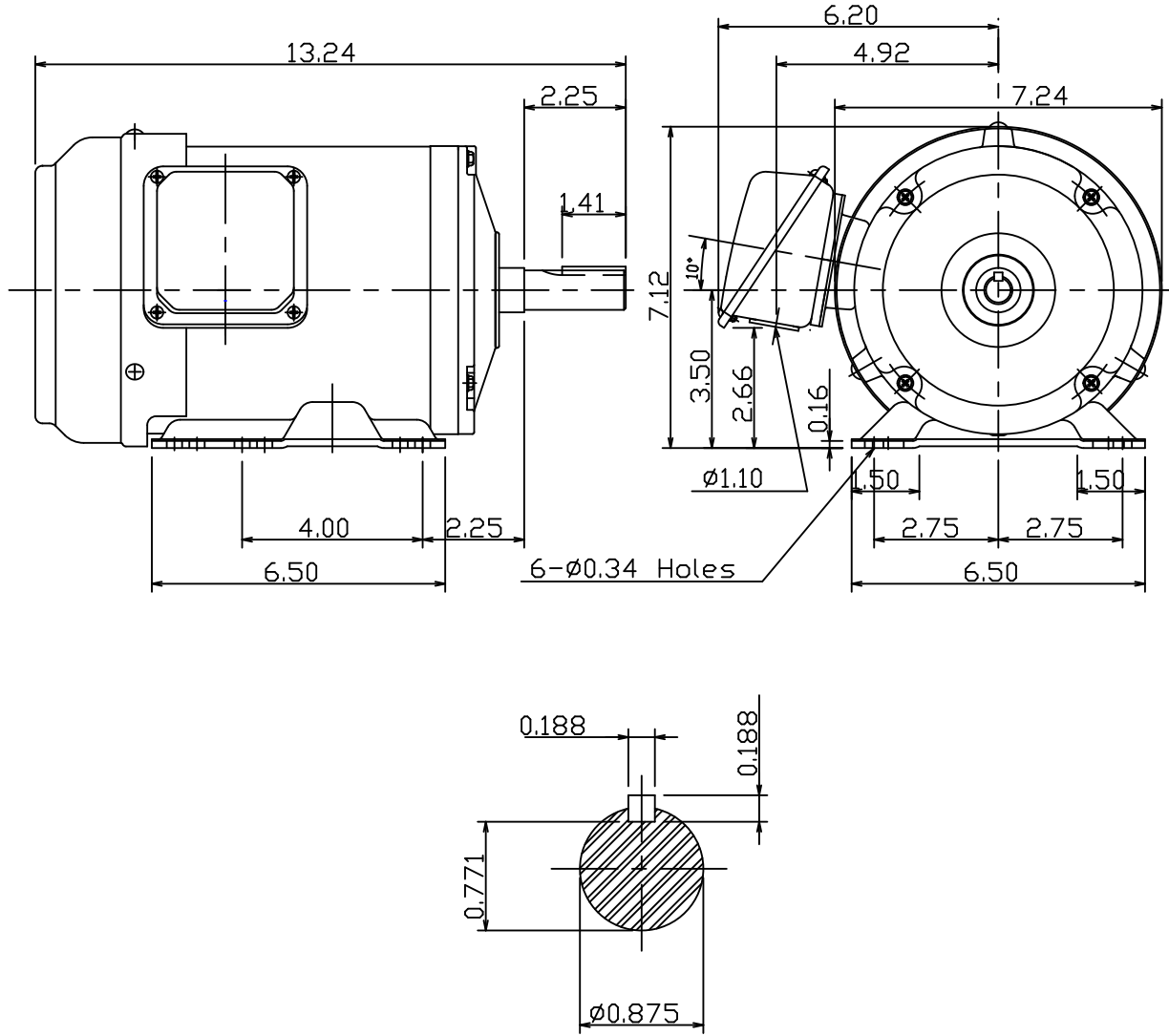

NOTE:
1. Shaft Grounding Ring Installed



DWN.	陳奕元	04-09-09
CHKD.	陳敬元	04-09-09
APPD.	蔡明 ^o	04-09-09

東元電機股份有限公司
TECO Electric & Machinery Co., Ltd.
TAIWAN

DWG NO.
31049Z107470

TECO Westinghouse

ISSUED 12/27/13	PERFORMANCE DATA	ENCLOSURE TEFC
TYPE AEGH-SGR	3-PHASE INDUCTION MOTOR	CATALOG# GP1/52G

NAMEPLATE INFORMATION

OUTPUT		POLE	FRAME SIZE	VOLTAGE	HZ	RATED AMBIENT	INS. CLASS	NEMA DESIGN	TIME RATING	SERVICE FACTOR
HP	KW									
1.5	1.12	2	143T	230/460	60	40°C	F	B	CONT.	1.15

TYPICAL PERFORMANCE

FULL LOAD RPM	EFFICIENCY				POWER FACTOR			MAXIMUM POWER FACTOR CORRECTION
	FULL LOAD		3/4 LOAD %	1/2 LOAD %	F. L. %	3/4 LOAD %	1/2 LOAD %	
	MIN. %	NOM. %						
3505	81.5	84.0	83.0	80.0	87.5	82.0	71.0	0.64 KVAR

CURRENTS

NO LOAD			FULL LOAD			LOCKED ROTOR			NEMA KVA CODE LETTER
AT	AT	AT	AT	AT	AT	AT	AT	AT	
208 VOLT	230 VOLT	460 VOLT	208 VOLT	230 VOLT	460 VOLT	208 VOLT	230 VOLT	460 VOLT	
1.55	1.90	0.95	4.22	3.82	1.91	36.17	40.00	20.00	M

TORQUE

INERTIA

ACCEL TIME

FULL LOAD lb-ft	LOCKED ROTOR %FLT	PULL UP %FLT	BREAK DOWN %FLT	ROTOR WR ² lb-ft ²	NEMA LOAD WK ² lb-ft ²	MAX ALLOWABLE WK ² lb-ft ²	NEMA LOAD WK ² Sec	MAX ALLOWABLE WK ² Sec
2.25	200	200	350	0.055	1.8	5.4	3.63	10.68

SAFE STALL TIME IN SECONDS

ALLOWABLE STARTS PER HOUR

SOUND PRESSURE LEVEL @ 3 FT dB(A)

COLD	HOT	COLD	HOT	
17	12	2	1	

APPROVED:	M. PRATER	DRAWING NO.	31057GP1/52G	REVISION 0
-----------	------------------	-------------	---------------------	-------------------

DATE:
May 28, 2009

CONNECTION DIAGRAM

CATALOG NO.:
GP1/52G

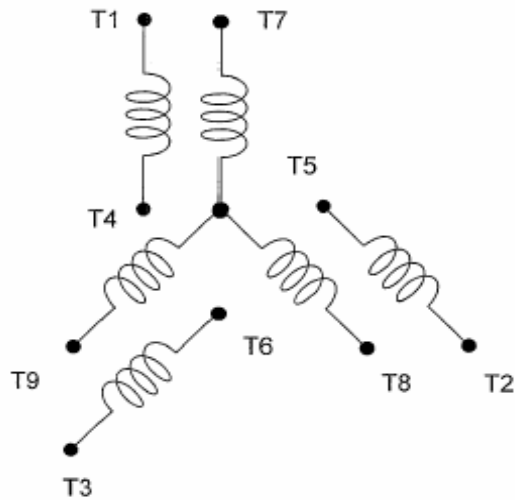

SCHEMATIC - 2Y/Y CONNECTION

ACROSS THE LINE CONNECTION



LINE
230 VOLT CONNECTION

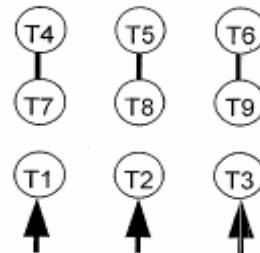

LINE
460 VOLT CONNECTION

TECO  **Westinghouse**

DWG NO.
DAC-1566-2