

PRODUCT INFORMATION PACKET

marathon®
Motors

Model No: 215TTFBD6005

Catalog No: GT13174

Globetrotter® General Purpose Motor, 15 HP, 3 Ph, 60 Hz, 230/460 V, 3600 RPM, 215TC Frame, TEFC



Regal and Marathon are trademarks of Regal Rexnord Corporation or one of its affiliated companies.
©2022 Regal Rexnord Corporation, All Rights Reserved. MC017097E

RegalRexnord



Nameplate Specifications

Output HP	15 Hp	Output KW	11.2 kW
Frequency	60 Hz	Voltage	230/460 V
Current	35.0/17.4 A	Speed	3530 rpm
Service Factor	1.15	Phase	3
Efficiency	91.7 %	Power Factor	88
Duty	Continuous	Insulation Class	F
Design Code	A	KVA Code	J
Frame	215TC	Enclosure	Totally Enclosed Fan Cooled
Thermal Protection	No Protection	Ambient Temperature	40 °C
Drive End Bearing Size	6307	Opp Drive End Bearing Size	6206
UL	Listed	CSA	Y
CE	Y	IP Code	43
Hazardous Location	DIVISION 2 T2B	Number of Speeds	1

Technical Specifications

Electrical Type	Squirrel Cage Inverter Rated	Starting Method	Line Or Inverter
Poles	2	Rotation	Reversible
Resistance Main	.56 Ohms	Mounting	Round
Motor Orientation	Horizontal	Drive End Bearing	Ball
Opp Drive End Bearing	Ball	Frame Material	Rolled Steel
Shaft Type	T	Shaft Diameter	1.375 in
Assembly/Box Mounting	F1/F2 CAPABLE	Inverter Load	CONSTANT 2:1/VARIABLE 10:1
Connection Drawing	EE7308	Outline Drawing	SS620712-200

This is an uncontrolled document once printed or downloaded and is subject to change without notice. Date Created:11/29/2022

DASH NO.	4		3		MOUNTING	FRAME
	C	AG	AH	BV		
100	19.12	16.00	3.12	9.95	F1 OR F2	213TC
200	20.62	17.50		11.45		215TC

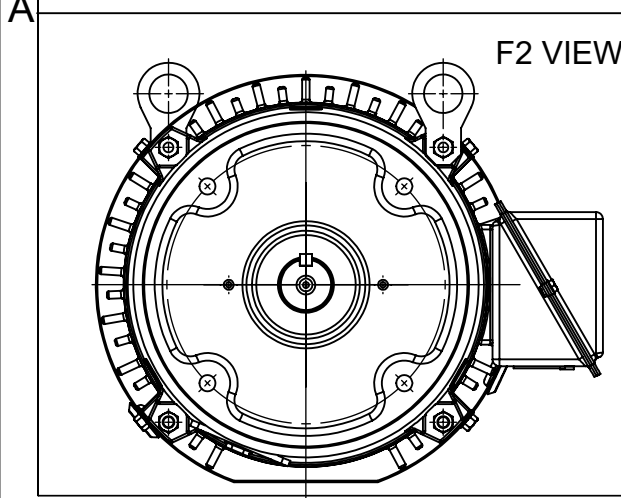
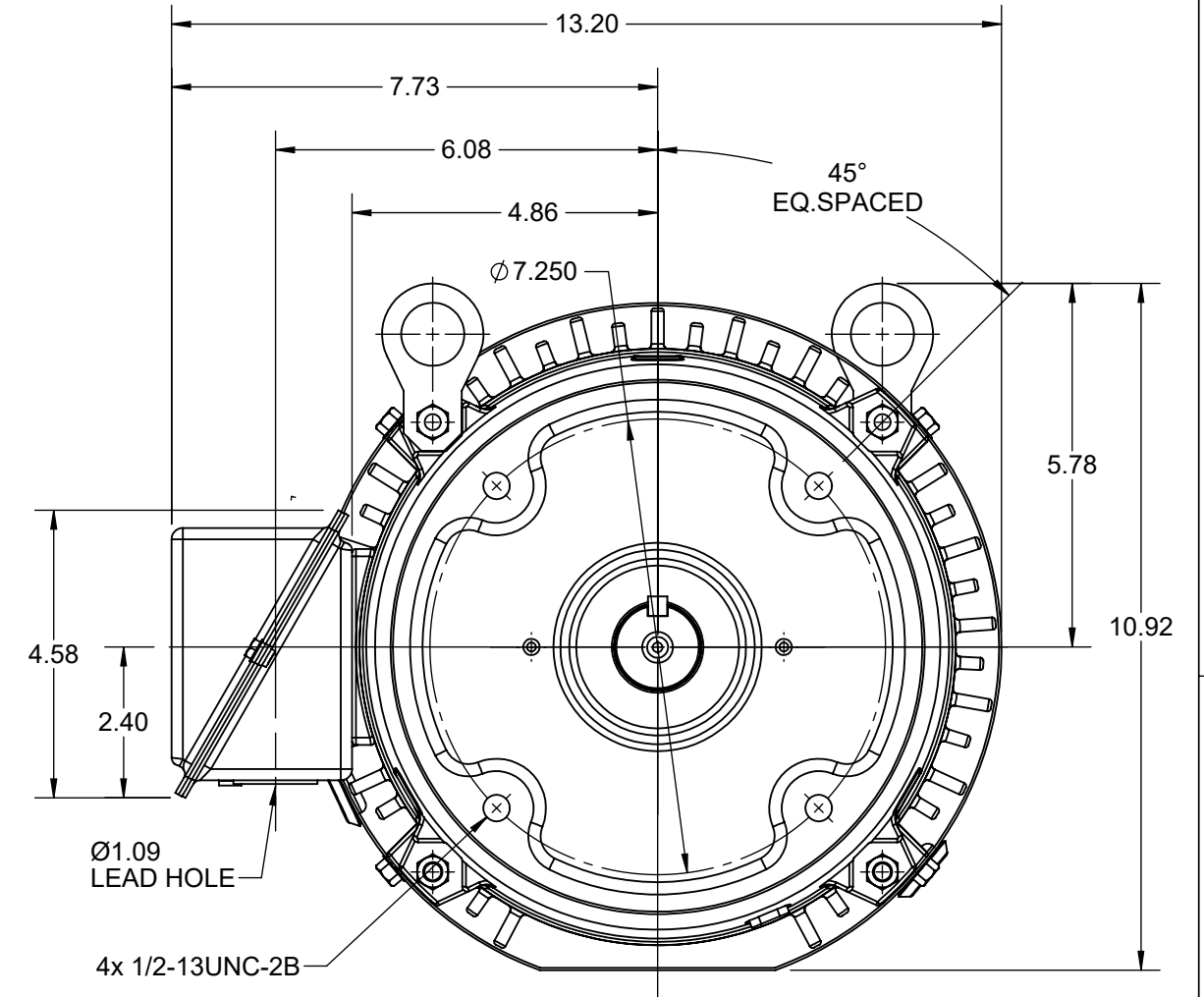
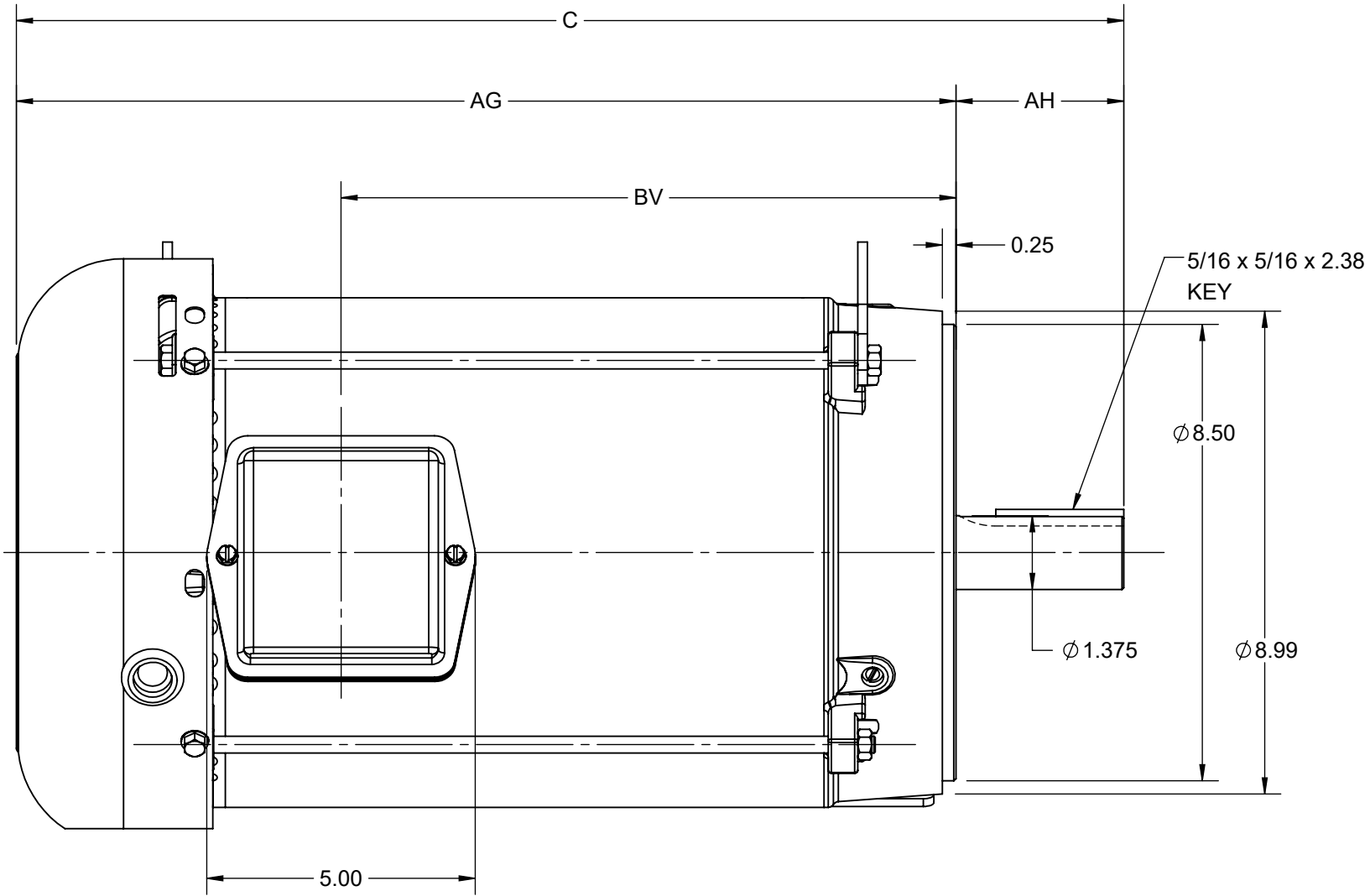

DRAWING REVISION D	REVISION BY BS	REV DATE/© DATE 09/05/2022
REQUEST NUMBER CR-0008840	APPROVED BY GNK	DATE 09/05/2022
REQUEST NUMBER DESCRIPTION FRAME AND CONDUIT BOX PART # UPDATED AS PER CR		
<small>COPYRIGHT (PER REVISION DATE) REGAL BELOIT AMERICA, INC. ALL RIGHTS RESERVED. PROPRIETARY AND CONFIDENTIAL INFORMATION - THIS DOCUMENT IS THE PROPERTY OF REGAL BELOIT AMERICA, INC. ("OWNER") AND CONTAINS OWNER'S PROPRIETARY INFORMATION. ANY PERSON, CORPORATION OR OTHER FIRM RECEIVING IT IS DEEMED, BY RECEIVING IT, TO AGREE THAT IT, AND/OR ANY PART OF IT, SHALL NOT BE DISCLOSED TO ANY PERSON, CORPORATION OR OTHER ENTITY, DUPLICATED, AND/OR USED, EXCEPT AS EXPRESSLY APPROVED IN WRITING IN ADVANCE BY OWNER. THIS DOCUMENT SHALL BE RETURNED TO OWNER UPON REQUEST. IT MAY BE SUBJECT TO CERTAIN RESTRICTIONS UNDER APPLICABLE EXPORT CONTROL LAWS AND REGULATIONS.</small>		

PRIMARY DIMENSIONS ARE INCH
mm DIMENSIONS IN [BRACKETS]
ARE FOR REFERENCE ONLY

DRAWN BY VY	Regal Rexnord Regal Beloit America, Inc.	
DATE 25/02/2016	DESCRIPTION	
APPROVED BY ZYH	OUTLINE	
DATE 25/02/2016	213/215TC FR NEMA TEFC RS	
REFERENCE	MATERIAL	PROCESS/FINISH
THIRD ANGLE PROJECTION	SIZE B	DRAWING NUMBER SS620712
		SHEET 1 OF 1



NO.	REVISION	BY & DATE	CHK	ANG	TOLERANCES UNLESS SPECIFIED		FINISH	DRAWN RM 11/20/1990				
					DEC.	INCHES						
5	CHG TO REGAL LOGO	SL 09/10/2015	AB					CHK ML 11/21/1990				
4	REVISED IEC NOTATIONS	MSG 11/15/2011	CMN	.X	±.1			APPD SAS 04/24/2003				
3	ADDED IEC NOTATIONS... (U1), (V1) ETC. MU95194	MSG 5/10/2010	MJS	.XX	±.02		TITLE CONNECTION DIAGRAM	SCALE 1=1				
2	ADDED THE OPTIONAL CORD CONNECTION MU46318	RDH 04/24/2003	DRS	.XXX	±.005		3Ø - DUAL VOLTAGE MOTOR	REF				
1	REDRAWN	RM 11/20/1990		.XXXX	±.0005		MAT'L.	FMF				
					±7'30"			PREV				
THIS DRAWING IN DESIGN AND DETAIL IS OUR PROPERTY AND MUST NOT BE USED EXCEPT IN CONNECTION WITH OUR WORK ALL RIGHTS OF DESIGN AND INVENTION ARE RESERVED THIS IS AN ELECTRONICALLY GENERATED DOCUMENT - DO NOT SCALE THIS PRINT							RFP	CAD FILE ee7308	SIZE A	DRAWING NO. EE7308	PAGE OF 5	REV. 5
							DIST WP					



P.O. BOX 8003
WAUSAU, WI 54401-8003
PH. 715-675-3311

DATA VOLTS: 460

CERTIFICATION DATA SHEET

CUSTOMER: _____ **CUSTOMER P.O. #:** _____
ORDER #: _____ **REFERENCE MODEL #:** 215TTFBD6005
CONN. DIAGRAM: EE7308 **CAT #:** GT13174
OUTLINE: SS620712-200 **CUSTOMER PART #:** _____
WINDING: HA31322023 NONE 1 **MOUNTING:** F1/F2 CAPABLE
SPEED: _____ **FAN:** 504205B

TYPICAL MOTOR PERFORMANCE DATA

HP	KW	SYNC RPM	FL RPM	FRAME	ENCLOSURE	TYPE	KVA CODE	DESIGN
15	11.2	3600	3530	215TC	TEFC	TFB	J	A

PH	HZ	VOLTS	AMPS	START TYPE	DUTY	INSL	S.F.	AMB	ELEV.
3	60/50	230/460#190/380	35/17.4&29/14.5	LINE OR INVERTER	CONT	F	1.15	40	3300

F.L. EFF	91.7	3/4 LD EFF	91.7	1/2 LD EFF	90.2	GTD EFF	ELECT. TYPE
F.L. PF	88.0	3/4 LD PF	84.0	1/2 LD PF	75.0	89.5	SQ CAGE INV RATED

F.L. TORQUE	LR AMPS @ 460 V	L.R. TORQUE	B.D. TORQUE	F.L. RISE (° C)
22.2 LB-FT	145	65.0 LB-FT 293%	80.0 LB-FT 360%	70

SOUND PRESSURE	SOUND	ROTOR WK²	MAX. LOAD WK²	SAFE STALL TIME	STARTS/HOUR	APROX.
60 dBA	69 dBA	0.60 LB-FT²	18 LB-FT²	10 SEC.	2	190 LB.

***** SUPPLEMENTAL INFORMATION *****

DE BRACKET TYPE	ODE BRACKET TYPE	MOUNT TYPE	MOTOR ORIENTATION	SEVERE DUTY	HAZARDOUS LOCATION	DRIP COVER	SCREENS	PAINT
C-FACE	STANDARD	ROUND	HORIZONTAL	NO	DIVISION 2 T2B	YES	NONE	BLUE (ENAMEL)

BEARINGS		GREASE	SHAFT TYPE	SPECIAL DE	SPECIAL ODE	SHAFT MATERIAL	FRAME MATERIAL
DE	ODE	POLYREX EM	T	NONE	NONE	1045 HOT ROLLED (C-204)	ROLLED STEEL
BALL	BALL						
6307	6206						

THERMOSTATS	PROTECTORS	WDG RTD's	BRG RTD's	THERMISTORS	CONTROL	SPACE HEATERS
NONE	NOT	NONE	NONE	NONE	FALSE	NA

R1 (ohms/ph)	R2 (ohms/ph)	X1 (ohms/ph)	X2 (ohms/ph)	Xm (ohms/ph)	VIBRATION (in/sec)	FLOAT
0.34	0.302	1.134	0.945	41.58	0.150	ODE

* N O T E S *	INVERTER TORQUE: CONSTANT 2:1/VARIABLE 10:1 INV. HP SPEED RANGE: NONE					
	ENCODER: NONE					
	NONE					
	NONE					
	NONE PPR					

PREPARED BY: _____ DATE: 7/28/2022	BRAKE: NONE					
	NONE NONE					
	FT-LB: NA					
	VOLTAGE: NONE HZ:					

FORM: 3531 REV_4 2/27/06

UL: NO LETTER - ME,WUXI TEFC BLUEWHALE CLASS 1 DIV. 2 UL LI

EC Declaration of Conformity

The undersigned representing
the manufacturer:

Regal Beloit America
100 East Randolph St.
Wausau, WI 54401

and the authorized representative
established within the Community:

Marathon Electric UK
6F Thistleton Road Ind. Estate
Market Overton
Oakham, Rutland LE15 7PP UK

are committed to providing customers with products that comply with applicable regulations and international protocols to which they are subject, including the requirements of the European Parliament Directive on the Harmonization of the laws relating to electrical equipment designed for use within certain voltage limits (2014/35/EU).

Regal Beloit America declares that the following product(s), to which this declaration relates, are in conformity with the relevant sections of the EC standards listed below.

This statement supersedes any statements previously issued pertaining to the product(s) listed below and is subject to change without notice.

Model No : 215TTFBD6005

(Model No. may contain prefix and/or suffix characters)

Catalog No : GT13174

Rework No : N/A

Directives :

Low Voltage Directive 2014/35/EU

Harmonized Standards Used :

EN 60034-1: 2010 (IEC 60034-1: 2010)

EN 60034-5: 2001/A1:2007 (IEC 60034-5: 2000/A1:2006)

Authorized Representative:



Michael A. Logsdon
Vice President, Technology

Authorized Representative in the Community:



Julian Clark
Marketing Engineer

Created on 09/01/2022

CE 22