

PRODUCT INFORMATION PACKET

Model No: 449TTGS16557

Catalog No: H504A

Explosion Proof Motor, 350 HP, 3 Ph, 60 Hz, 460 V, 1800 RPM, 449T Frame, EPFC



Regal and are trademarks of Regal Rexnord Corporation or one of its affiliated companies.
©2022 Regal Rexnord Corporation, All Rights Reserved. MC017097E

Nameplate Specifications

Output HP	350 Hp	Output KW	260.0 kW
Frequency	60 Hz	Voltage	460 V
Current	395.0 A	Speed	1785 rpm
Service Factor	1	Phase	3
Efficiency	96.2 %	Power Factor	86.5
Duty	Continuous	Insulation Class	F
Design Code	B	KVA Code	G
Frame	449T	Enclosure	Explosion Proof Fan cooled
Thermal Protection	Thermostat	Ambient Temperature	40 °C
Drive End Bearing Size	NU319	Opp Drive End Bearing Size	6318
UL	UL Listed; also, UL Certified for Canada	CSA	N
CE	N	IP Code	54
Hazardous Location	DIV 1 EXP PROOF CL I GR CD CL II GR FG T3B	Number of Speeds	1

Technical Specifications

Electrical Type	Squirrel Cage Inverter Rated	Starting Method	Part Wdg Start & Wye Start Delta Run Or Inverter
Poles	4	Rotation	Reversible
Resistance Main	.0075 Ohms	Mounting	Rigid Base
Motor Orientation	Horizontal	Drive End Bearing	Roller
Opp Drive End Bearing	Ball	Frame Material	Cast Iron
Shaft Type	T	Overall Length	51.85 in
Frame Length	28.75 in	Shaft Diameter	3.375 in
Shaft Extension	8.76 in	Assembly/Box Mounting	F1 ONLY
Inverter Load	CONSTANT 2:1		
Outline Drawing	B-SS515578-2875	Connection Drawing	A-EE7300CB

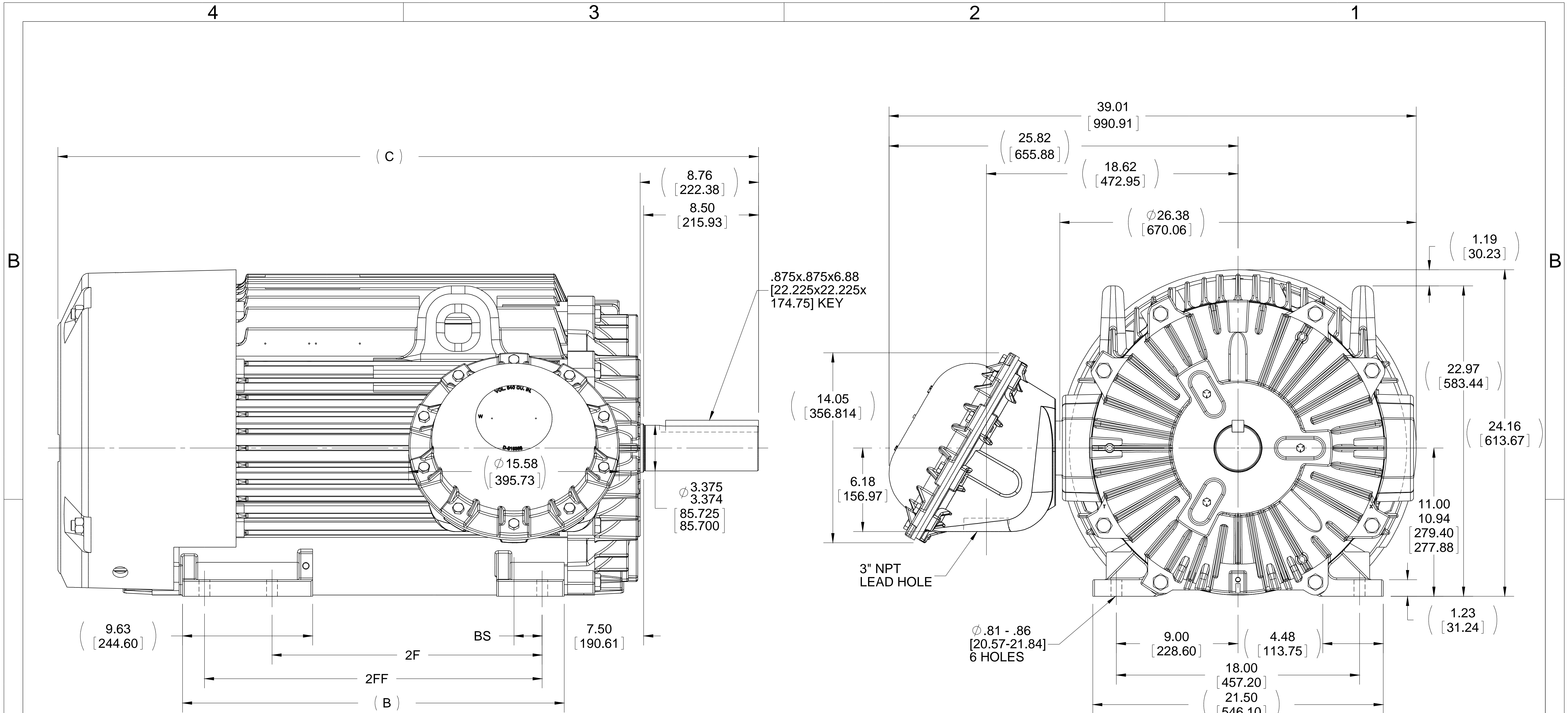

- NOTES:
 1. CONDUIT BOX CAN ONLY BE ROTATED CLOCKWISE UP TO 270° FROM ITS ORIGINAL POSITION.
 2. NAMEPLATES TO BE READ FROM CONDUIT BOX SIDE OF MOTOR.

DASH	FRAME	B	C	2F	2FF	BS
2875	447T	28.25 [717.55]	51.85 [1316.99]	20.00 [508.00]	-----	2.09 [53.09]
2875	449T	28.25 [717.55]	51.85 [1316.99]	-----	25.00 [635.00]	2.09 [53.09]

DRAWING REVISION C	REVISION BY AJW	DATE 03-31-2015
ECO ECO-0074730	APPROVED BY TDB	DATE 04-01-2015
ECO DESCRIPTION UPDATED TO CURRENT STANDARDS		
<small>COPYRIGHT REGAL BELOIT AMERICA, INC. ALL RIGHTS RESERVED. PROPRIETARY AND CONFIDENTIAL INFORMATION - THIS DOCUMENT IS THE PROPERTY OF REGAL BELOIT AMERICA, INC. ("OWNER") AND CONTAINS OWNER'S PROPRIETARY INFORMATION. ANY PERSON, CORPORATION OR OTHER FIRM RECEIVING IT IS DEEMED, BY RECEIVING IT, TO AGREE THAT IT, AND/OR ANY PART OF IT, SHALL NOT BE DISCLOSED TO ANY PERSON, CORPORATION OR OTHER ENTITY, DUPLICATED, AND/OR USED, EXCEPT AS EXPRESSLY APPROVED IN WRITING IN ADVANCE BY OWNER. THIS DOCUMENT SHALL BE RETURNED TO OWNER UPON REQUEST. IT MAY BE SUBJECT TO CERTAIN RESTRICTIONS UNDER APPLICABLE EXPORT CONTROL LAWS AND REGULATIONS.</small>		

TOLERANCES UNLESS OTHERWISE SPECIFIED:

DEC.	INCH	mm	ANGLE
.X	±0.1	[±2.5]	±7' 30"
.XX	±0.03	[±0.76]	
.XXX	±0.005	[±0.127]	
.XXXX	±0.0005	[±0.0127]	

REMOVE BURRS & BREAK SHARP EDGES: .003/.015 [0.076/.381] X 45°
 CORNER FILLETS: R.02 [51]
 MACHINED SURFACES: 200 INCH/mm 5.1
 mm SHOWN IN [BRACKETS]

DRAWN BY SMC
DATE 04-15-1996
APPROVED BY JPN
DATE 04-19-1996
REFERENCE
THIRD ANGLE PROJECTION

REGAL ™ Regal Beloit America, Inc.	
DESCRIPTION OUTLINE 447/449T FR. -EXP. PR. - STD.	
MATERIAL	PROCESS/FINISH
SIZE B	DRAWING NUMBER SS515578
	SHEET 1 OF 1

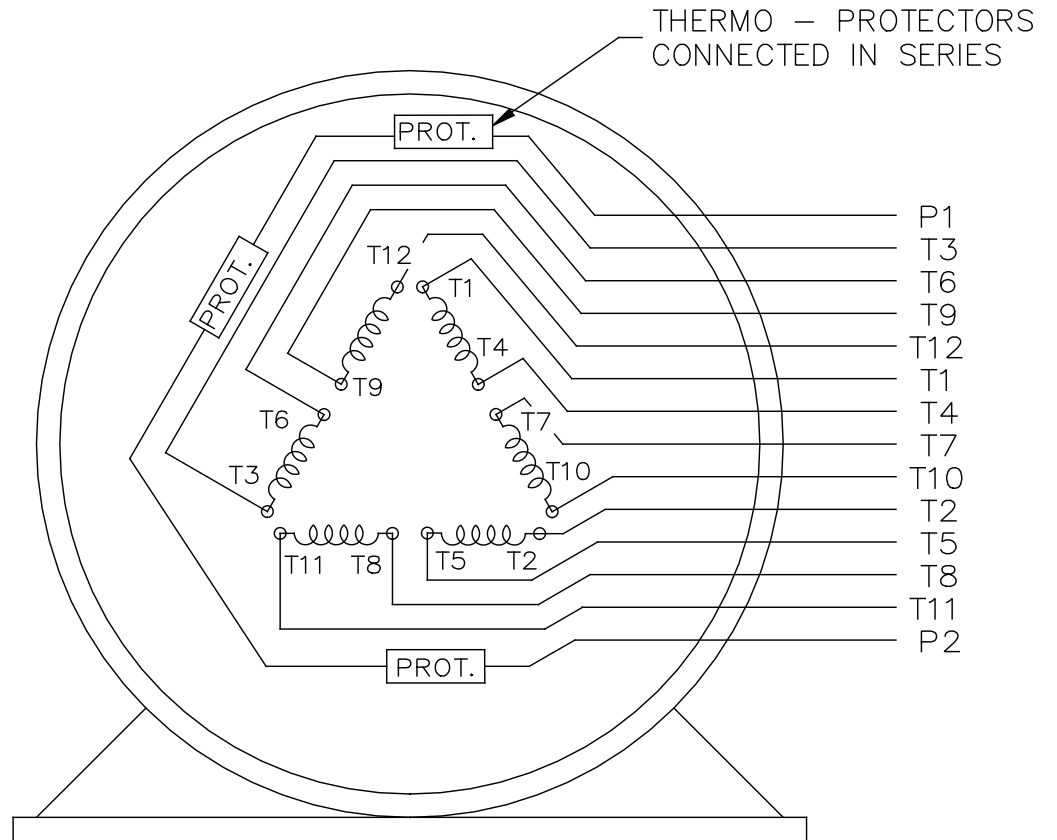
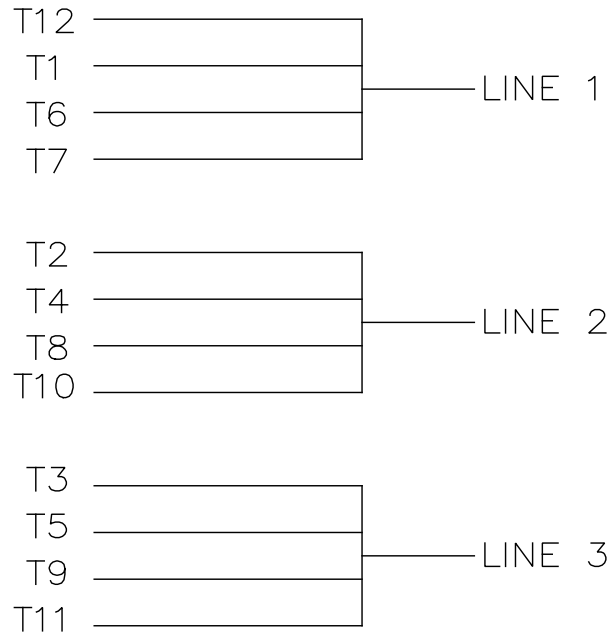

VIEW OF TERMINAL END

				TOLERANCES UNLESS SPECIFIED		REGAL REGAL-BELOIT CORPORATION	DRAWN KL 02-27-2003				
				DEC.	INCHES		CHK GFH 03-03-2003				
				.X	± -		APPD JES 03-03-2003				
				.XX	± -	TITLE CONNECTION DIAGRAM - EXTERNAL	SCALE 1=1				
				.XXX	± -	12 LEAD SINGLE VOLTAGE	REF				
A	CHANGED TO REGAL TITLEBLOCK ECO-0108299	WGJ 08-18-2016	EMH	.XXXX	± -	MAT'L.	FMF				
NO.	REVISION	BY & DATE	CHK	ANG	± -	FINISH	PREV				
THIS DRAWING IN DESIGN AND DETAIL IS OUR PROPERTY AND MUST NOT BE USED EXCEPT IN CONNECTION WITH OUR WORK ALL RIGHTS OF DESIGN AND INVENTION ARE RESERVED THIS IS AN ELECTRONICALLY GENERATED DOCUMENT - DO NOT SCALE THIS PRINT						RFP	CAD FILE EE7300CB	SIZE A	DRAWING NO. EE7300CB	PAGE OF	REV.
						DIST					

CERTIFICATION DATA SHEET

Model#: 449TTGS16557 AA **WINDING#:** T4494123 NONE 1
CONN. DIAGRAM: A-EE7300CB **ASSEMBLY:** F1 ONLY
OUTLINE: B-SS515578-2875

TYPICAL MOTOR PERFORMANCE DATA

HP	KW	SYNC. RPM	F.L. RPM	FRAME	ENCLOSURE	KVA CODE	DESIGN
350	260	1800	1785	447/449T	EPFC	G	B

PH	Hz	VOLTS	FL AMPS	START TYPE	DUTY	INSL	S.F	AMB°C	ELEVATION
3	60	460	395	PWS & YDRUN OR INV	CONTINUOUS	F1	1.0	40	3300

FULL LOAD EFF: 96.2	3/4 LOAD EFF: 96.2	1/2 LOAD EFF: 95.4	GTD. EFF	ELEC. TYPE	NO LOAD AMPS
FULL LOAD PF: 86.5	3/4 LOAD PF: 84	1/2 LOAD PF: 77.5	95.8	SQ CAGE INV RATED	115

F.L. TORQUE	LOCKED ROTOR AMPS	L.R. TORQUE	B.D. TORQUE	F.L. RISE°C
1030 LB-FT	2550	2075 LB-FT 201	2400 LB-FT 233	80

SOUND PRESSURE @ 3 FT.	SOUND POWER	ROTOR WK^2	MAX. WK^2	SAFE STALL TIME	STARTS /HOUR	APPROX. MOTOR WGT
85 dBA	95 dBA	98 LB-FT^2	2900 LB-FT^2	25 SEC.	1	3100 LBS.

***** SUPPLEMENTAL INFORMATION *****

DE BRACKET TYPE	ODE BRACKET TYPE	MOUNT TYPE	ORIENTATION	SEVERE DUTY	HAZARDOUS LOCATION	DRIP COVER	SCREENS	PAINT
STANDARD	STANDARD	RIGID	HORIZONTAL	PREMIUM SEVERE DUTY	EXP PROOF CL I GR C&D CL II GR F&G T3B	FALSE	NONE	BLUE (EPOXY)

BEARINGS		GREASE	SHAFT TYPE	SPECIAL DE	SPECIAL ODE	SHAFT MATERIAL	FRAME MATERIAL
DE	OPE						
ROLLER	BALL	POLYREX EM	T	NONE	NONE	1045 HOT ROLLED (C-204)	CAST IRON
NU319	6318						

THERMO-PROTECTORS				THERMISTORS	CONTROL	SPACE /n HEATERS
THERMOSTATS	PROTECTORS	WDG RTDs	BRG RTDs			
TSTATS (N/C)	NOT	NONE	NONE	NONE	FALSE	NONE VOLTS

If Inverter equals NONE, contact factory for further information

*
N
O
T
E
S
*

INVERTER TORQUE: CONSTANT 2:1
INV. HP SPEED RANGE: 1.5 X BASE SPEED
ENCODER: NONE
NONE NONE
NONE NONE PPR
BRAKE: NONE NONE
NONE P/N NONE
NONE NONE
NONE FT-LB NONE V NONE Hz

DATE: 06/21/2017 07:28:17 AM
 FORM 3531 REV.3 02/07/99
 ** Subject to change without notice.

Data Sheet

Date: 6/19/2017

449TTGS16557

Customer: _____

Attention: _____

Submitted by: FAREEDA DUDEKULA



Submittal

Data @ 460 V

Motor Load Data

Load	0%	25%	50%	75%	100%	115%	125%	LR
Current (Amps)	115	148	218	304	395	450	490	2,550
Torque (ft-lb)	0.00	256	512	770	1,030	1,185	1,290	2,075
RPM	1800	1796	1794	1790	1785	1,782	1780	0
Efficiency (%)		92.4	95.4	96.2	96.2	95.8	95.4	
P.F. (%)	5.5	59.0	77.5	84.0	86.5	86.5	86.5	31.0

Motor Speed Data

	LR	Pull-Up	BD	Rated	Idle
Speed (RPM)	0	900	1725	1785	1800
Current (Amps)	2,550	2,250	1,350	395	115
Torque (ft-lb)	2,075	1,950	2,400	1,030	0.00

Information Block

HP	350.0			
Sync. RPM	1800			
Frame	449			
Enclosure	TEFC			
Construction	TFN			
Voltage	460 V			
Frequency	60 Hz			
Design	A			
LR Code letter	G			
Service Factor	1.15			
Temp Rise @ FL	80 °C			
Duty	CONT			
Ambient	40 °C			
Elevation	1,000 feet			
Rotor/Shaft wk ²	98.0 Lb-Ft ²			
Ref Wdg	T4494123 NONE			
Sound Pressure @ 1M	85 dBA			
VFD Rating	CONSTANT 2:1			
Outline Dwg	B-SS515578-2875			
Conn. Diag	A-EE7300CB			
Additional Specifications:				
0				
0				
EQUIV CKT (OHMS / PHASE)				
R1	R2	X1	X2	Xm
0.0070	0.0050	0.0660	0.1000	2.3110

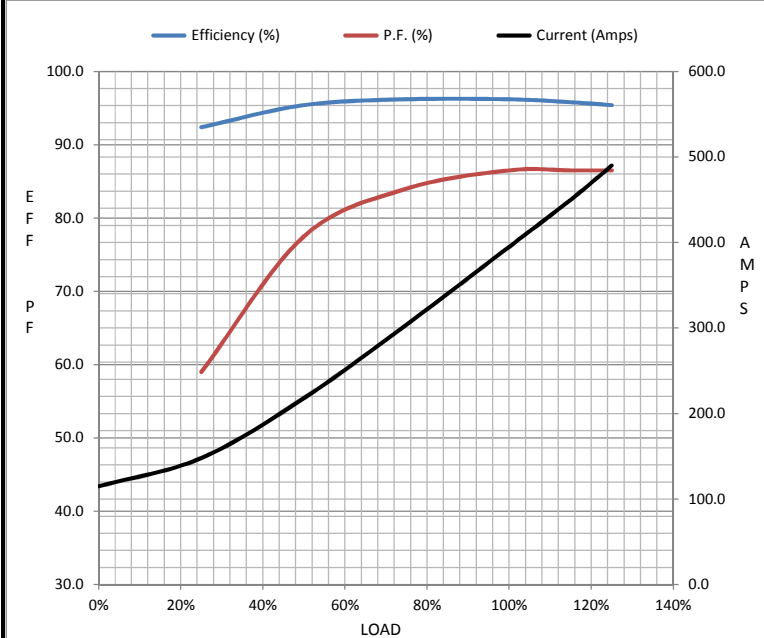

Speed -Torque Curve

