

DATE
APRIL 27, 2003
CATALOG NO.
HB0152

OUTLINE DIMENSIONS
3-PHASE INDUCTION MOTOR

MOTOR TYPE:
AEHH8B
FRAME NO. 254T

Pole	HP	KW	Hz	VOLT	Syn.Speed RPM
2	15	11	60	460	3600

Ins	Rating	Dimension in	Approx Weight	Bearings
F	CONT.	inches	297 lbs.	DE: 6309ZC35C NDE: 6307ZC35C

Totally Enclosed Fan-Cooled Type. Squirrel-cage Rotor.

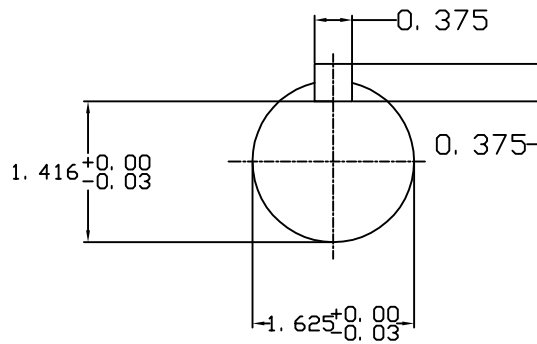
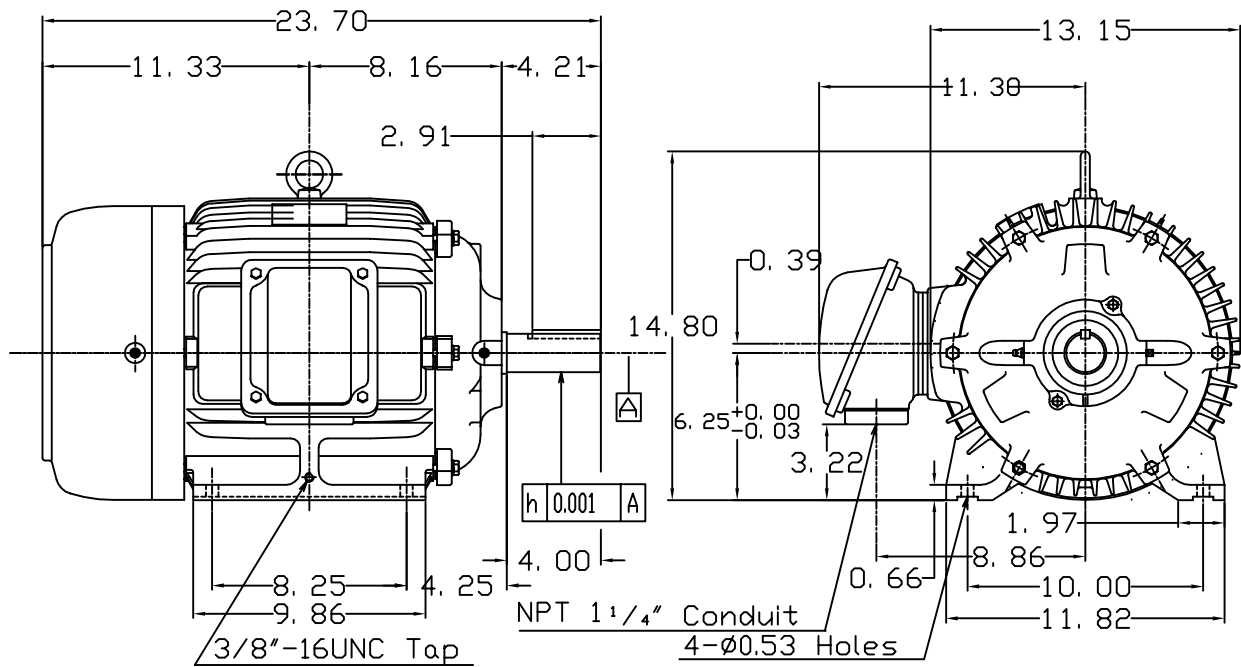

DWN.	簡學民	12-04-98
CHKD.	高金星	12-10-98
APPD.	黃友伯	12-10-98

TEC Westinghouse

DWG NO.
31049HB625061

TECO Westinghouse

ISSUED 8/28/2014	PERFORMANCE DATA 3-PHASE INDUCTION MOTOR	ENCLOSURE TEFC
TYPE AEHH8B		CATALOG# HB0152

NAMEPLATE INFORMATION

OUTPUT		POLE	FRAME SIZE	VOLTAGE	HZ	RATED AMBIENT	INS. CLASS	NEMA DESIGN	TIME RATING	SERVICE FACTOR
HP	KW									
15	11.2	2	254T	460	60	50°C	F	B	CONT.	1.15

VARIABLE FREQUENCY DRIVE SERVICE

VARIABLE TORQUE				OHMS/PHASE EQUIVALENT WYE CIRCUIT (AT RATED OPERATING TEMPERATURE 25°C)				
HZ	HP	RPM	TORQUE (lb-ft)	R1	R2	X1	X2	X _m
3~60	0.0019~15	180~3600	0.055~22.34	0.3144	0.3797	1.1823	1.8437	70.172

CONSTANT TORQUE				CONSTANT HORSEPOWER			
HZ	HP	RPM	TORQUE (lb-ft)	HZ	HP	RPM	TORQUE (lb-ft)
6~60	1.5~15	360~3600	22.34	60~90	15	3600~5400	22.34~14.89

TYPICAL PERFORMANCE

FULL LOAD RPM	EFFICIENCY				POWER FACTOR			SOUND PRESSURE LEVEL @ 3 FT Db(A)
	FULL LOAD		3/4 LOAD %	1/2 LOAD %	FULL LOAD %	3/4 LOAD %	1/2 LOAD %	
	MIN.%	NOM.%						
3525	91	92.4	92.4	91.7	91.5	90.5	86	73

CURRENTS			NEMA KVA CODE LETTER	SAFE STALL TIME IN SECONDS	
NO LOAD	FULL LOAD	LOCKED ROTOR		COLD	HOT
AT 460 VOLT	AT 460 VOLT	AT 460 VOLT			
3.72	16.60	116	G	17	12

TORQUE				INERTIA			ACCEL TIME (DOL)		ALLOWABLE STARTS PER HOUR	
FULL LOAD (lb-ft)	LOCKED ROTOR %FLT	PULL UP %FLT	BREAK DOWN %FLT	ROTOR WR ² (lb-ft ²)	NEMA LOAD WK ² (lb-ft ²)	MAX ALLOWABLE WK ² (lb-ft ²)	NEMA LOAD WK ² Sec	MAX ALLOWABLE WK ² Sec	COLD	HOT
22.34	210	180	270	1.088	16	41	3.95	9.73	2	1

APPROVED:	M. PRATER	DRAWING NO.	31057HB0152	REVISION:	1
-----------	------------------	-------------	--------------------	-----------	----------

DATE:
June 27, 2005

CONNECTION DIAGRAM

CATALOG NO.:
HB0152



SCHEMATIC - Δ CONNECTION

ACROSS THE LINE CONNECTION



460 VOLT CONNECTION