

TYPE	OUTPUT		POLE	TIME RATING	VOLTAGE V	Hz	SYN.SPEED R.P.M
	HP.	kW.					
AEHH8B	200	149.2	2	CONT.	460	60	3600

TOTALLY ENCLOSED FAN-COOLED TYPE. SQUIRREL-CAGE ROTOR

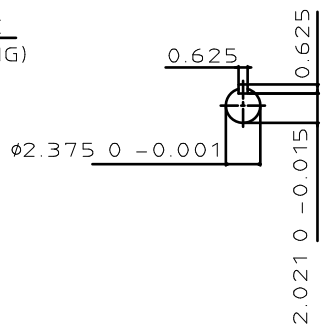
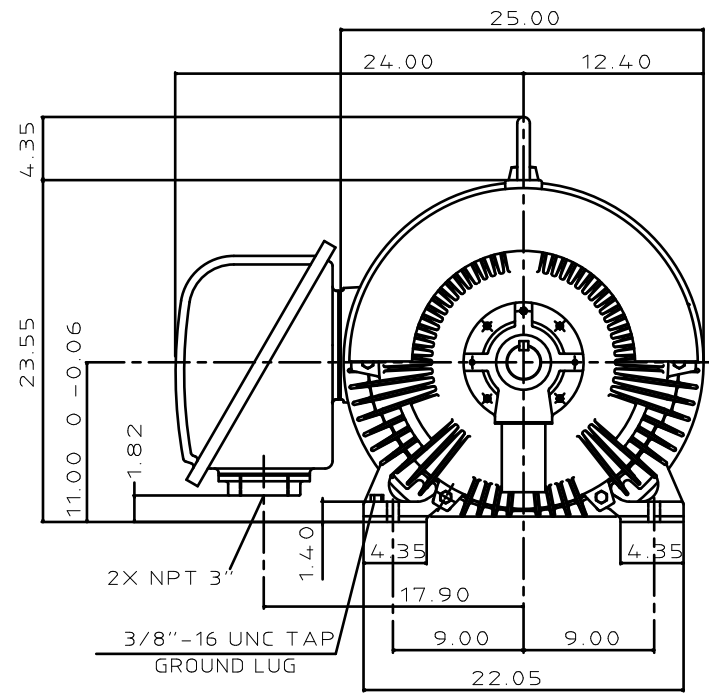
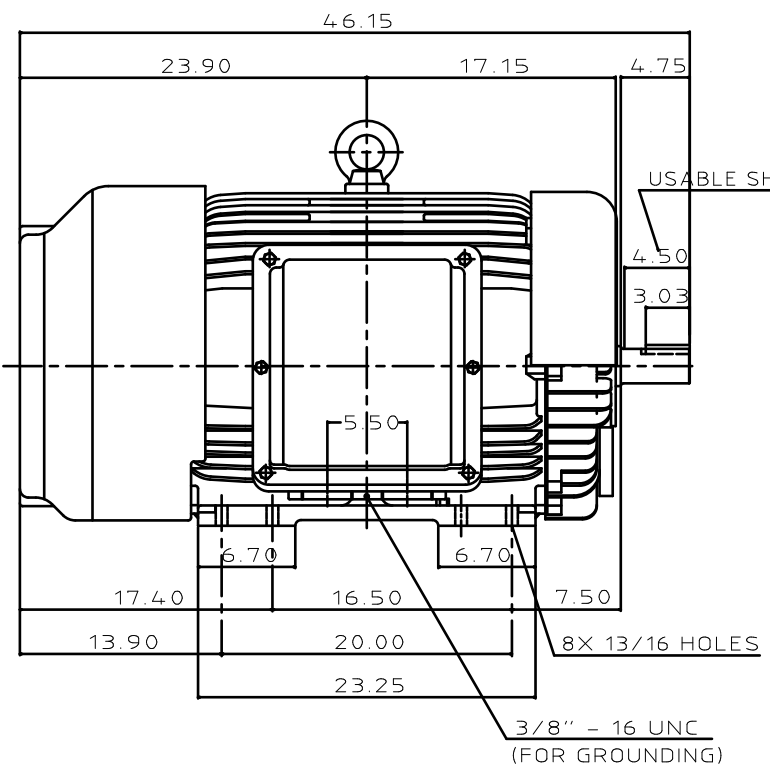

- NOTE:
1. DIMENSIONS IN INCH
 2. FRAME NO. 447TS
 3. F CLASS INSULATION, S.F.1.15
 4. FOR DIRECT FLEXIBLE COUPLING
 5. ENCLOSURE: IP65
 6. BEARING SIZE: DRIVE END: 6314C3
NON-DRIVE END: 6314C3
 7. APPROX. WEIGHT: 1900 LBS
 8. INPRO SEAL ON BOTH ENDS.
 9. NON-SPARKING FAN.
 10. NOISE BELOW 83 DBA AT 1 METER AT NO LOAD.
 11. VIBRATION VERTICAL/HORIZONTAL BELOW 0.08 IN/SEC
AXIAL BELOW 0.06 IN/SEC.

TW-56BC

DATE	12-12-17	OUTLINE DIMENSIONS
CATALOG #	HB2002	3-PHASE INDUCTION MOTOR
DWG NO.	3A040Y701	REV: 02

DWN	T.H.Pan	FEB*18 2005
CHKD	H.HUANG	FEB*18 2005
APPD	C.WANG	FEB*18 2005



TECO Westinghouse

ISSUED 8/28/2014	PERFORMANCE DATA 3-PHASE INDUCTION MOTOR	ENCLOSURE TEFC
TYPE AEHH8B		CATALOG# HB2002

NAMEPLATE INFORMATION

OUTPUT		POLE	FRAME SIZE	VOLTAGE	HZ	RATED AMBIENT	INS. CLASS	NEMA DESIGN	TIME RATING	SERVICE FACTOR
HP	KW									
200	149	2	447TS	460	60	50°C	F	B	CONT.	1.15

VARIABLE FREQUENCY DRIVE SERVICE

VARIABLE TORQUE				OHMS/PHASE EQUIVALENT WYE CIRCUIT (AT RATED OPERATING TEMPERATURE 25°C)				
HZ	HP	RPM	TORQUE (lb-ft)	R1	R2	X1	X2	X _m
3~60	0.025~200	180~3600	0.729~293	0.0246	0.02	0.209	0.402	10.8

CONSTANT TORQUE				CONSTANT HORSEPOWER			
HZ	HP	RPM	TORQUE (lb-ft)	HZ	HP	RPM	TORQUE (lb-ft)
6~60	20~200	360~3600	293	60	200	3600	293

TYPICAL PERFORMANCE

FULL LOAD RPM	EFFICIENCY				POWER FACTOR			SOUND PRESSURE LEVEL @ 3 FT Db(A)
	FULL LOAD		3/4 LOAD %	1/2 LOAD %	FULL LOAD %	3/4 LOAD %	1/2 LOAD %	
	MIN.%	NOM.%						
3572	94.5	95.4	95	94.1	89	85	81	83

CURRENTS			NEMA KVA CODE LETTER	SAFE STALL TIME IN SECONDS	
NO LOAD	FULL LOAD	LOCKED ROTOR		COLD	HOT
AT 460 VOLT	AT 460 VOLT	AT 460 VOLT			
44.6	221.00	1450	G	24	17

TORQUE				INERTIA			ACCEL TIME (DOL)		ALLOWABLE STARTS PER HOUR	
FULL LOAD (lb-ft)	LOCKED ROTOR %FLT	PULL UP %FLT	BREAK DOWN %FLT	ROTOR WR ² (lb-ft ²)	NEMA LOAD WK ² (lb-ft ²)	MAX ALLOWABLE WK ² (lb-ft ²)	NEMA LOAD WK ² Sec	MAX ALLOWABLE WK ² Sec	COLD	HOT
294.00	104	83	210	32	172	172	5.15	5.15	2	1

APPROVED:	M. PRATER	DRAWING NO.	31057HB2002	REVISION:	1
-----------	------------------	-------------	--------------------	-----------	----------

DATE:
June 27, 2005

CONNECTION DIAGRAM

CATALOG NO.:
HB2002



SCHEMATIC - Δ CONNECTION

ACROSS THE LINE CONNECTION



460 VOLT CONNECTION