

DATE
APRIL 26, 2004
CATALOG NO.
HB7/54

OUTLINE DIMENSIONS
3-PHASE INDUCTION MOTOR

MOTOR TYPE:
AEHH8B
FRAME NO. 213T

Pole	HP	KW	Hz	VOLT	Syn.Speed RPM
4	7.5	5.6	60	460	1800

Ins	Rating	Dimension in	Approx Weight	Bearings
F	CONT.	inches	167 lbs.	DE: 6308ZC35C NDE: 6306ZC35C

Totally Enclosed Fan-Cooled Type.Squirrel-Cage Rotor.

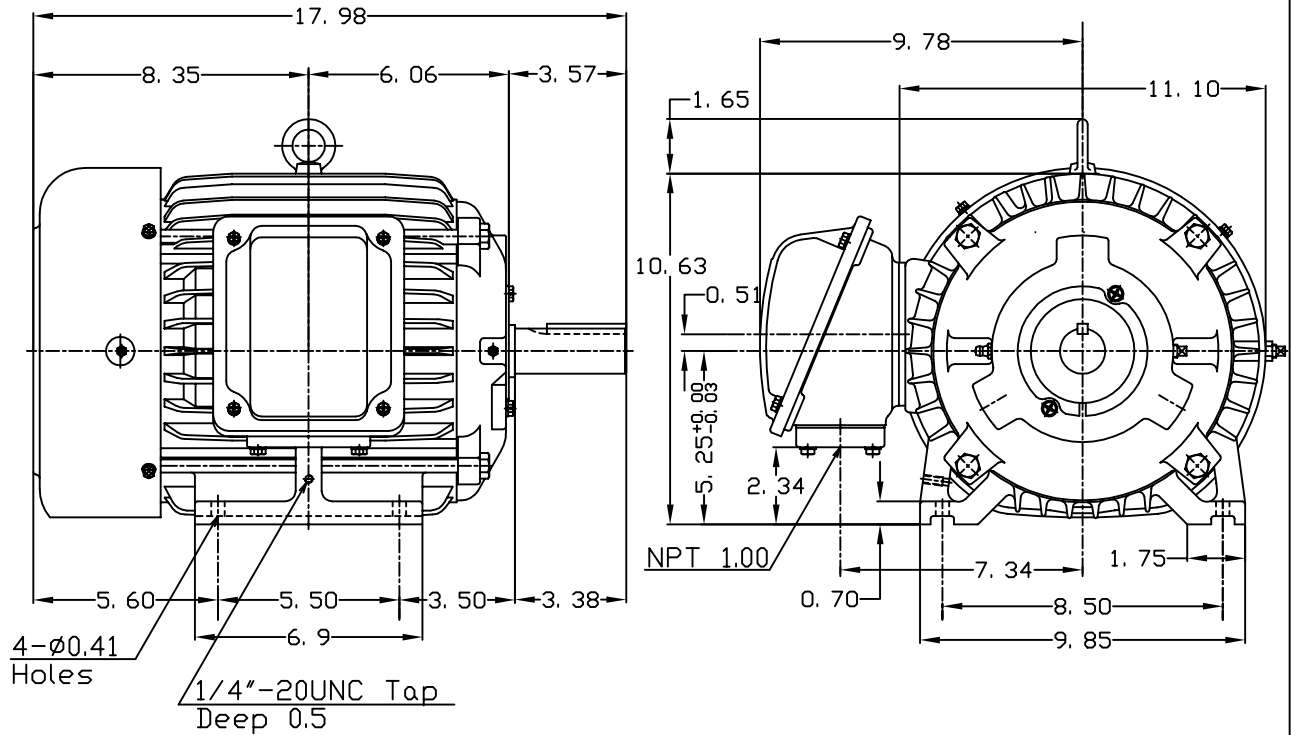

4- ϕ 0.41
Holes

1/4"-20UNC Tap
Deep 0.5

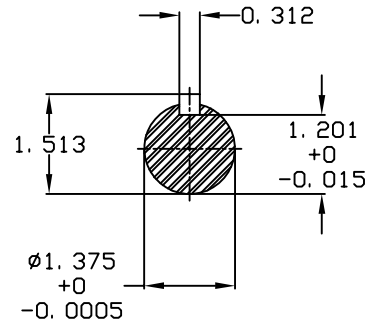
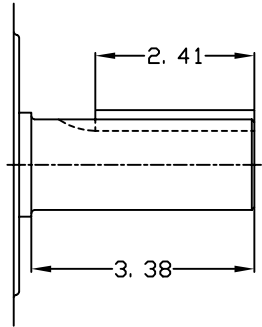

DWN.	胡峰誠	11-12-98
CHKD.	羅清水	11-23-98
APPD.	黃友伯	11-23-98



DWG NO.
31049HB893002

TECO Westinghouse

ISSUED 8/28/2014	PERFORMANCE DATA 3-PHASE INDUCTION MOTOR	ENCLOSURE TEFC
TYPE AEHH8B		CATALOG# HB7/54

NAMEPLATE INFORMATION

OUTPUT		POLE	FRAME SIZE	VOLTAGE	HZ	RATED AMBIENT	INS. CLASS	NEMA DESIGN	TIME RATING	SERVICE FACTOR
HP	KW									
7.5	5.6	4	213T	460	60	50°C	F	B	CONT.	1.15

VARIABLE FREQUENCY DRIVE SERVICE

VARIABLE TORQUE				OHMS/PHASE EQUIVALENT WYE CIRCUIT (AT RATED OPERATING TEMPERATURE 25°C)				
HZ	HP	RPM	TORQUE (lb-ft)	R1	R2	X1	X2	X _m
3~60	0.001~7.5	90~1800	0.058~22.44	0.7575	0.9336	2.5226	3.3729	97.772

CONSTANT TORQUE				CONSTANT HORSEPOWER			
HZ	HP	RPM	TORQUE (lb-ft)	HZ	HP	RPM	TORQUE (lb-ft)
6~60	.75~7.5	180~1800	22.44	60~120	7.5	1800~3600	22.44~11.22

TYPICAL PERFORMANCE

FULL LOAD RPM	EFFICIENCY				POWER FACTOR			SOUND PRESSURE LEVEL @ 3 FT Db(A)
	FULL LOAD		3/4 LOAD %	1/2 LOAD %	FULL LOAD %	3/4 LOAD %	1/2 LOAD %	
	MIN.%	NOM.%						
1755	90.2	91.7	91	89.5	86.5	82	72	60

CURRENTS			NEMA KVA CODE LETTER	SAFE STALL TIME IN SECONDS	
NO LOAD	FULL LOAD	LOCKED ROTOR		COLD	HOT
AT 460 VOLT	AT 460 VOLT	AT 460 VOLT			
2.77	8.85	64	H	29	20

TORQUE				INERTIA			ACCEL TIME (DOL)		ALLOWABLE STARTS PER HOUR	
FULL LOAD (lb-ft)	LOCKED ROTOR %FLT	PULL UP %FLT	BREAK DOWN %FLT	ROTOR WR ² (lb-ft ²)	NEMA LOAD WK ² (lb-ft ²)	MAX ALLOWABLE WK ² (lb-ft ²)	NEMA LOAD WK ² Sec	MAX ALLOWABLE WK ² Sec	COLD	HOT
22.44	250	155	270	0.848	39	110	4.31	11.98	2	1

APPROVED:	M. PRATER	DRAWING NO.	31057HB7/54	REVISION:	1
-----------	------------------	-------------	--------------------	-----------	----------

DATE:
June 27, 2005

CONNECTION DIAGRAM

CATALOG NO.:
HB7/54



SCHEMATIC - Δ CONNECTION

ACROSS THE LINE CONNECTION



460 VOLT CONNECTION