

DATE
January 21, 2009
CAT. #: HBV0502C

OUTLINE DIMENSIONS
3-PHASE INDUCTION MOTOR

MOTOR TYPE:
AEUH8B-DC
FRAME NO. 326TSC

Pole	HP	kW	Hz	VOLT	Syn.Speed r/min(rpm)
2	50	37.3	60	460	3600

Ins	Rating	Dimension in	Approx Weight	Bearings
F	CONT.	inches	715 LBS	DE: 6312ZC3 NDE: 6212ZC3

Totally Enclosed Fan-cooled Vertical Type.Squirrel-cage Rotor.

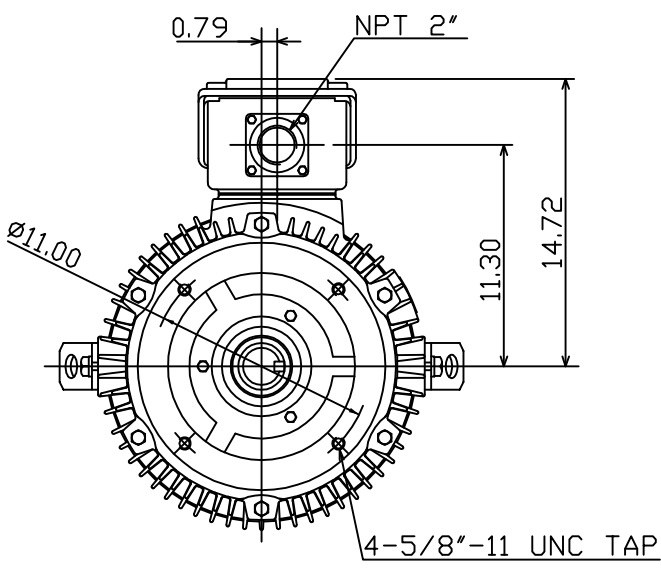
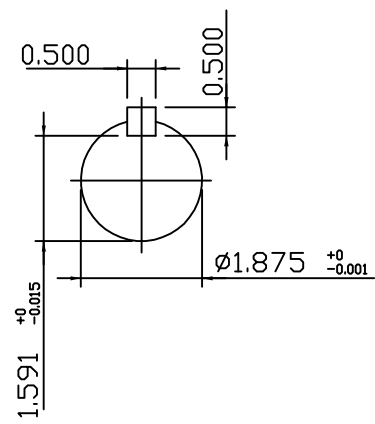
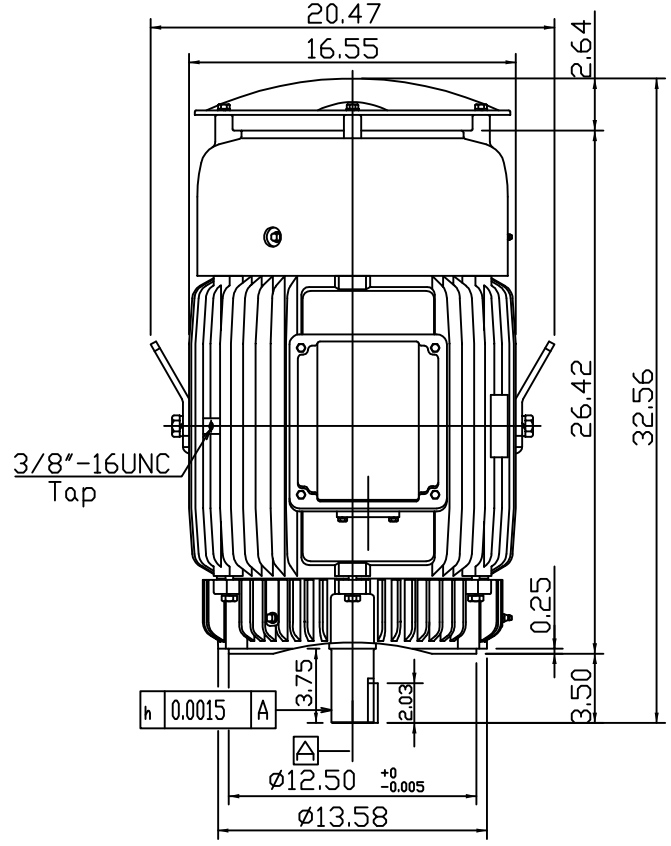

- Note:
1. C/W Inpro/Seal In Both End Brackets.
 2. Motor Vibration:10μ

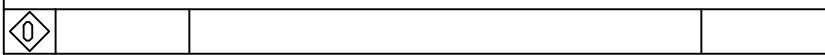

DWN.	???????	01 01 09
CHKD.	???????	01 02 09
APPD.	???????	01 02 09



DWG NO.
31057H417220

TECO Westinghouse

ISSUED 8/29/2014	PERFORMANCE DATA 3-PHASE INDUCTION MOTOR	ENCLOSURE TEFC
TYPE AEUH8BDC		CATALOG# HBV0502C

NAMEPLATE INFORMATION

OUTPUT		POLE	FRAME SIZE	VOLTAGE	HZ	RATED AMBIENT	INS. CLASS	NEMA DESIGN	TIME RATING	SERVICE FACTOR
HP	KW									
50	37.3	2	326TSC	460	60	50°C	F	B	CONT.	1.15

VARIABLE FREQUENCY DRIVE SERVICE

VARIABLE TORQUE				OHMS/PHASE EQUIVALENT WYE CIRCUIT (AT RATED OPERATING TEMPERATURE 25°C)				
HZ	HP	RPM	TORQUE (lb-ft)	R1	R2	X1	X2	X _m
3~60	0.0063~50	180~3600	0.184~73.95	0.0517	0.0927	0.3921	0.6956	25.594

CONSTANT TORQUE				CONSTANT HORSEPOWER			
HZ	HP	RPM	TORQUE (lb-ft)	HZ	HP	RPM	TORQUE (lb-ft)
6~60	5~50	360~3600	73.95	60~75	50	3600~4500	73.95~59.16

TYPICAL PERFORMANCE

FULL LOAD RPM	EFFICIENCY				POWER FACTOR			SOUND PRESSURE LEVEL @ 3 FT Db(A)
	FULL LOAD		3/4 LOAD %	1/2 LOAD %	FULL LOAD %	3/4 LOAD %	1/2 LOAD %	
	MIN.%	NOM.%						
3550	93	94.1	94.5	94.5	91	90	86.5	78

CURRENTS			NEMA KVA CODE LETTER	SAFE STALL TIME IN SECONDS	
NO LOAD	FULL LOAD	LOCKED ROTOR		COLD	HOT
AT 460 VOLT	AT 460 VOLT	AT 460 VOLT			
10.2	54.70	363	G	17	12

TORQUE				INERTIA			ACCEL TIME (DOL)		ALLOWABLE STARTS PER HOUR	
FULL LOAD (lb-ft)	LOCKED ROTOR %FLT	PULL UP %FLT	BREAK DOWN %FLT	ROTOR WR ² (lb-ft ²)	NEMA LOAD WK ² (lb-ft ²)	MAX ALLOWABLE WK ² (lb-ft ²)	NEMA LOAD WK ² Sec	MAX ALLOWABLE WK ² Sec	COLD	HOT
73.95	150	130	240	4.488	49		4.47	0.37	2	1

APPROVED:	M. PRATER	DRAWING NO.	31057HBV0502C	REVISION:	1
-----------	------------------	-------------	----------------------	-----------	----------

DATE:
June 27, 2005

CONNECTION DIAGRAM

CATALOG NO.:
HBV0502C



SCHEMATIC - Δ CONNECTION

ACROSS THE LINE CONNECTION



460 VOLT CONNECTION