

DATE
Sept. 12, 2005

CAT. #: HH0302

OUTLINE DIMENSIONS

3-PHASE INDUCTION MOTOR

MOTOR TYPE:
AEHH

FRAME NO. 286TS

Pole	HP	kW	Hz	VOLT	Syn. Speed r/min(rpm)
2	30	22.4	60	460	3600

Ins	Rating	Dimension in	Approx Weight	Bearings
F	CONT.	inches	444 lbs.	DE: 6311ZC3 NDE: 6310ZC3

Totally Enclosed Fan Cooled Type. Squirrel-cage Rotor.

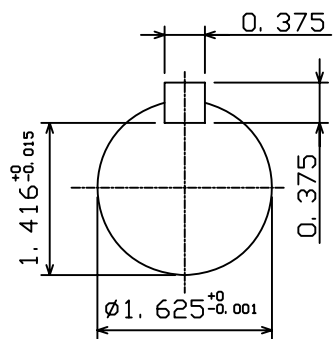
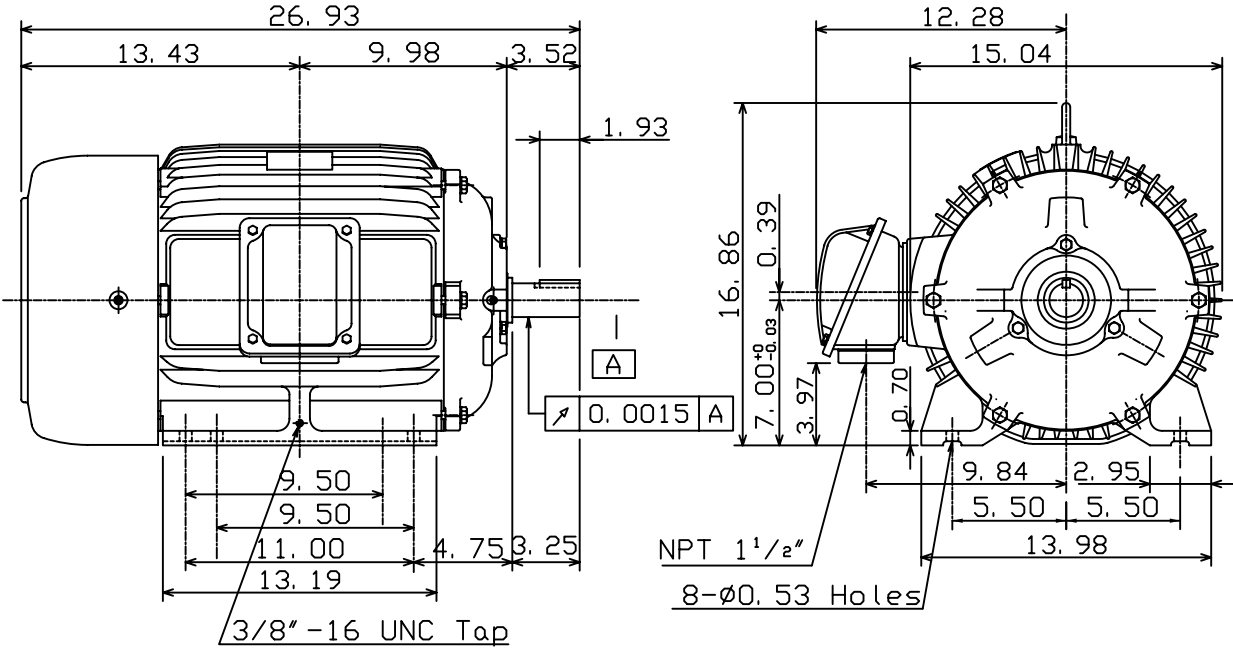

◇		
---	--	--

DWN.	K. L. KUO	01-13-05
CHKD.	C. H. KAO	02-02-05
APPD.	M. C. TSAI	02-02-05



DWG NO.
31049M628430

TECO Westinghouse

ISSUED 8/29/2014	PERFORMANCE DATA 3-PHASE INDUCTION MOTOR	ENCLOSURE TEFC
TYPE AEHH		CATALOG# HH0302

NAMEPLATE INFORMATION

OUTPUT		POLE	FRAME SIZE	VOLTAGE	HZ	RATED AMBIENT	INS. CLASS	NEMA DESIGN	TIME RATING	SERVICE FACTOR
HP	KW									
30	22.4	2	286TS	460	60	40°C	F	B	CONT.	1.15

VARIABLE FREQUENCY DRIVE SERVICE

VARIABLE TORQUE				OHMS/PHASE EQUIVALENT WYE CIRCUIT (AT RATED OPERATING TEMPERATURE 25°C)				
HZ	HP	RPM	TORQUE (lb-ft)	R1	R2	X1	X2	X _m
3~60	0.0038~30	180~3600	0.111~44.43	0.124	0.1778	0.676	1.0989	43.309

CONSTANT TORQUE				CONSTANT HORSEPOWER			
HZ	HP	RPM	TORQUE (lb-ft)	HZ	HP	RPM	TORQUE (lb-ft)
6~60	3~30	360~3600	44.43	60~90	30	3600~5400	44.43~29.62

TYPICAL PERFORMANCE

FULL LOAD RPM	EFFICIENCY				POWER FACTOR			SOUND PRESSURE LEVEL @ 3 FT Db(A)
	FULL LOAD		3/4 LOAD %	1/2 LOAD %	FULL LOAD %	3/4 LOAD %	1/2 LOAD %	
	MIN.%	NOM.%						
3545	91.7	93	93.6	93	91	90.5	87.5	77

CURRENTS			NEMA KVA CODE LETTER	SAFE STALL TIME IN SECONDS	
NO LOAD	FULL LOAD	LOCKED ROTOR		COLD	HOT
AT 460 VOLT	AT 460 VOLT	AT 460 VOLT			
6.04	33.20	218	G	24	17

TORQUE				INERTIA			ACCEL TIME (DOL)		ALLOWABLE STARTS PER HOUR	
FULL LOAD (lb-ft)	LOCKED ROTOR %FLT	PULL UP %FLT	BREAK DOWN %FLT	ROTOR WR ² (lb-ft ²)	NEMA LOAD WK ² (lb-ft ²)	MAX ALLOWABLE WK ² (lb-ft ²)	NEMA LOAD WK ² Sec	MAX ALLOWABLE WK ² Sec	COLD	HOT
44.43	175	140	240	2.831	30	73	4.36	10.07	2	1

APPROVED:	M. PRATER	DRAWING NO.	31057HH0302	REVISION:	1
-----------	------------------	-------------	--------------------	-----------	----------

DATE:
May 9, 2005

CONNECTION DIAGRAM

CATALOG NO.:
HH0302



SCHEMATIC - Δ CONNECTION

ACROSS THE LINE CONNECTION



460 VOLT CONNECTION