

DATE  
Sept. 12, 2005  
CAT. #: HH1002

OUTLINE DIMENSIONS  
3-PHASE INDUCTION MOTOR

MOTOR TYPE:  
AEHH  
FRAME NO. 405TS

Pole	HP	kW	Hz	VOLT	Syn. Speed r/min(rpm)
2	100	75	60	460	3600

Ins	Rating	Dimension in	Approx Weight	Bearings
F	CONT.	inches	1144 lbs.	DE: 6313C3 NDE: 6313ZC35C

Totally Enclosed Fan Cooled Type, Squirrel-cage Rotor.

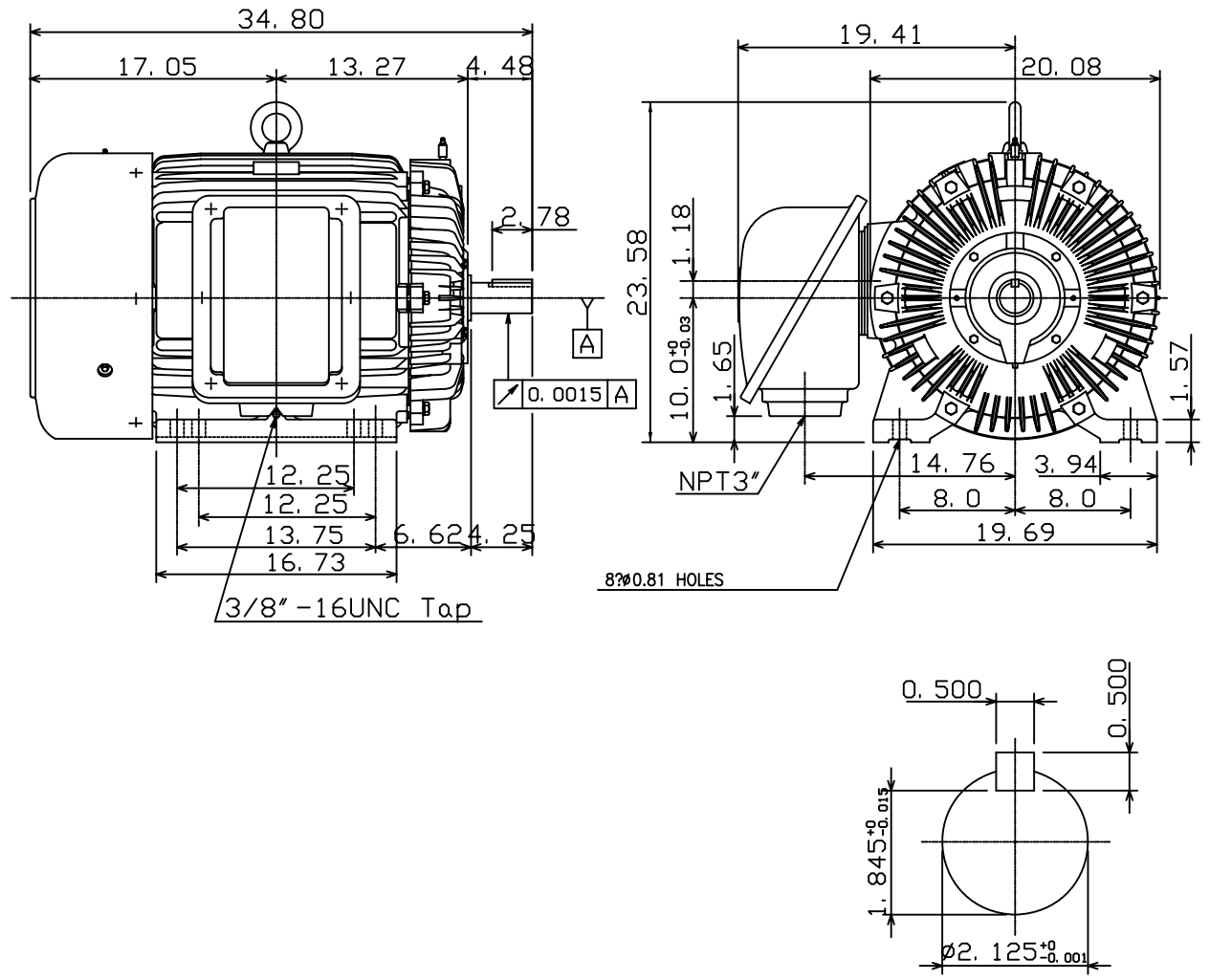

◇		
---	--	--

DWN.	K. L. KUD	01-18-05
CHKD.	C. H. KAD	02-02-05
APPD.	M. C. TSAI	02-02-05



DWG NO.  
31049M634570

# TECO Westinghouse

ISSUED <b>8/29/2014</b>	<b>PERFORMANCE DATA</b> <b>3-PHASE INDUCTION MOTOR</b>	ENCLOSURE <b>TEFC</b>
TYPE <b>AEHH</b>		CATALOG# <b>HH1002</b>

### NAMEPLATE INFORMATION

OUTPUT		POLE	FRAME SIZE	VOLTAGE	HZ	RATED AMBIENT	INS. CLASS	NEMA DESIGN	TIME RATING	SERVICE FACTOR
HP	KW									
<b>100</b>	<b>74.6</b>	<b>2</b>	<b>405TS</b>	<b>460</b>	<b>60</b>	<b>40°C</b>	<b>F</b>	<b>B</b>	<b>CONT.</b>	<b>1.15</b>

### VARIABLE FREQUENCY DRIVE SERVICE

VARIABLE TORQUE				OHMS/PHASE EQUIVALENT WYE CIRCUIT (AT RATED OPERATING TEMPERATURE 25°C)				
HZ	HP	RPM	TORQUE (lb-ft)	R1	R2	X1	X2	X <sub>m</sub>
<b>3~60</b>	<b>0.0125~100</b>	<b>180~3600</b>	<b>0.365~147.5</b>	<b>0.0183</b>	<b>0.045</b>	<b>0.2342</b>	<b>0.2919</b>	<b>13.316</b>

CONSTANT TORQUE				CONSTANT HORSEPOWER			
HZ	HP	RPM	TORQUE (lb-ft)	HZ	HP	RPM	TORQUE (lb-ft)
<b>6~60</b>	<b>10~100</b>	<b>360~3600</b>	<b>147.5</b>	<b>60</b>	<b>100</b>	<b>3600</b>	<b>147.5</b>

### TYPICAL PERFORMANCE

FULL LOAD RPM	EFFICIENCY				POWER FACTOR			SOUND PRESSURE LEVEL @ 3 FT Db(A)
	FULL LOAD		3/4 LOAD %	1/2 LOAD %	FULL LOAD %	3/4 LOAD %	1/2 LOAD %	
	MIN.%	NOM.%						
<b>3560</b>	<b>94.5</b>	<b>95.4</b>	<b>95.8</b>	<b>95.4</b>	<b>92</b>	<b>91.5</b>	<b>88.5</b>	<b>85</b>

CURRENTS			NEMA KVA CODE LETTER	SAFE STALL TIME IN SECONDS	
NO LOAD	FULL LOAD	LOCKED ROTOR		COLD	HOT
AT 460 VOLT	AT 460 VOLT	AT 460 VOLT			
<b>19.6</b>	<b>107.00</b>	<b>725</b>	<b>G</b>	<b>17</b>	<b>12</b>

TORQUE				INERTIA			ACCEL TIME (DOL)		ALLOWABLE STARTS PER HOUR	
FULL LOAD (lb-ft)	LOCKED ROTOR %FLT	PULL UP %FLT	BREAK DOWN %FLT	ROTOR WR <sup>2</sup> (lb-ft <sup>2</sup> )	NEMA LOAD WK <sup>2</sup> (lb-ft <sup>2</sup> )	MAX ALLOWABLE WK <sup>2</sup> (lb-ft <sup>2</sup> )	NEMA LOAD WK <sup>2</sup> Sec	MAX ALLOWABLE WK <sup>2</sup> Sec	COLD	HOT
<b>147.50</b>	<b>140</b>	<b>125</b>	<b>270</b>	<b>10.773</b>	<b>92</b>	<b>213</b>	<b>4.06</b>	<b>8.84</b>	<b>2</b>	<b>1</b>

APPROVED:	<b>M. PRATER</b>	DRAWING NO.	<b>31057HH1002</b>	REVISION:	<b>1</b>
-----------	------------------	-------------	--------------------	-----------	----------

DATE:  
May 9, 2005

# CONNECTION DIAGRAM

CATALOG NO.:  
**HH1002**

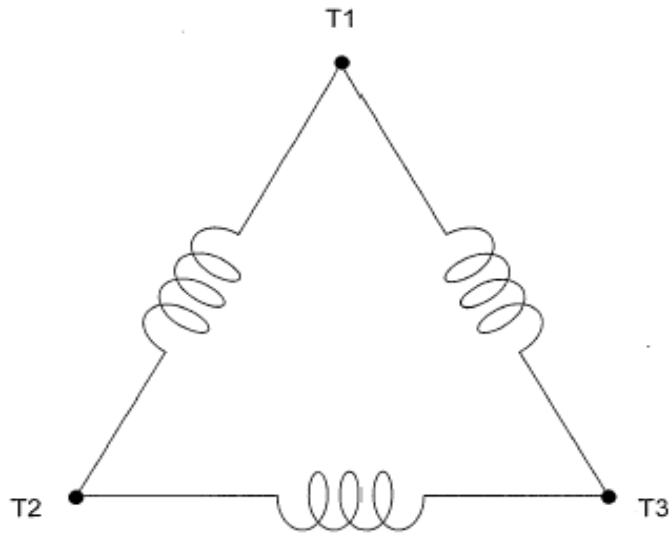

**SCHEMATIC - Δ CONNECTION**

## ACROSS THE LINE CONNECTION

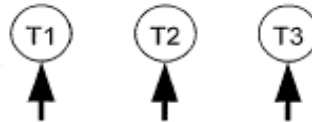

**460 VOLT CONNECTION**