

TYPE	OUTPUT		POLE	RATING	VOLTAGE	Hz	SYNSPEED
	HP.	KW.					
AEHH	150	111.9	2	CONT.	460	60	3600

TOTALLY ENCLOSED FAN-COOLED TYPE, SQUIRREL-CAGE ROTOR

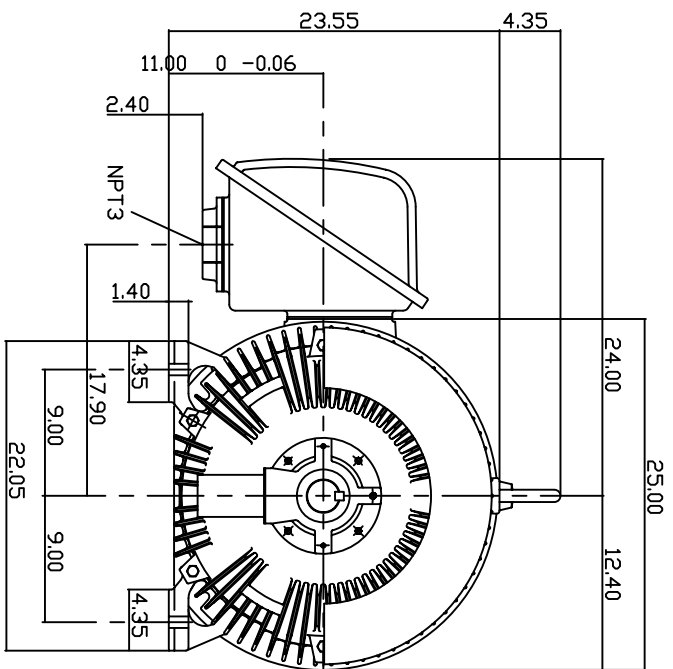
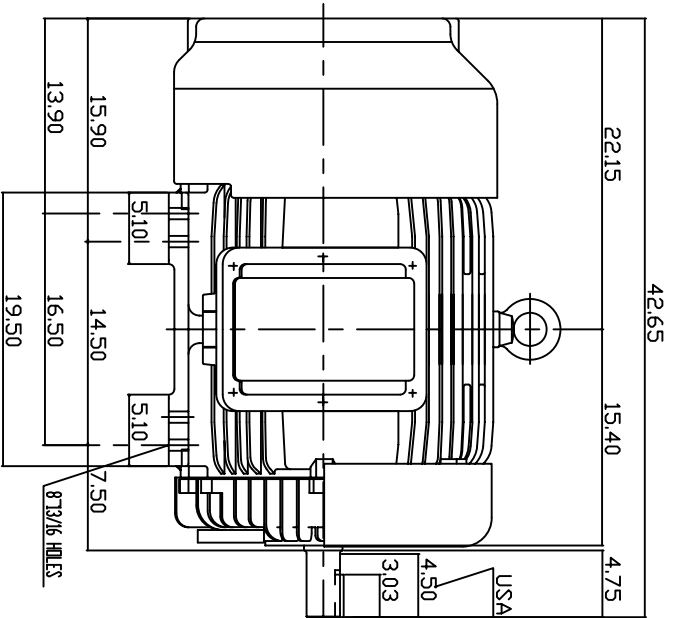

NOTE:

1. DIMENSIONS IN INCH
2. FRAME NO. 445TS
3. F CLASS INSULATION, S.F.115
4. FOR DIRECT FLEXIBLE COUPLING
5. ENCLOSURE: IP55
6. BEARING SIZE: DRIVE END: 6314C3  
NON-DRIVE END: 6314C3
7. APPROX. WEIGHT: 1700 LBS
8. NON-SPARKING FAN.
9. NOISE: BELOW 83 DBA AT 1 METER, NO LOAD.

TW-56C

DWN.	T.H.Pan	DATE
CHKD.	H.HUANG	FEB 18 2005
APPD.	C.WANG	FEB 18 2005

DATE: 06-20-05  
 CATALOG #HH1502  
 OUTLINE DIMENSIONS  
 3-PHASE INDUCTION MOTOR

Westinghouse  
 D/WG NO. 3A040Y699  
 REV. 00

# TECO Westinghouse

ISSUED <b>8/29/2014</b>	<b>PERFORMANCE DATA</b> <b>3-PHASE INDUCTION MOTOR</b>	ENCLOSURE <b>TEFC</b>
TYPE <b>AEHH</b>		CATALOG# <b>HH1502</b>

### NAMEPLATE INFORMATION

OUTPUT		POLE	FRAME SIZE	VOLTAGE	HZ	RATED AMBIENT	INS. CLASS	NEMA DESIGN	TIME RATING	SERVICE FACTOR
HP	KW									
<b>150</b>	<b>112</b>	<b>2</b>	<b>445TS</b>	<b>460</b>	<b>60</b>	<b>40°C</b>	<b>F</b>	<b>B</b>	<b>CONT.</b>	<b>1.15</b>

### VARIABLE FREQUENCY DRIVE SERVICE

VARIABLE TORQUE				OHMS/PHASE EQUIVALENT WYE CIRCUIT (AT RATED OPERATING TEMPERATURE 25°C)				
HZ	HP	RPM	TORQUE (lb-ft)	R1	R2	X1	X2	X <sub>m</sub>
<b>3~60</b>	<b>0.0188~150</b>	<b>180~3600</b>	<b>0.548~220</b>	<b>0.0362</b>	<b>0.029</b>	<b>0.306</b>	<b>0.567</b>	<b>15.5</b>

CONSTANT TORQUE				CONSTANT HORSEPOWER			
HZ	HP	RPM	TORQUE (lb-ft)	HZ	HP	RPM	TORQUE (lb-ft)
<b>6~60</b>	<b>15~150</b>	<b>360~3600</b>	<b>220</b>	<b>60</b>	<b>150</b>	<b>3600</b>	<b>220</b>

### TYPICAL PERFORMANCE

FULL LOAD RPM	EFFICIENCY				POWER FACTOR			SOUND PRESSURE LEVEL @ 3 FT Db(A)
	FULL LOAD		3/4 LOAD %	1/2 LOAD %	FULL LOAD %	3/4 LOAD %	1/2 LOAD %	
	MIN.%	NOM.%						
<b>3566</b>	<b>94.1</b>	<b>95</b>	<b>94.5</b>	<b>93.6</b>	<b>87</b>	<b>84.5</b>	<b>81</b>	<b>83</b>

CURRENTS				NEMA KVA CODE LETTER	SAFE STALL TIME IN SECONDS	
NO LOAD		FULL LOAD			LOCKED ROTOR	
AT 460 VOLT		AT 460 VOLT			AT 460 VOLT	
<b>42</b>		<b>170.00</b>		<b>G</b>	<b>28</b>	<b>19</b>

TORQUE				INERTIA			ACCEL TIME (DOL)		ALLOWABLE STARTS PER HOUR	
FULL LOAD (lb-ft)	LOCKED ROTOR %FLT	PULL UP %FLT	BREAK DOWN %FLT	ROTOR WR <sup>2</sup> (lb-ft <sup>2</sup> )	NEMA LOAD WK <sup>2</sup> (lb-ft <sup>2</sup> )	MAX ALLOWABLE WK <sup>2</sup> (lb-ft <sup>2</sup> )	NEMA LOAD WK <sup>2</sup> Sec	MAX ALLOWABLE WK <sup>2</sup> Sec	COLD	HOT
<b>220.00</b>	<b>110</b>	<b>88</b>	<b>220</b>	<b>20</b>	<b>133</b>	<b>133</b>	<b>4.93</b>	<b>4.93</b>	<b>2</b>	<b>1</b>

APPROVED:	<b>M. PRATER</b>	DRAWING NO.	<b>31057HH1502</b>	REVISION:	<b>1</b>
-----------	------------------	-------------	--------------------	-----------	----------

DATE:  
May 9, 2005

# CONNECTION DIAGRAM

CATALOG NO.:  
**HH1502**



**SCHEMATIC - Δ CONNECTION**

## ACROSS THE LINE CONNECTION



**460 VOLT CONNECTION**