

DATE
APRIL 27, 2003
CATALOG NO.
HH7/56

OUTLINE DIMENSIONS
3-PHASE INDUCTION MOTOR

MOTOR TYPE:
AEHH
FRAME NO. 254T

Pole	HP	KW	Hz	VOLT	Syn.Speed RPM
6	7.5	5.6	60	460	1200

Ins	Rating	Dimension in	Approx Weight	Bearings
F	CONT.	inches	297 lbs.	DE: 6309ZC35C NDE: 6307ZC35C

Totally Enclosed Fan-Cooled Type. Squirrel-cage Rotor.

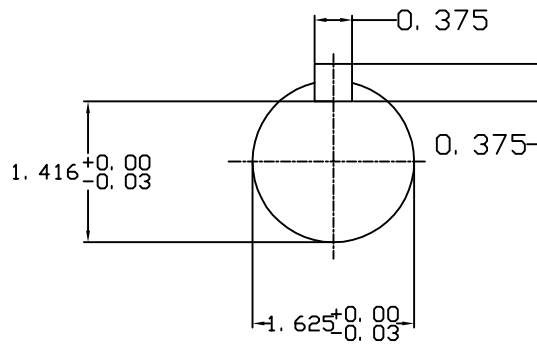
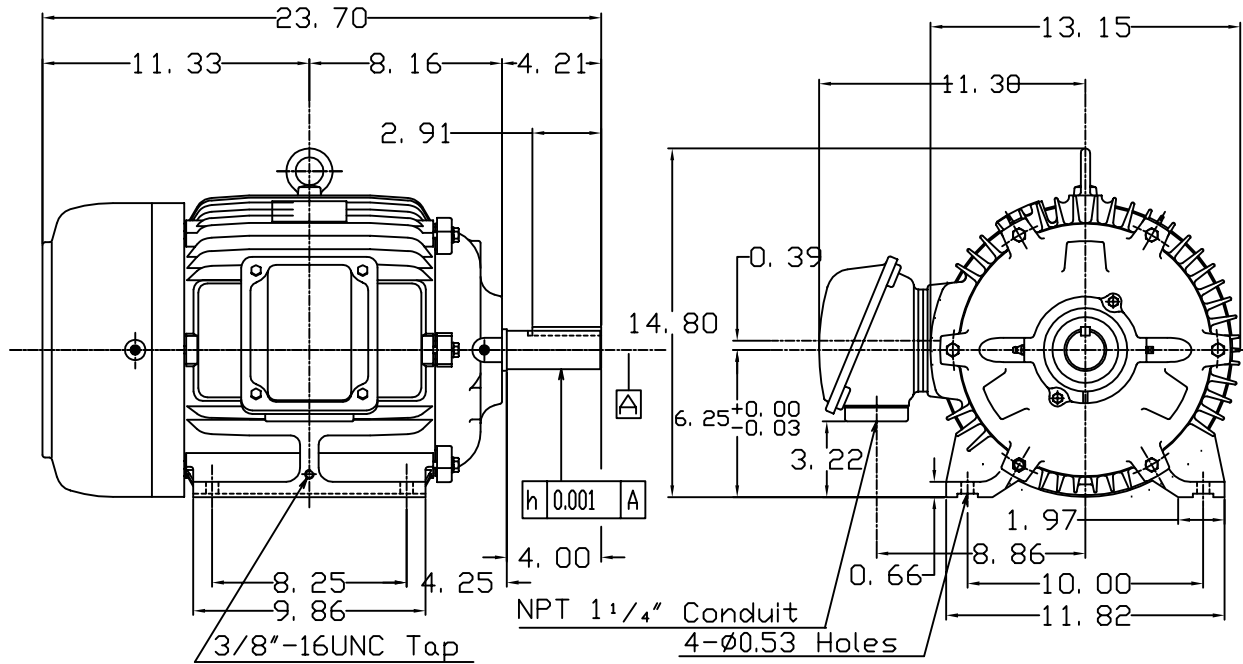

DWN.	簡學民	12-04-98
CHKD.	高金星	12-10-98
APPD.	黃友伯	12-10-98

TECO Westinghouse

DWG NO.
31049M625062

TECO Westinghouse

ISSUED 8/29/2014	PERFORMANCE DATA 3-PHASE INDUCTION MOTOR	ENCLOSURE TEFC
TYPE AEHH		CATALOG# HH7/56

NAMEPLATE INFORMATION

OUTPUT		POLE	FRAME SIZE	VOLTAGE	HZ	RATED AMBIENT	INS. CLASS	NEMA DESIGN	TIME RATING	SERVICE FACTOR
HP	KW									
7.5	5.6	6	254T	460	60	40°C	F	B	CONT.	1.15

VARIABLE FREQUENCY DRIVE SERVICE

VARIABLE TORQUE				OHMS/PHASE EQUIVALENT WYE CIRCUIT (AT RATED OPERATING TEMPERATURE 25°C)				
HZ	HP	RPM	TORQUE (lb-ft)	R1	R2	X1	X2	X _m
3~60	0.001~7.5	60~1200	0.087~33.66	0.6647	0.9084	2.4019	3.8208	57.875

CONSTANT TORQUE				CONSTANT HORSEPOWER			
HZ	HP	RPM	TORQUE (lb-ft)	HZ	HP	RPM	TORQUE (lb-ft)
6~60	.75~7.5	120~1200	33.66	60~120	7.5	1200~2400	33.66~16.83

TYPICAL PERFORMANCE

FULL LOAD RPM	EFFICIENCY				POWER FACTOR			SOUND PRESSURE LEVEL @ 3 FT Db(A)
	FULL LOAD		3/4 LOAD %	1/2 LOAD %	FULL LOAD %	3/4 LOAD %	1/2 LOAD %	
	MIN.%	NOM.%						
1170	89.5	91	91	89.5	80.5	75	64	59

CURRENTS			NEMA KVA CODE LETTER	SAFE STALL TIME IN SECONDS	
NO LOAD	FULL LOAD	LOCKED ROTOR		COLD	HOT
AT 460 VOLT	AT 460 VOLT	AT 460 VOLT			
4.41	9.59	64	H	36	25

TORQUE				INERTIA			ACCEL TIME (DOL)		ALLOWABLE STARTS PER HOUR	
FULL LOAD (lb-ft)	LOCKED ROTOR %FLT	PULL UP %FLT	BREAK DOWN %FLT	ROTOR WR ² (lb-ft ²)	NEMA LOAD WK ² (lb-ft ²)	MAX ALLOWABLE WK ² (lb-ft ²)	NEMA LOAD WK ² Sec	MAX ALLOWABLE WK ² Sec	COLD	HOT
33.66	240	215	270	2.158	104	375	5.17	18.37	2	1

APPROVED:	M. PRATER	DRAWING NO.	31057HH7/56	REVISION:	1
-----------	------------------	-------------	--------------------	-----------	----------