

BALDOR® • RELIANCE 

Product Information Packet

JMEWDM4103T

25HP, 1770RPM, 3PH, 60HZ, 284JM, TEFC, F1

Part Detail							
Revision:	B	Status:	PRD/A	Change #:		Proprietary:	No
Type:	AC	Elec. Spec:	10WGZ624	CD Diagram:	CD0005	Mfg Plant:	
Mech. Spec:		Layout:	10LY-000-754	Poles:	04	Created Date:	01-16-2020
Base:		Eff. Date:	12-08-2020	Leads:	9#10		

Specs			
Catalog Number:	JMEWDM4103T	Feedback Device:	NO FEEDBACK
Enclosure:	TEFC	Heater Indicator:	No Heater
Frame:	284JM	Insulation Class:	F
Frame Material:	Iron	Inverter Code:	Inverter Duty
Output @ Frequency:	25.000 HP @ 60 HZ	IP Rating:	NONE
Synchronous Speed @ Frequency:	1800 RPM @ 60 HZ	KVA Code:	F
Voltage @ Frequency:	460.0 V @ 60 HZ	Lifting Lugs:	Standard Lifting Lugs
	230.0 V @ 60 HZ	Locked Bearing Indicator:	Locked Bearing
XP Class and Group:	None	Motor Lead Termination:	Flying Leads
XP Division:	Not Applicable	Motor Type:	1056M
Agency Approvals:	CSA	Mounting Arrangement:	F1
	CSA EEV	Power Factor:	85
	UR	Product Family:	Washdown Features
Auxillary Box:	No Auxillary Box	Pulley Face Code:	C-Face
Auxillary Box Lead Termination:	None	Rodent Screen:	None
Base Indicator:	Rigid	Shaft Ground Indicator:	No Shaft Grounding
Bearing Grease Type:	Polyrex EM (-20F +300F)	Shaft Rotation:	Reversible
Blower:	None	Speed Code:	Single Speed

Current @ Voltage:	30.000 A @ 460.0 V	Motor Standards:	NEMA
	60.000 A @ 230.0 V	Starting Method:	Direct on line
Design Code:	B	Thermal Device - Bearing:	None
Drip Cover:	No Drip Cover	Thermal Device - Winding:	None
Duty Rating:	CONT	Vibration Sensor Indicator:	No Vibration Sensor
Electrically Isolated Bearing:	Not Electrically Isolated	Winding Thermal 1:	None
		Winding Thermal 2:	None

Nameplate NP1669	
CAT.NO.	JMEWDM4103T
SPEC.	10-0000-1310
HP	25
VOLTS	230/460
AMP	60/30
RPM	1770
FRAME	284JM
SER.F.	1.15
NEMA-NOM-EFF	93.6
RATING	40C AMB-CONT
CC	010A
DE	6312
ENCL	TEFC
BLANK	20:1 CT&VT, 1.00SF
	HZ 60
	CODE F
	PF 85
	ODE 6309
	DES B
	PH 3
	CLASS F
	USABLE AT 208V

Parts List		
Part Number	Description	Quantity
SA378609	SA 10-0000-1310	1.000 EA
RA368567	RA 10-0000-1310	1.000 EA
LB1115N	LABEL,LIFTING DEVICE (ON ROLLS)	1.000 EA
LC0005E01	SPL CONN.DIA./WARN.LABEL(LC0005/LB1119)	1.000 EA
NP1669	SS WD SUPER-E UL CSA CC REV MTG	1.000 EA
85XU0407S04	4X1/4 U DRIVE PIN STAINLESS	2.000 EA
MN416A01	TAG-INSTAL-MAINT no wire (2100/bx) 4/22	1.000 EA
10FH1007WP	FAN COVER, W/WHITE EPOXY, PRIMED CASTING	1.000 EA
HW1001S31	WASHER, 5/16 SPLT LK, STAINLESS STEEL	3.000 EA
10XN3118S24	5/16-18 X 1 1/2 HEX HD SS	3.000 EA
09FN3001C02	EXTERNAL FAN, PLASTIC (COMES W/SCREW FRO	1.000 EA
HW2500A25	WOODRUFF KEY USA #1008 #BLOW CARBON STEE	1.000 EA
MJ1000A02	GREASE, MOBIL POLYREX EM - 124047	0.130 LB
WD4100A02	DP-1000 HEYCO PLUG OR 62MP1000 MICRO PL	1.000 EA
10EP1104A42WP	FREP, MACH W/O GRSRS & RET HLS W/WHITE E	1.000 EA
10XN3816S32	3/8-16 X 2 HEX HD CAP SCREW, STAINLE	4.000 EA
HW1001S38	WASHER, 3/8 SPLT LK, STAINLESS STEEL	4.000 EA
HW4600B67	V-RING SLINGER 1.770 X 2.170 X .28 VITON	1.000 EA
HW5100A11	W3917-042 WVY WSHR (WB)	1.000 EA
HA4054	SHORT T-DRAIN FITTING, .125" N.P.T.	1.000 EA
10EP1304A04P	PU ENDPLATE, MACH W/EPOXY, PRIMED CASTIN	1.000 EA
10XN3816S28	3/8-16 X 1 3/4 HEX HD CAP SCREW, STAINLE	4.000 EA
HW4600B41	V-RING SLINGER 2.125 X 2.880 X 0.280	1.000 EA
HW4600B14	22358 SEAL (CHIC. RAW)	1.000 EA

Parts List (continued)		
Part Number	Description	Quantity
10XN3118S44	5/16-18 X 2 3/4 HEX HEAD SS	4.000 EA
HA4054	SHORT T-DRAIN FITTING, .125" N.P.T.	1.000 EA
10CB1000A352P	CONDUIT BOX, MACH W/EPOXY PRIMER	1.000 EA
09GS1010	GASKET, DWG, LEADWIRE SEPERATOR	1.000 EA
10XN3118K16	5/16-18 X 1' GRADE #5, STL, ZINC PLATE	4.000 EA
HW1001A31	LOCKWASHER 5/16, ZINC PLT.591 OD, .319 I	4.000 EA
WD1000B25	GND LUG, BURNDY L125HP OR T&B L125HP-BB	1.000 EA
19XW3118G08	.31-18X.50,HEX WSHR HD,TAPTITE 2,GREEN	1.000 EA
10CB1503A01P	CONDUIT BOX LIPPED LID, MACH W/EPXY PRMR	1.000 EA
14GS1003	GASKET CONDUIT BOX LID, NEOP	1.000 EA
10XN2520S16	41/4-20 X 1 HEX HEAD SS	4.000 EA
HW1001S25	WASHER, 1/4 SPLT LK, STAINLESS STEEL	4.000 EA
MG1025W01	WILKOFASST, 781.01, SIGNAL WHITE #9003	0.125 GA
MJ5001A27	32220KN GRAY SEALER *MIN BUY 4 QTS=1GAL	0.031 QT
MJ5002A01	SILICON RUBBER SEALANT, 732CL 10.3 OZ TU	0.033 EA
MJ5002A01	SILICON RUBBER SEALANT, 732CL 10.3 OZ TU	1.000 EA
10PA1000	PACKAGING GROUP COMBINED PRINT PK1023A06	1.000 EA
HW2502E21	SS KEY 1/4 X 2.375	1.000 EA

AC Induction Motor Performance Data

Record # 62434

Typical performance - not guaranteed values

Winding: 10WGZ624-R002		Type: 1056M		Enclosure: TEFC	
Nameplate Data			460 V, 60 Hz: High Voltage Connection		
Rated Output (HP)	25	Full Load Torque	74.31 LB-FT		
Volts	460	Start Configuration	direct on line		
Full Load Amps	30	Breakdown Torque	197 LB-FT		
R.P.M.	1770	Pull-up Torque	91.4 LB-FT		
Hz	60	Phase	3	Locked-rotor Torque	115 LB-FT
NEMA Design Code	B	KVA Code	F	Starting Current	173 A
Service Factor (S.F.)	1	No-load Current	10.4 A		
NEMA Nom. Eff.	93.6	Power Factor	85	Line-line Res. @ 25°C	0.29877 Ω
Rating - Duty	40C AMB-CONT		Temp. Rise @ Rated Load	54°C	
			Locked-rotor Power Factor	30.3	

Load Characteristics 460 V, 60 Hz, 25 HP

% of Rated Load	25	50	75	100	125	150
Power Factor	51	73	81	85	86	86
Efficiency	91	93.8	94.1	93.7	92.9	91.8
Speed	1792.8	1785.5	1778.9	1770.7	1762.4	1751.5
Line amperes	12.5	17	22.9	29.5	36.5	44.7

Performance Graph at 460V, 60Hz, 25.0HP Typical performance - Not guaranteed values

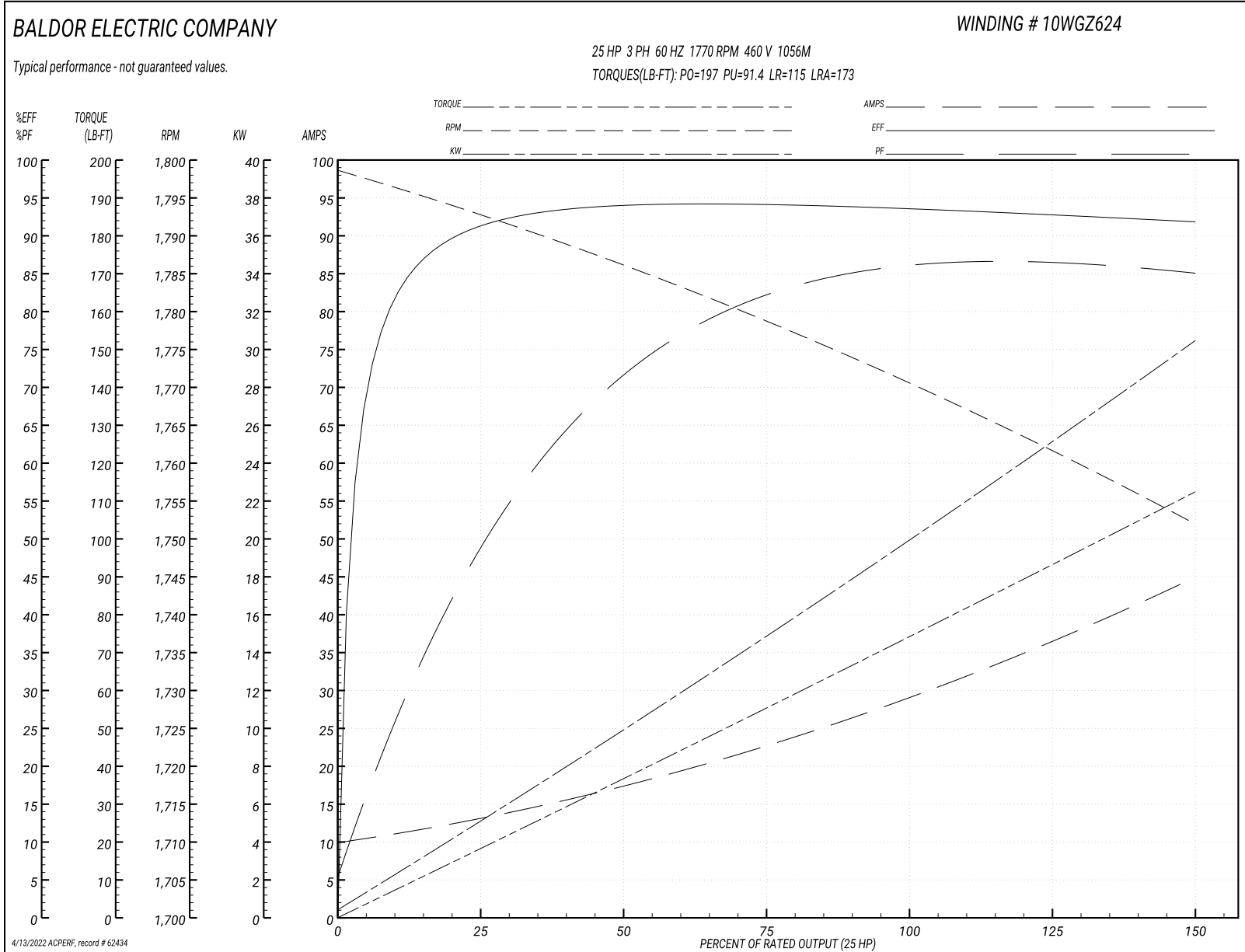

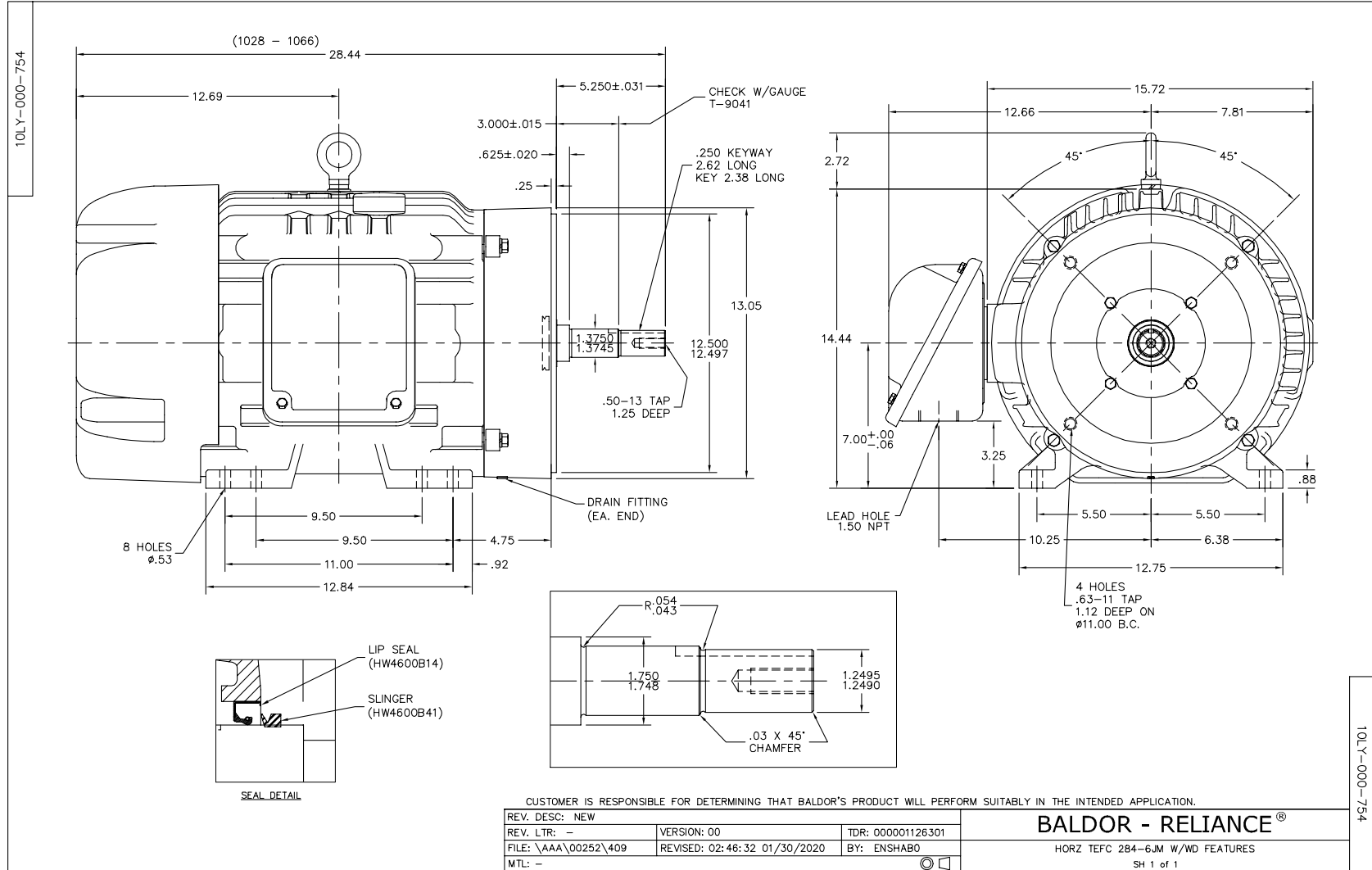

CD0005



LOW VOLTAGE
(2Y)



LINE

HIGH VOLTAGE
(1Y)

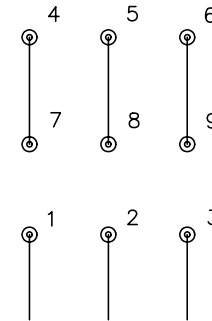

LINE

NOTES:

1. INTERCHANGE ANY TWO LINE LEADS TO REVERSE ROTATION.
2. OPTIONAL THERMOSTATS ARE PROVIDED WHEN SPECIFIED.
3. ACTUAL NUMBER OF INTERNAL PARALLEL CIRCUITS MAY BE A MULTIPLE OF THOSE SHOWN ABOVE.
4. LEAD COLORS ARE OPTIONAL. LEADS MUST ALWAYS BE NUMBERED AS SHOWN.

REV. DESC: REVISE TO SHOW OPTIONAL COLORS			
REV. LTR: E	BY: JLP	REVISED: 01/19/99 10:15	TDR: 0171435
900000		FILE: AAA00005140	MDL: -
		MTL: -	

BALDOR ELECTRIC Co.

3PH, DV, 9 LEADS

CD0005

Marketing maintained PDF of MN416:

<http://www.baldor.com/support/Literature/Load.ashx/MN416?ManNumber=MN416>