

DATE
Nov. 7, 2008
Cat. #: JPP0052

OUTLINE DIMENSIONS
3-PHASE INDUCTION MOTOR

MOTOR TYPE:
AEEAJP-NE
FRAME NO. 184JP

Pole	HP	kW	Hz	VOLT	Syn. Speed r/min(rpm)
2	5	3.73	60	230/460	3600

Ins	Rating	Dimension in	Approx Weight	Bearings
F	CONT.	inches	100 lbs	DE: 6307ZZ NDE: 6306ZZ

Totally Enclosed Fan Cooled Type. Squirrel Cage Rotor.

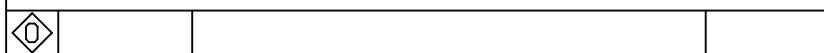
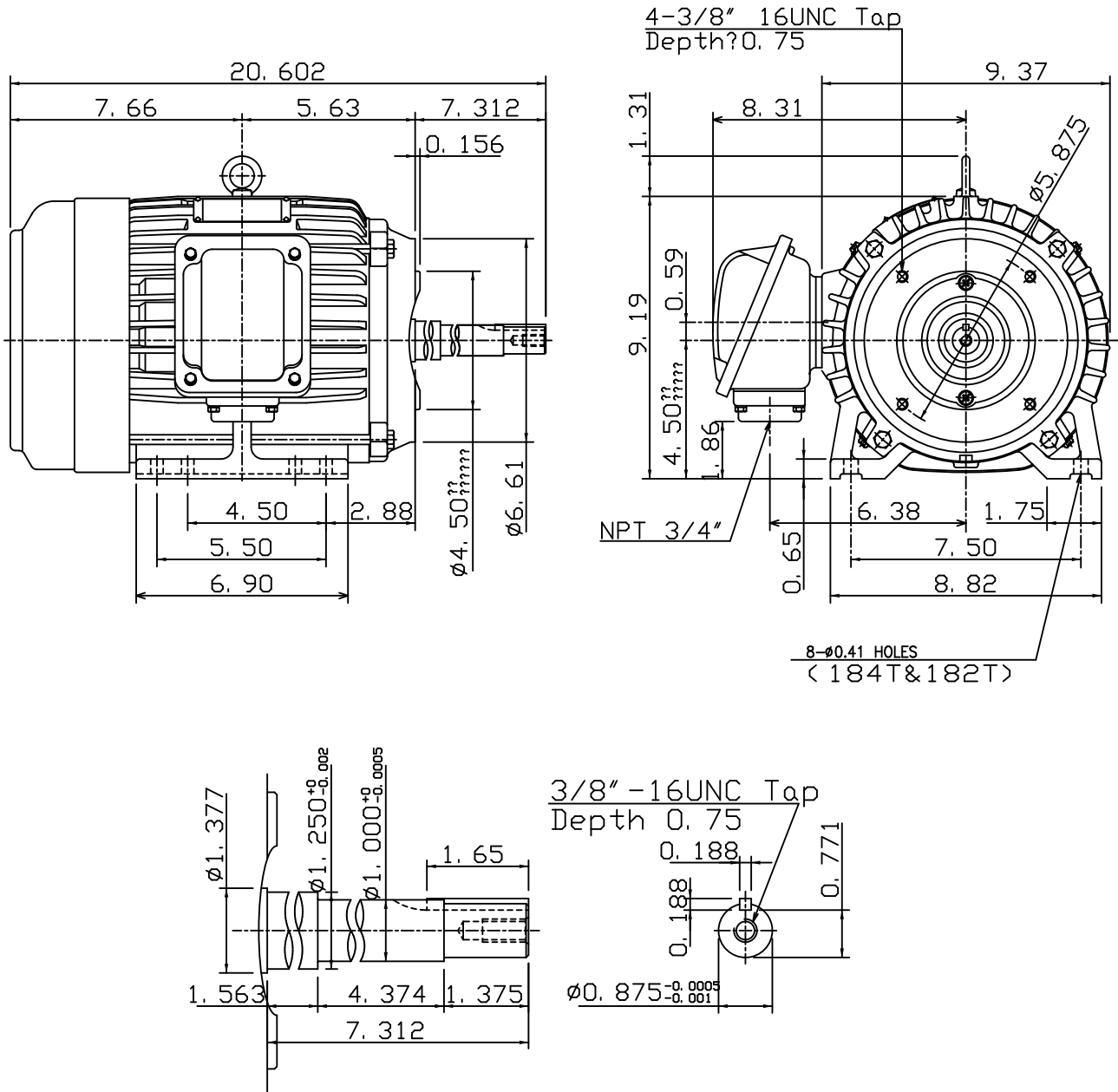

DWN. J. H. LIANG 01-10-08
CHKD. H. C. YAN 02-12-08
APPD. M. C. TSAI 02-12-08



DWG NO.
31049H740060

TECO Westinghouse

ISSUED 2/3/2017	PERFORMANCE DATA 3-PHASE INDUCTION MOTOR	ENCLOSURE TEFC
TYPE AEHH8NJP		CATALOG# JPP0052

NAMEPLATE INFORMATION

OUTPUT		POLE	FRAME SIZE	VOLTAGE	HZ	RATED AMBIENT	INS. CLASS	NEMA DESIGN	TIME RATING	SERVICE FACTOR
HP	KW									
5	3.7	2	184T	230/460	60	40°C	F	B	CONT.	1.15

VARIABLE FREQUENCY DRIVE SERVICE

VARIABLE TORQUE				OHMS/PHASE EQUIVALENT WYE CIRCUIT (AT RATED OPERATING TEMPERATURE 25°C)				
HZ	HP	RPM	TORQUE (lb-ft)	R1	R2	X1	X2	X _m
3~60	0.0006~5	180~3600	0.0175~7.544	1.2805	1.5435	3.4342	5.0121	186.67

CONSTANT TORQUE				CONSTANT HORSEPOWER			
HZ	HP	RPM	TORQUE (lb-ft)	HZ	HP	RPM	TORQUE (lb-ft)
6~60	.5~5	360~3600	7.544	60~120	5	3600~7200	7.544~3.772

TYPICAL PERFORMANCE

FULL LOAD RPM	EFFICIENCY				POWER FACTOR			SOUND PRESSURE LEVEL @ 3 FT Db(A)
	FULL LOAD		3/4 LOAD %	1/2 LOAD %	FULL LOAD %	3/4 LOAD %	1/2 LOAD %	
	MIN.%	NOM.%						
3480	86.5	88.5	89.5	89.5	92.5	91	85.5	65

CURRENTS									NEMA KVA CODE LETTER	SAFE STALL TIME IN SECONDS	
NO LOAD			FULL LOAD			LOCKED ROTOR				COLD	HOT
AT 208 VOLT	AT 230 VOLT	AT 460 VOLT	AT 208 VOLT	AT 230 VOLT	AT 460 VOLT	AT 208 VOLT	AT 230 VOLT	AT 460 VOLT			
2.61	2.80	1.4	12.61	11.40	5.72	83.2	92.0	46	J	17	12

TORQUE				INERTIA			ACCEL TIME (DOL)		ALLOWABLE STARTS PER HOUR	
FULL LOAD (lb-ft)	LOCKED ROTOR %FLT	PULL UP %FLT	BREAK DOWN %FLT	ROTOR WR ² (lb-ft ²)	NEMA LOAD WK ² (lb-ft ²)	MAX ALLOWABLE WK ² (lb-ft ²)	NEMA LOAD WK ² Sec	MAX ALLOWABLE WK ² Sec	COLD	HOT
7.54	290	230	320	0.272	5.7	17	3.27	9.46	2	1

APPROVED:	M. PRATER	DRAWING NO.	31057JPP0052	REVISION:	1
-----------	------------------	-------------	---------------------	-----------	----------

DATE:
June 28, 2005

CONNECTION DIAGRAM

CATALOG NO.:
JPP

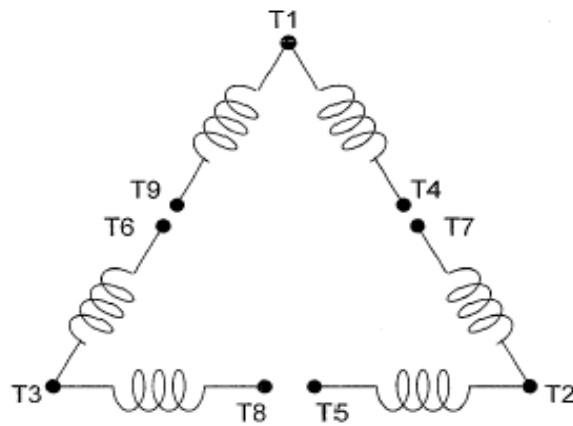

SCHEMATIC - 2Δ / Δ CONNECTION

ACROSS THE LINE CONNECTION

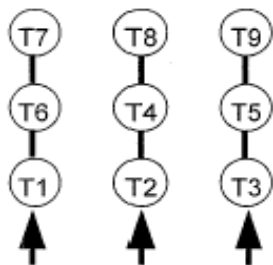

**LINE
230 VOLT CONNECTION**

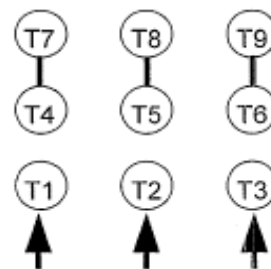

**LINE
460 VOLT CONNECTION**