

Totally Enclosed Fan-Cooled Type, Squirrel-Cage Rotor.

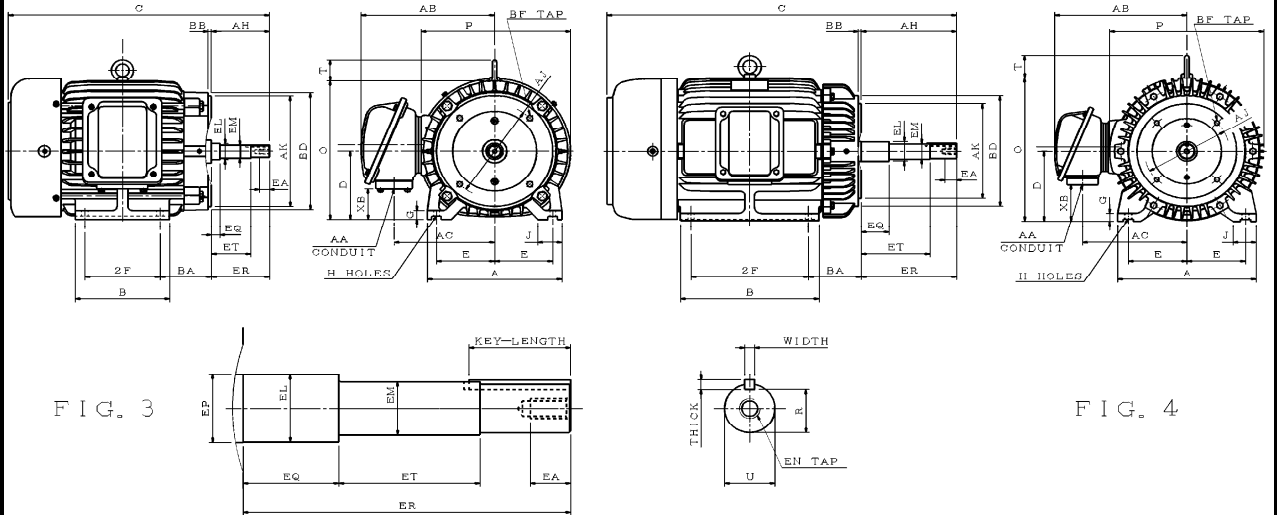

Dimension in inches

Output (HP)			FRAME SIZE	FIG. NO.	A	B	C	D	E	2F	G	H	J	O	P	T	AH	AJ	AK	BA	BB	BD	BF
2P	4P	6P			9.85	6.90	23.255	5.25	4.25	5.50	0.70	0.41	1.75	10.63	11.10	1.65	8.125	7.25	8.5	3.75	0.25	8.98	4-1/2"13UNC
7.5	7.5	3	213JP	3	9.85	6.90	23.255	5.25	4.25	5.50	0.70	0.41	1.75	10.63	11.10	1.65	8.125	7.25	8.5	3.75	0.25	8.98	4-1/2"13UNC
10	10	5	215JP	3	9.85	8.35	24.745	5.25	4.25	7.00	0.70	0.41	1.75	10.63	11.10	1.65	8.125	7.25	8.5	3.75	0.25	8.98	4-1/2"13UNC
15	15	7.5	254JP	4	11.82	9.85	28.155	6.25	5.00	8.25	0.66	0.53	1.97	13.15	13.15	1.65	8.125	7.25	8.5	4.50	0.25	9.92	4-1/2"13UNC
20	20	10	256JP	4	11.82	11.81	29.905	6.25	5.00	10.00	0.66	0.53	1.97	13.15	13.15	1.65	8.125	7.25	8.5	4.50	0.25	9.92	4-1/2"13UNC

FRAME SIZE	KEY			KEYSEAT R	TERMINAL HOUSING				SHAFT EXTENSION								BEARINGS		APPROX. WEIGHT LBS	
	WIDTH	THICK	LENGTH		AA	AB	AC	XB	EA	EL	EM	EN	EP	EQ	ER	ET	U	DRIVE END		OPPOSITE DRIVE END
213JP	0.25	0.25	2.53	1.112	1"	9.78	7.34	2.34	1	1.75	1.375	1/2"-13UNC	1.763	2.375	8.125	5.875	1.25	6309ZZ	6306ZZ	186
215JP	0.25	0.25	2.53	1.112	1"	9.78	7.34	2.34	1	1.75	1.375	1/2"-13UNC	1.763	2.375	8.125	5.875	1.25	6309ZZ	6306ZZ	213
254JP	0.25	0.25	2.52	1.112	1 1/4"	11.3	8.86	3.22	1	1.75	1.375	1/2"-13UNC	1.763	2.375	8.125	5.875	1.25	6309ZZ	6307ZZ	325
256JP	0.25	0.25	2.52	1.112	1 1/4"	11.3	8.86	3.22	1	1.75	1.375	1/2"-13UNC	1.763	2.375	8.125	5.875	1.25	6309ZZ	6307ZZ	354

Note :

1. Dimension AK tolerance : +0.000 inches, -0.003 inches.
2. Dimension EL tolerance : +0.000 inches, -0.002 inches.
3. Dimension EM tolerance : +0.000 inches, -0.0005 inches.
4. Dimension U tolerance : -0.0005 inches, -0.001 inches.
5. Dimension D tolerance : +0.00 inches, -0.03 inches.
6. Dimension AH tolerance : +0.031 inches, -0.031 inches.
7. Dimension BB tolerance : +0.062 inches, -0.000 inches.
8. Dimension EQ tolerance : +0.015 inches, -0.015 inches.
9. Dimension ET tolerance : +0.015 inches, -0.015 inches.

ISSUED 20-May-10	<b>PERFORMANCE DATA</b> 3-PHASE SQUIRREL CAGE HIGH EFFICIENCY INDUCTION MOTORS	MODEL <b>AEHH8N-JP</b>
REVISED		PAGE 3 of 14



TEFC, NEMA T-FRAME, DESIGN - B or C,  
CLASS F, 40°C AMBIENT, CONTINUOUS DUTY,  
S.F. 1.15 460V 60Hz

**TYPICAL PERFORMANCE (460V)**

HP	FULL LOAD RPM	FRAME SIZE	EFFICIENCY(%)				POWER FACTOR(%)			CURRENT		TORQUE				ROTOR Wk <sup>2</sup> lb-ft <sup>2</sup>	NEMA CODE LETTER
			FULL LOAD		3/4 LOAD	1/2 LOAD	FULL LOAD	3/4 LOAD	1/2 LOAD	FULL LOAD (A)	LOCKED ROTOR (A)	FULL LOAD lb-ft	LOCKED ROTOR %FLT	PULL UP %FLT	BREAK DOWN %FLT		
			NOM.	MIN.	NOM.	NOM.	NOM.	NOM.	NOM.	NOM.	NOM.	NOM.	NOM.	NOM.	NOM.		
1	3465	143JP	82.5	80.0	81.5	78.5	85.0	79.5	68.5	1.34	15	1.515	350	365	400	0.046	N
	1745	143JP	85.5	82.5	84.0	81.5	73.0	64.5	51.5	1.50	15	3.009	310	280	410	0.086	N
	1150	145JP	82.5	80.0	82.5	80.0	65.5	57.0	44.5	1.73	15	4.566	250	220	300	0.122	N
1.5	3465	143JP	84.0	81.5	84.0	81.5	83.5	77.0	65.0	2.00	20	2.273	340	280	350	0.052	M
	1730	145JP	86.5	84.0	86.5	85.5	78.0	70.0	57.0	2.08	20	4.552	300	260	360	0.093	M
	1170	182JP	87.5	85.5	85.5	82.5	63.5	55.0	42.5	2.53	20	6.731	210	190	350	0.313	M
2	3465	145JP	86.5	84.0	86.5	85.5	86.0	80.5	70.0	2.52	25	3.031	350	315	390	0.064	L
	1740	145JP	86.5	84.0	84.0	84.0	78.0	70.0	57.0	2.78	25	6.035	270	220	330	0.108	L
	1170	184JP	88.5	86.5	88.5	86.5	70.5	63.0	50.5	3.00	25	8.975	180	150	270	0.423	L
3	3490	182JP	88.5	86.5	90.2	89.5	90.0	87.0	79.5	3.53	32	4.513	280	250	380	0.190	K
	1755	182JP	89.5	87.5	89.5	87.5	84.0	79.5	68.5	3.74	32	8.975	225	175	345	0.404	K
	1175	213JP	89.5	87.5	89.5	87.5	78.0	70.5	58.5	4.02	32	13.41	210	180	340	0.918	K
5	3480	184JP	88.5	86.5	89.5	89.5	92.5	91.0	85.5	5.72	46	7.544	290	230	320	0.272	J
	1745	184JP	89.5	87.5	88.5	88.5	85.5	81.5	71.5	6.12	46	15.04	185	140	285	0.422	J
	1170	215JP	91.0	89.5	91.0	89.5	82.5	77.0	65.5	6.24	46	22.44	190	160	300	1.224	J
7.5	3510	213JP	91.0	89.5	91.0	90.2	89.0	87.0	80.0	8.67	64	11.22	200	175	275	0.448	H
	1755	213JP	91.7	90.2	91.0	89.5	86.5	82.0	72.0	8.85	64	22.44	250	155	270	0.848	H
	1170	254JP	91.0	89.5	91.0	89.5	80.5	75.0	64.0	9.59	64	33.66	240	215	270	2.158	H
10	3510	215JP	91.0	89.5	91.7	91.0	89.5	88.5	82.5	11.5	81	14.96	220	180	260	0.573	H
	1755	215JP	91.7	90.2	91.0	91.0	88.0	84.0	75.5	11.6	81	29.92	250	145	260	1.082	H
	1170	256JP	91.0	89.5	91.7	90.2	80.5	75.0	64.0	12.8	81	44.87	225	185	250	2.872	H
15	3525	254JP	92.4	91.0	92.4	91.7	91.5	90.5	86.0	16.0	116	22.34	210	180	270	1.088	G
	1765	254JP	92.4	91.0	93.0	92.4	88.0	85.0	77.0	17.3	116	44.62	245	180	270	2.179	G
	1175	284JP	92.4	91.0	93.0	93.0	83.5	79.5	70.5	18.2	116	67.03	215	180	230	6.823	G
20	3520	256JP	92.4	91.0	93.0	93.6	92.5	91.5	88.0	21.9	145	29.83	210	180	260	1.407	G
	1760	256JP	93.0	91.7	92.4	92.4	87.5	84.5	78.5	23.0	145	59.66	200	145	240	2.871	G
	1170	286JP	91.7	90.2	92.4	92.4	84.0	81.0	73.0	24.3	145	89.75	210	160	225	8.340	G
25	3545	284JP	92.4	91.0	93.0	92.4	91.0	90.5	86.5	27.8	183	37.03	175	135	250	2.507	G
	1765	284JP	93.6	92.4	93.6	93.6	86.0	83.0	77.0	29.1	183	74.37	205	165	240	4.586	G
	1170	324JP	93.0	91.7	93.6	93.6	83.0	80.0	71.5	30.3	183	112.2	200	155	205	11.877	G
30	3545	286JP	93.0	91.7	93.6	93.0	91.0	90.5	87.5	33.2	218	44.43	175	140	240	2.831	G
	1770	286JP	93.6	92.4	93.6	93.6	87.5	85.5	79.5	34.3	218	88.99	200	160	235	5.274	G
	1175	326JP	93.0	91.7	93.6	93.6	80.5	78.5	71.0	37.5	218	134.1	210	180	230	12.372	G
40	3550	324JP	94.1	93.0	94.5	94.1	90.0	89.0	84.5	44.2	290	59.16	150	130	240	3.590	G
	1770	324JP	94.1	93.0	94.5	94.5	86.0	84.5	78.5	46.3	290	118.7	205	170	220	8.624	G
	1180	364JP	94.1	93.0	94.5	94.1	86.5	84.5	78.0	46.0	290	178.0	200	150	220	17.937	G
50	3550	326JP	94.1	93.0	94.5	94.5	91.0	90.0	86.5	54.7	363	73.95	150	130	240	4.488	G
	1770	326JP	94.5	93.6	95.0	95.0	87.0	86.0	80.5	56.9	363	148.3	210	170	220	10.124	G
	1180	365JP	94.1	93.0	94.5	93.6	86.0	83.0	75.5	57.8	363	222.5	225	170	240	21.386	G
60	3550	364JP	94.1	93.0	94.5	94.1	93.0	92.0	88.5	64.2	435	88.74	145	130	240	7.379	G
	1775	364JP	95.0	94.1	95.0	94.5	86.5	83.0	75.5	68.4	435	177.5	200	155	240	12.229	G
75	3555	365JP	94.5	93.6	95.0	95.0	93.0	92.5	89.0	79.9	543	110.8	145	130	250	9.056	G
	1775	365JP	95.4	94.5	95.4	95.0	86.5	83.5	75.5	85.1	543	221.8	200	165	250	14.674	G

- NOTE :
- The above are typical values based on test according to ANSI / IEEE standard 112 method B.
  - Breakdown & locked rotor torques are shown as average expected values.
  - Efficiency, power factor, speed and torque are the same for other voltages.  
Current values vary inversely with voltage.
  - Tolerance According to NEMA MG1-12 & IEC 60034-1.
  - Data subject to change without notice.

APPD.	M.C.Tsai	20-May-10	<b>TECO Electric &amp; Mac</b>	DWG NO.
CHKD.	C.L.Huang	27-Apr-10		<b>31057D98622</b>
DWN.	AMO	15-Apr-10		

DATE:  
Dec. 7, 2016

# CONNECTION DIAGRAM

CATALOG NO.:  
JPP0154

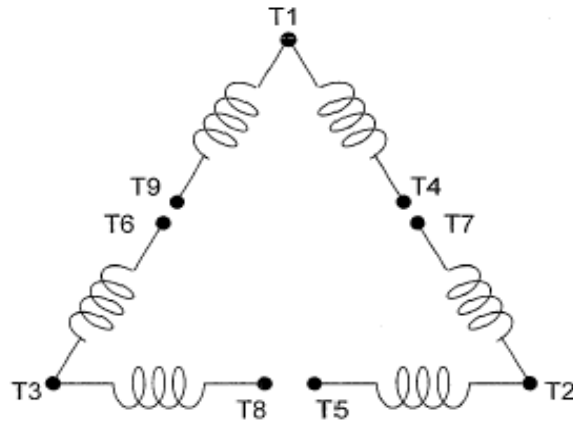

**SCHEMATIC - 2Δ / Δ CONNECTION**

## ACROSS THE LINE CONNECTION

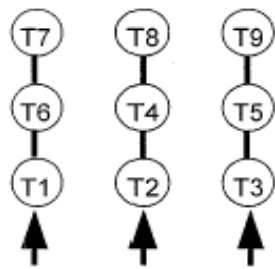

**LINE  
230 VOLT CONNECTION**

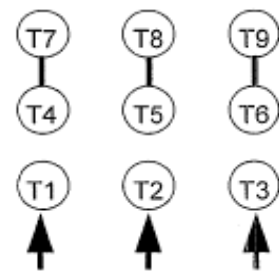

**LINE  
460 VOLT CONNECTION**