

DATE  
JUNE 30, 2009  
Cat. #: JPP7/54

OUTLINE DIMENSIONS  
3-PHASE INDUCTION MOTOR

MOTOR TYPE:  
AEHH8N-JP  
FRAME NO. 213JP

Pole	HP	kW	Hz	VOLT	Syn. Speed r/min(rpm)
4	7.5	5.6	60	230/460	1800

Ins	Rating	Dimension in	Approx Weight	Bearings
F	CONT.	inches	154 lbs	DE: 6309ZZ NDE: 6306ZZ

Totally Enclosed Fan-Cooled Type. Squirrel-Cage Rotor.

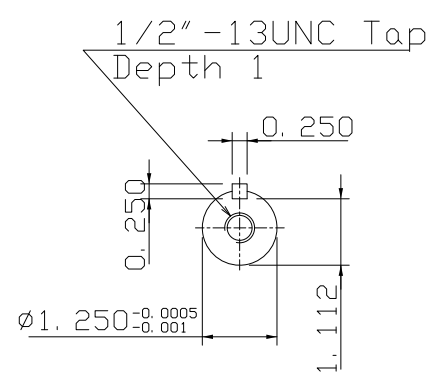
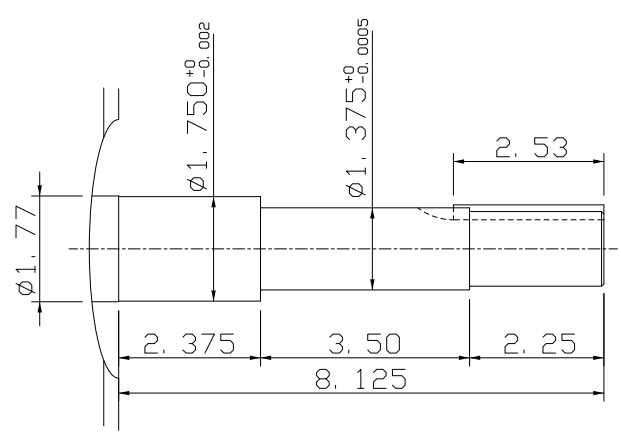
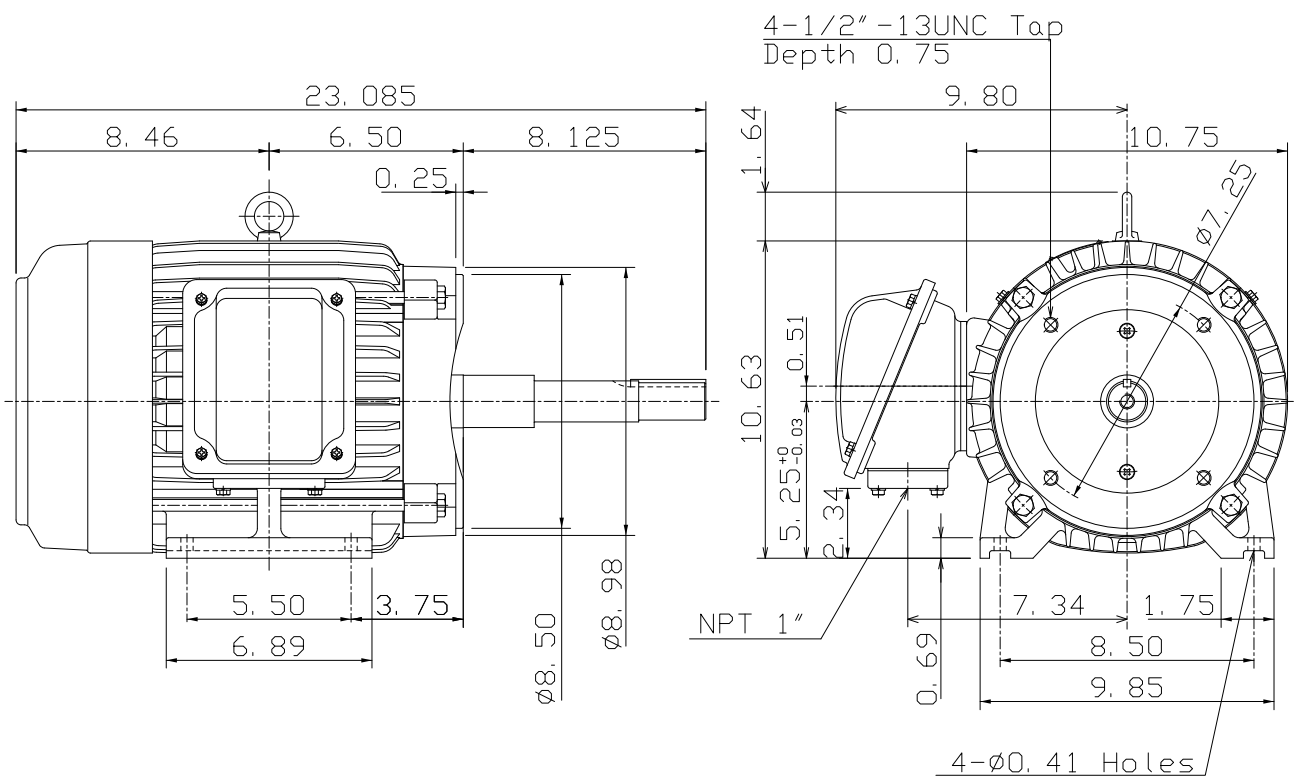

DWN.	J. H. LIANG	01-10-08
CHKD.	H. C. YAN	02-12-08
APPD.	M. C. TSAI	02-12-08



DWG NO.  
31049H741050

# TECO Westinghouse

ISSUED <b>3/21/2019</b>	<b>PERFORMANCE DATA</b> <b>3-PHASE INDUCTION MOTOR</b>	ENCLOSURE <b>TEFC</b>
TYPE <b>AEHH8NJP</b>		CATALOG# <b>JPP7/54</b>

### NAMEPLATE INFORMATION

OUTPUT		POLE	FRAME SIZE	VOLTAGE	HZ	RATED AMBIENT	INS. CLASS	NEMA DESIGN	TIME RATING	SERVICE FACTOR
HP	KW									
<b>7.5</b>	<b>5.6</b>	<b>4</b>	<b>213JP</b>	<b>230/460</b>	<b>60</b>	<b>40°C</b>	<b>F</b>	<b>B</b>	<b>CONT.</b>	<b>1.15</b>

### VARIABLE FREQUENCY DRIVE SERVICE

VARIABLE TORQUE				OHMS/PHASE EQUIVALENT WYE CIRCUIT (AT RATED OPERATING TEMPERATURE 25°C)				
HZ	HP	RPM	TORQUE (lb-ft)	R1	R2	X1	X2	X <sub>m</sub>
<b>3~60</b>	<b>0.001~7.5</b>	<b>90~1800</b>	<b>0.058~22.44</b>	<b>0.7575</b>	<b>0.9336</b>	<b>2.5226</b>	<b>3.3729</b>	<b>97.772</b>

CONSTANT TORQUE				CONSTANT HORSEPOWER			
HZ	HP	RPM	TORQUE (lb-ft)	HZ	HP	RPM	TORQUE (lb-ft)
<b>6~60</b>	<b>.75~7.5</b>	<b>180~1800</b>	<b>22.44</b>	<b>60~120</b>	<b>7.5</b>	<b>1800~3600</b>	<b>22.44~11.22</b>

### TYPICAL PERFORMANCE

FULL LOAD RPM	EFFICIENCY				POWER FACTOR			SOUND PRESSURE LEVEL @ 3 FT Db(A)
	FULL LOAD		3/4 LOAD %	1/2 LOAD %	FULL LOAD %	3/4 LOAD %	1/2 LOAD %	
	MIN.%	NOM.%						
<b>1755</b>	<b>90.2</b>	<b>91.7</b>	<b>91</b>	<b>89.5</b>	<b>86.5</b>	<b>82</b>	<b>72</b>	<b>60</b>

CURRENTS									NEMA KVA CODE LETTER	SAFE STALL TIME IN SECONDS	
NO LOAD			FULL LOAD			LOCKED ROTOR				COLD	HOT
AT	AT	AT	AT	AT	AT	AT	AT	AT			
208 VOLT	230 VOLT	460 VOLT	208 VOLT	230 VOLT	460 VOLT	208 VOLT	230 VOLT	460 VOLT	<b>H</b>	<b>29</b>	<b>20</b>
<b>5.15</b>	<b>5.54</b>	<b>2.77</b>	<b>19.57</b>	<b>17.70</b>	<b>8.85</b>	<b>115.8</b>	<b>128.0</b>	<b>64</b>			

TORQUE				INERTIA			ACCEL TIME (DOL)		ALLOWABLE STARTS PER HOUR	
FULL LOAD (lb-ft)	LOCKED ROTOR %FLT	PULL UP %FLT	BREAK DOWN %FLT	ROTOR WR <sup>2</sup> (lb-ft <sup>2</sup> )	NEMA LOAD WK <sup>2</sup> (lb-ft <sup>2</sup> )	MAX ALLOWABLE WK <sup>2</sup> (lb-ft <sup>2</sup> )	NEMA LOAD WK <sup>2</sup> Sec	MAX ALLOWABLE WK <sup>2</sup> Sec	COLD	HOT
<b>22.44</b>	<b>250</b>	<b>155</b>	<b>270</b>	<b>0.848</b>	<b>39</b>	<b>110</b>	<b>4.31</b>	<b>11.98</b>	<b>2</b>	<b>1</b>

APPROVED:	<b>M. PRATER</b>	DRAWING NO.	<b>31057JPP7/54</b>	REVISION:	<b>1</b>
-----------	------------------	-------------	---------------------	-----------	----------

DATE:  
Dec. 7, 2016

# CONNECTION DIAGRAM

CATALOG NO.:  
JPP7/54



**SCHEMATIC - 2Δ / Δ CONNECTION**

## ACROSS THE LINE CONNECTION

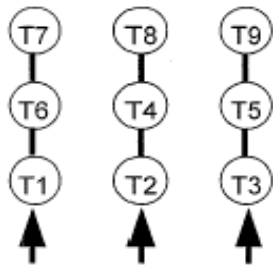

**LINE  
230 VOLT CONNECTION**



**LINE  
460 VOLT CONNECTION**