

PRODUCT INFORMATION PACKET

Model No: 5K37NN30

Catalog No: K160

General Purpose Motor, 0.75 HP, 3 Ph, 60 Hz, 208-230/460 V, 3600 RPM, 56 Frame, TEFC

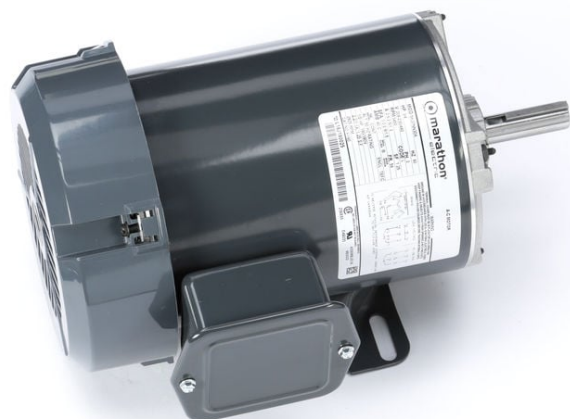

Regal and Marathon are trademarks of Regal Rexnord Corporation or one of its affiliated companies.

©2022 Regal Rexnord Corporation, All Rights Reserved. MC017097E



Nameplate Specifications

Output HP	0.75 Hp	Output KW	0.56 kW
Frequency	60 Hz	Voltage	208-230/460 V
Current	2.6-2.5,1.3 A	Speed	3450 rpm
Service Factor	1.25	Phase	3
Efficiency	74.1 %	Power Factor	0
Duty	Continuous	Insulation Class	B
KVA Code	L	Frame	56
Enclosure	Totally Enclosed Fan Cooled	Thermal Protection	No Protection
Ambient Temperature	40 °C	Drive End Bearing Size	6203
Opp Drive End Bearing Size	6203	UL	Recognized
CSA	Yes	CE	N
Number of Speeds	1		

Technical Specifications

Electrical Type	Three Phase	Starting Method	N/R
Poles	2	Rotation	Counterclockwise/Clockwise
Mounting	Rigid Base	Motor Orientation	ANY
Drive End Bearing	BALL	Opp Drive End Bearing	Ball
Frame Material	Rolled Steel	Overall Length	11.76 in
Frame Length	6.62 in	Shaft Diameter	0.630 in
Shaft Extension	1.88 in		
Outline Drawing	52A102069P5	Connection Drawing	NP149405AA

This is an uncontrolled document once printed or downloaded and is subject to change without notice. Date Created:12/27/2022

SHEET 1
REV 9
52A102069
SIZE DRAWING NO. A

THIRD ANGLE PROJECTION

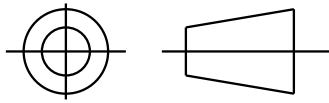

REVISIONS

REV.	DESCRIPTION	DATE	APPROVED
7	REVISED & REDRAWN	11/09/90	B.L.J
8	REVISED BASE SLOT LOCATION	03/07/91	B.L.J
9	CHG MADE AS PER ISO5-3080	12/06/05	GOVARDAN

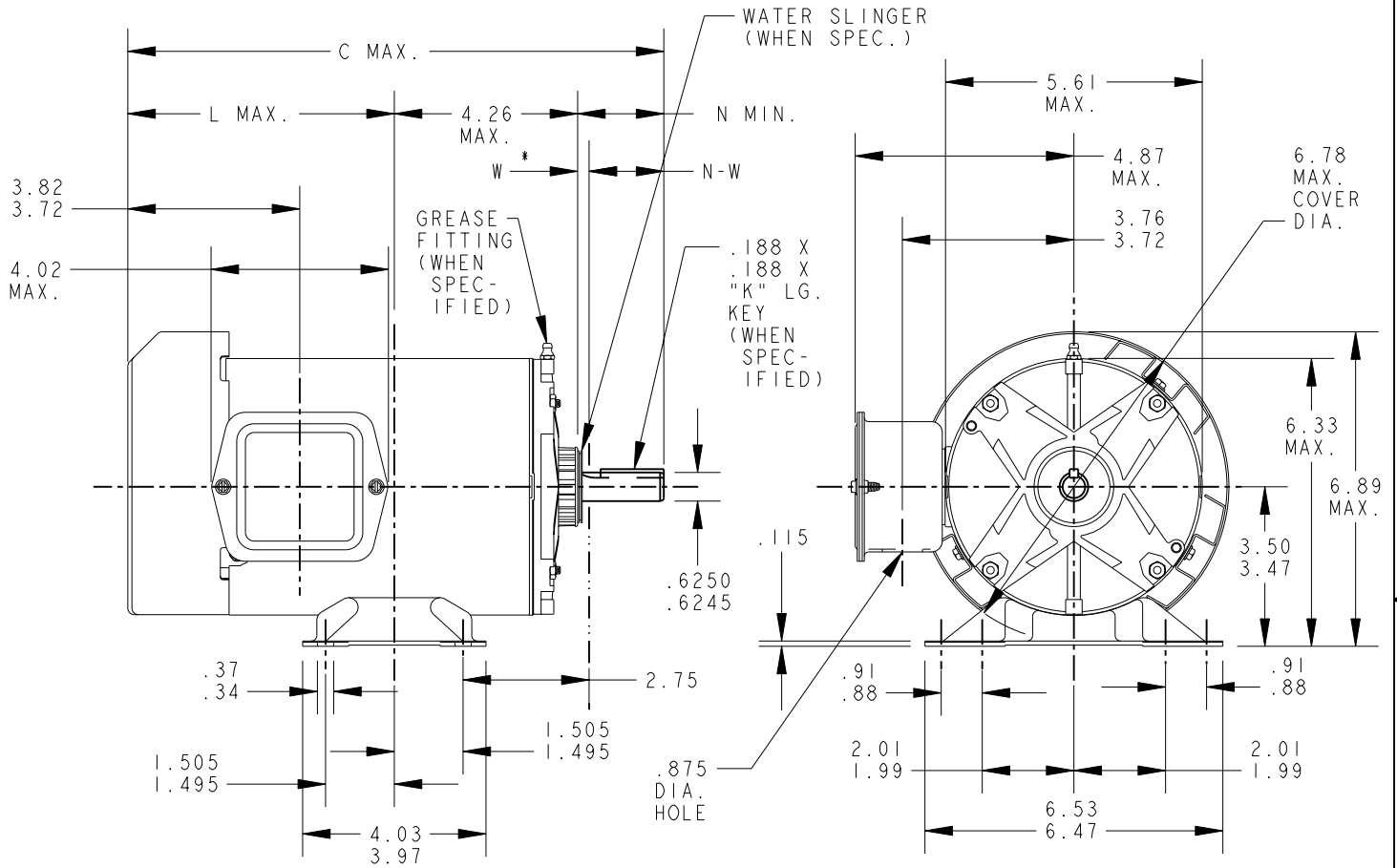

W * IS A CLEARANCE DUE TO VARIATION IN PARTS AND ASSEMBLY

5	K	KH	37	56	11.76	1.38	5.58	1.88	2.01/1.79											
4	K	KH	36	56	11.36	1.38	5.18	1.88	2.01/1.79	9	K	KH	39	56Z	10.05	1.38	3.87	1.88	2.01/1.79	4.91
3	K	KH	35	56	10.93	1.38	4.75	1.88	2.01/1.79	8	K	KH	38	56Z	16.23	1.38	6.18	5.75	5.88/5.66	
2	K	KH	33	56	10.55	1.38	4.37	1.88	2.01/1.79	7	K	KH	39	56	12.89	1.38	6.71	1.88	2.01/1.79	7.75
1	K	KH	32	56	10.30	1.38	4.12	1.88	2.01/1.79	6	K	KH	38	56	12.36	1.38	6.18	1.88	2.01/1.79	
P	TYPE	GE SIZE	NEMA FR.	C	K	L	N	N-W	SHELL LGTH.	P	TYPE	GE SIZE	NEMA FR.	C	K	L	N	N-W	SHELL LGTH.	

SIGNATURES		DATE
MODEL	F.P.K	25/01/77
DETAIL	.	.
CHECKED	.	.
ENGRG	.	.
MFG	.	.
FOR ADDITIONAL INFO REFER TO:	QUALITY	.
APPLIED PRACTICES	ISSUED	B.L.J 03/07/91
DIMENSIONS ARE IN INCHES ✓	SOLID MODEL: 52A102069	



REGAL-BELOIT CORPORATION

TITLE

OUTLINE

GENERAL PURPOSE MOTOR - FORM N - TOTALLY ENCLOSED

OUTBOARD FAN - WELDED BASE - BALL OR SLEEVE BEARING

SIZE DRAWING: A

SCALE: 1.000 REF. No: . SHEET 1 of 1