

PRODUCT INFORMATION PACKET

Model No: 5K38RN30

Catalog No: K163

General Purpose Motor, 1 HP, 3 Ph, 60 Hz, 208-230/460 V, 3600 RPM, 56 Frame, TEFC



Regal and are trademarks of Regal Rexnord Corporation or one of its affiliated companies.
©2022 Regal Rexnord Corporation, All Rights Reserved. MC017097E

Nameplate Specifications

Output HP	1 Hp	Output KW	0.75 kW
Frequency	60 Hz	Voltage	208-230/460 V
Current	3.2-3.0,1.5 A	Speed	3450 rpm
Service Factor	1.25	Phase	3
Efficiency	78.5 %	Power Factor	0
Duty	Continuous	Insulation Class	B
Design Code	B	KVA Code	L
Frame	56	Enclosure	Totally Enclosed Fan Cooled
Thermal Protection	No Protection	Ambient Temperature	40 °C
Drive End Bearing Size	6203	Opp Drive End Bearing Size	6203
UL	Recognized	CSA	Yes
CE	N	Number of Speeds	1

Technical Specifications

Electrical Type	Three Phase	Starting Method	N/R
Poles	2	Rotation	Counterclockwise/Clockwise
Mounting	Rigid Base	Motor Orientation	ANY
Drive End Bearing	BALL	Opp Drive End Bearing	Ball
Frame Material	Rolled Steel	Overall Length	12.36 in
Frame Length	7.22 in	Shaft Diameter	0.630 in
Shaft Extension	1.88 in		
Connection Drawing	113A930FIG2	Outline Drawing	52A102069P6

This is an uncontrolled document once printed or downloaded and is subject to change without notice. Date Created:09/15/2022

SHEET 1
REV 9
52A102069
SIZE DRAWING NO. A

THIRD ANGLE PROJECTION

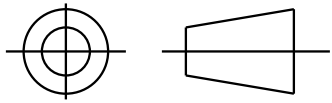

REVISIONS

REV.	DESCRIPTION	DATE	APPROVED
7	REVISED & REDRAWN	11/09/90	B.L.J
8	REVISED BASE SLOT LOCATION	03/07/91	B.L.J
9	CHG MADE AS PER ISO5-3080	12/06/05	GOVARDAN

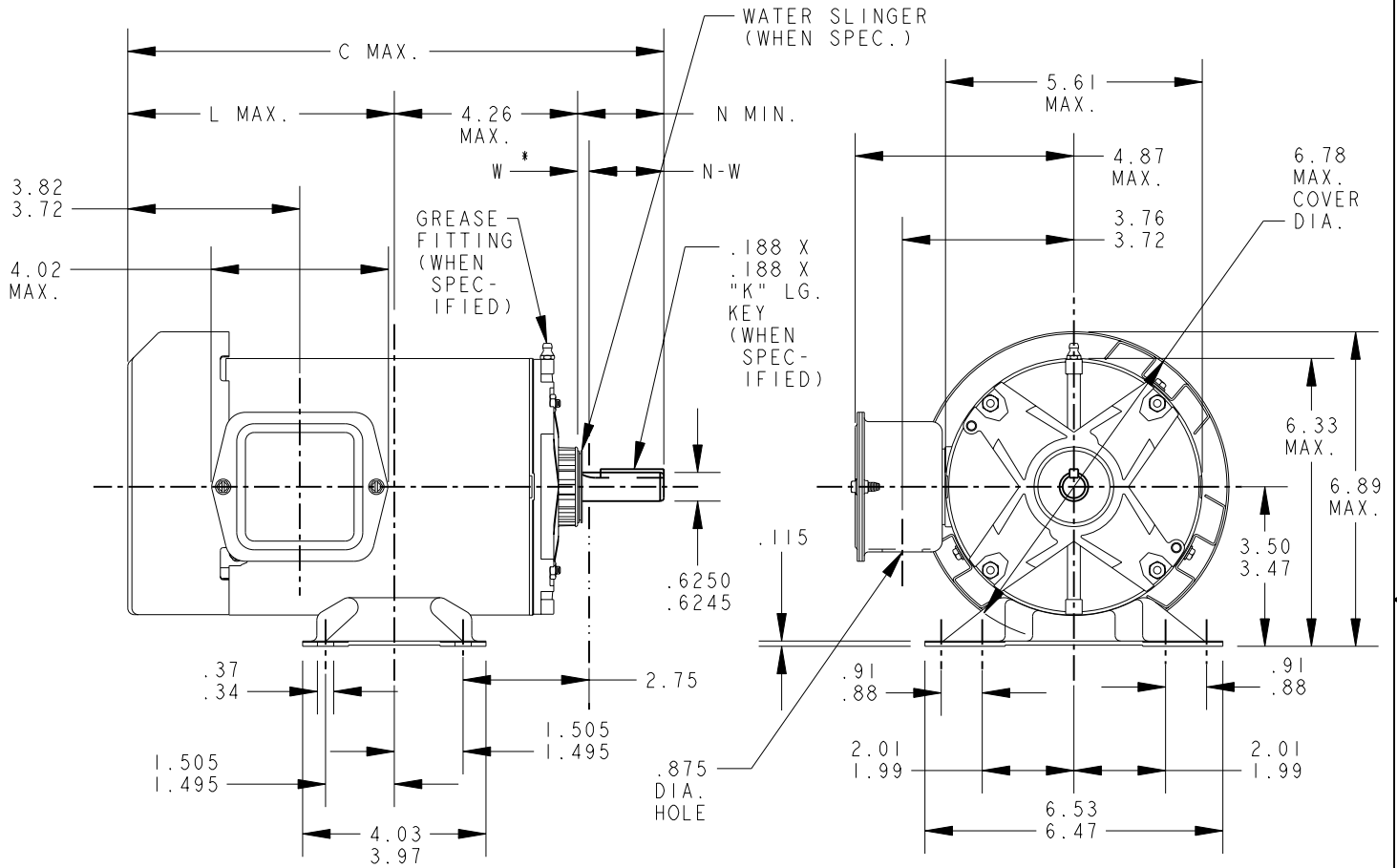

W * IS A CLEARANCE DUE TO VARIATION IN PARTS AND ASSEMBLY

5	K	KH	37	56	11.76	1.38	5.58	1.88	2.01/1.79											
4	K	KH	36	56	11.36	1.38	5.18	1.88	2.01/1.79	9	K	KH	39	56Z	10.05	1.38	3.87	1.88	2.01/1.79	4.91
3	K	KH	35	56	10.93	1.38	4.75	1.88	2.01/1.79	8	K	KH	38	56Z	16.23	1.38	6.18	5.75	5.88/5.66	
2	K	KH	33	56	10.55	1.38	4.37	1.88	2.01/1.79	7	K	KH	39	56	12.89	1.38	6.71	1.88	2.01/1.79	7.75
1	K	KH	32	56	10.30	1.38	4.12	1.88	2.01/1.79	6	K	KH	38	56	12.36	1.38	6.18	1.88	2.01/1.79	
P	TYPE	GE SIZE	NEMA FR.	C	K	L	N	N-W	SHELL LGTH.	P	TYPE	GE SIZE	NEMA FR.	C	K	L	N	N-W	SHELL LGTH.	

SIGNATURES		DATE
MODEL	F.P.K	25/01/77
DETAIL	.	.
CHECKED	.	.
ENGRG	.	.
MFG	.	.
FOR ADDITIONAL INFO REFER TO:	QUALITY	.
APPLIED PRACTICES	ISSUED	B.L.J 03/07/91
DIMENSIONS ARE IN INCHES ✓	SOLID MODEL: 52A102069	



REGAL-BELOIT CORPORATION

TITLE

OUTLINE

GENERAL PURPOSE MOTOR - FORM N - TOTALLY ENCLOSED

OUTBOARD FAN - WELDED BASE - BALL OR SLEEVE BEARING

SIZE DRAWING: A

SCALE: 1.000 REF. No: . SHEET 1 of 1

RBC PROPRIETARY AND CONFIDENTIAL INFORMATION

This document is the property of REGAL BELOIT CORPORATION ("RBC") including its subsidiaries and divisions and contains proprietary information of RBC. This document is loaned on the express condition that neither it nor the information contained therein shall be disclosed to others without the express written consent of RBC, and that the information shall be used by the recipient only as approved expressly by RBC. This document shall be returned to RBC upon its request. This document may be subject to certain restrictions under U.S. export control laws and regulations.

REVISIONS

REV.	DESCRIPTION	DATE	APPROVED
1	CHG TO RBC FORMAT PER ISO5-1777	06/15/06	MADHU
2	RENAMED 113A930_FIG_2 TO 113A930FIG2 PER ISO7-0972	05/08/07	MADHU

THIRD ANGLE PROJECTION

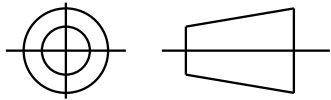

SHEET 2

SIZE DRAWING NO. A

113A930FIG2

FIG. 2

3 PHASE

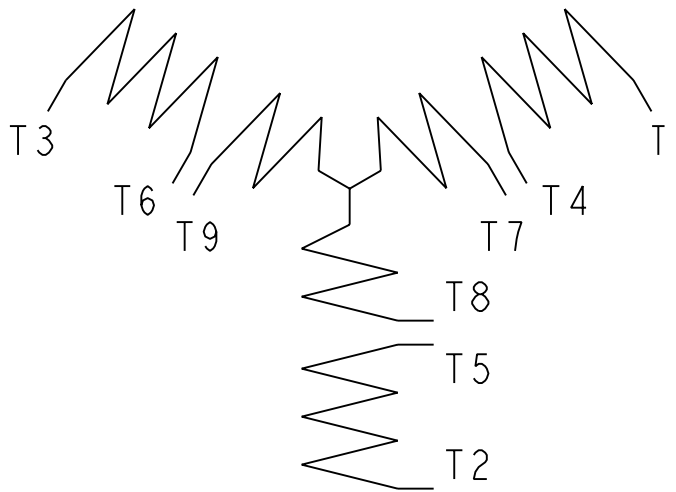

	VOLTS	L1	L2	L3	TOGETHER
2Y	LOW	1-7	2-8	3-9	4-5-6
1Y	HIGH	1	2	3	4-7, 5-8, 6-9

BRAKE MOTORS: CONNECT BRAKE LEADS B1 & B2 TO MOTOR LEADS T7 & T8.

FOR ADDITIONAL INFO REFER TO:	SIGNATURES	DATE
APPLIED PRACTICES	MODEL M. D. PAPE	02/25/03
DIMENSIONS ARE IN INCHES	DETAIL	.
TOLERANCE ON:	CHECKED	.
1 PL DECIMALS ± 0.1	ENGRG	.
2 PL DECIMALS ± 0.02	MFG	.
3 PL DECIMALS ± 0.005	QUALITY	.
ANGLES ± 1.0	ISSUED	M. D. PAPE 02/25/03
FRACTIONS ±		
FINISH ✓		
MATERIAL	SOLID MODEL: 113A930FIG2	



REGAL-BELOIT CORPORATION

TITLE CONNECTION DIAGRAM

SIZE DRAWING A

113A930FIG2

REV 2

SCALE: 1.000

REF. No: .

SHEET 1 of 1

