

# PRODUCT INFORMATION PACKET

Model No: 056T34F5349

Catalog No: K706

General Purpose Motor, 0.75 HP, 3 Ph, 60 Hz, 575 V, 3600 RPM, 56C Frame, TEFC



Regal and Marathon are trademarks of Regal Rexnord Corporation or one of its affiliated companies.

©2022 Regal Rexnord Corporation, All Rights Reserved. MC017097E



### Nameplate Specifications

Output HP	<b>0.75 Hp</b>	Output KW	<b>0.56 kW</b>
Frequency	<b>60 Hz</b>	Voltage	<b>575 V</b>
Current	<b>1.3 A</b>	Speed	<b>3450 rpm</b>
Service Factor	<b>1.15</b>	Phase	<b>3</b>
Efficiency	<b>74 %</b>	Power Factor	<b>69.1</b>
Duty	<b>Continuous</b>	Insulation Class	<b>F</b>
Design Code	<b>B</b>	KVA Code	<b>N</b>
Frame	<b>56C</b>	Enclosure	<b>Totally Enclosed Fan Cooled</b>
Thermal Protection	<b>No Protection</b>	Ambient Temperature	<b>40 °C</b>
Drive End Bearing Size	<b>6203</b>	Opp Drive End Bearing Size	<b>6203</b>
UL	<b>Recognized</b>	CSA	<b>Y</b>
CE	<b>Y</b>	IP Code	<b>43</b>
Number of Speeds	<b>1</b>		

### Technical Specifications

Electrical Type	<b>Squirrel Cage Induction Run</b>	Starting Method	<b>Across The Line</b>
Poles	<b>2</b>	Rotation	<b>Reversible</b>
Resistance Main	<b>5.66 Ohms</b>	Mounting	<b>Bolt-on Base</b>
Motor Orientation	<b>Horizontal Or Up Or Down</b>	Drive End Bearing	<b>Ball</b>
Opp Drive End Bearing	<b>Ball</b>	Frame Material	<b>Rolled Steel</b>
Shaft Type	<b>NEMA 56</b>	Overall Length	<b>11.81 in</b>
Frame Length	<b>6.56 in</b>	Shaft Diameter	<b>0.625 in</b>
Shaft Extension	<b>2.06 in</b>	Assembly/Box Mounting	<b>F1 ONLY</b>
Outline Drawing	<b>A-100141-656</b>	Connection Drawing	<b>A-EE7300</b>

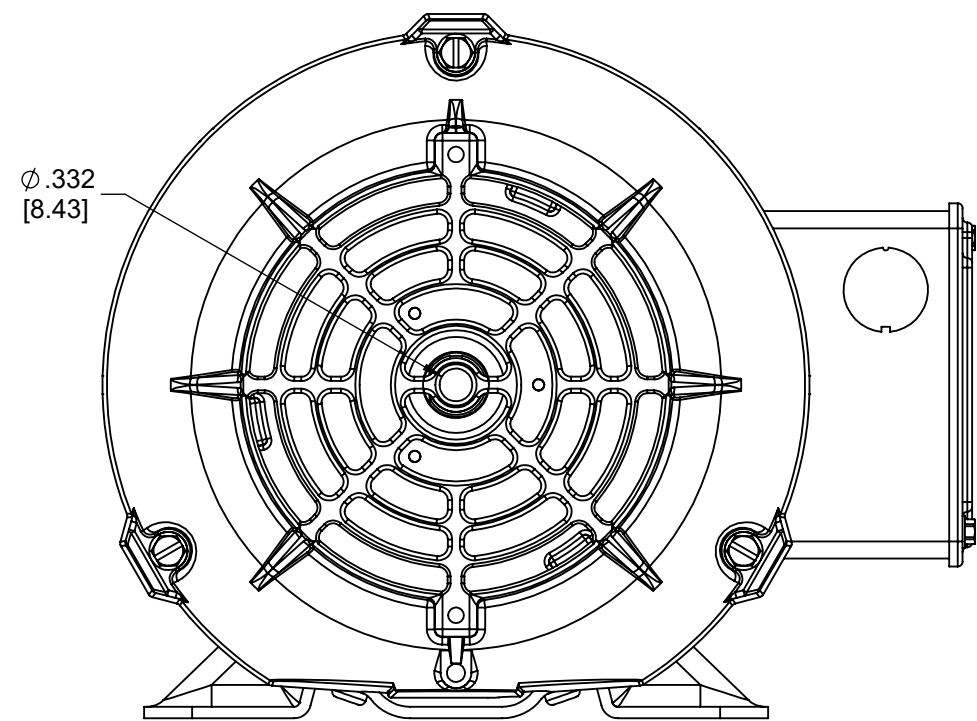

TERM. END

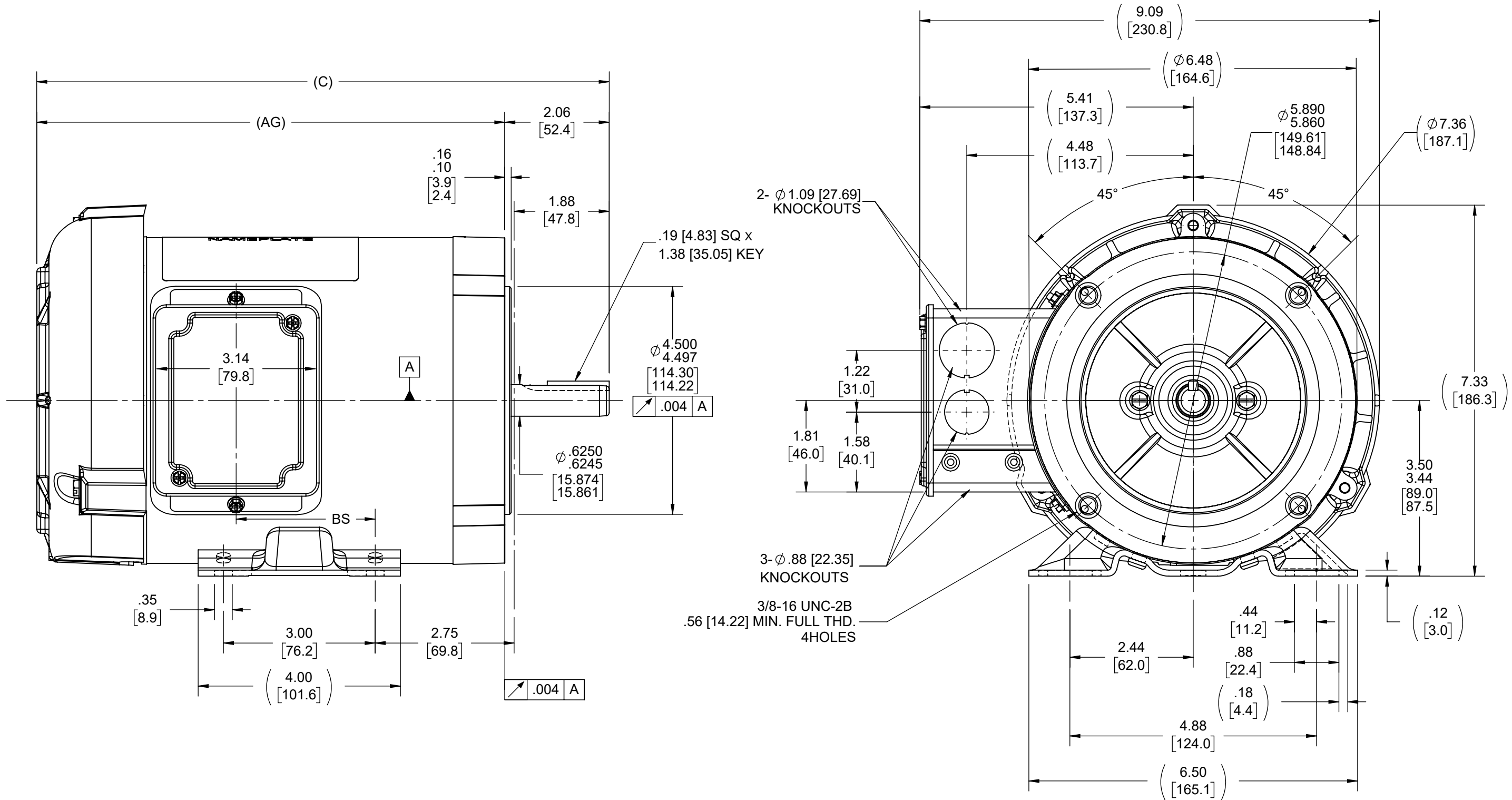

- NOTE :-  
 1. CONDUIT BOX CAN BE ROTATED 180° STEP.  
 2. REMOVABLE BASE.  
 3. NAMEPLATE READ FROM CONDUIT BOX SIDE.

DASH	C	AG	BS
606	11.31[287.27]	9.25 [234.95]	2.75 [69.85]
656	11.81[299.97]	9.75 [247.65]	3.25 [82.55]
706	12.31[312.67]	10.25 [260.35]	3.75 [95.25]
756	12.81[325.37]	10.75 [273.05]	4.25 [107.95]
806	13.31[338.07]	11.25 [285.75]	4.75 [120.65]
856	13.81[350.77]	11.75 [298.45]	5.25 [133.35]

DRAWING REVISION N	REVISION BY A.ARREOLA	REV DATE/@ DATE 12/09/2022	TOLERANCES (EXCEPT AS NOTED): DEC. INCH mm ANGLE .X ±0.1 [±3] ±7° 30" .XX ±0.03 [±0.8] .XXX ±0.005 [±0.13] .XXXX ±0.0005 [±0.013]	DRAWN BY BLR	Regal Beloit America, Inc.
REQUEST NUMBER	APPROVED BY A.ARREOLA	DATE 12/09/2022	REMOVE BURRS & BREAK SHARP EDGES: .003/.015 [.08/.38] X 45° CORNER FILLETS: R.02 [.5] MACHINED SURFACES: 200 INCH/mm 5.1 mm DIMENSIONS IN [BRACKETS] ARE FOR REFERENCE ONLY	DATE 05-27-1997	
REQUEST NUMBER DESCRIPTION				APPROVED BY GK	DESCRIPTION
COPYRIGHT (PER REVISION DATE) REGAL BELOIT AMERICA, INC. ALL RIGHTS RESERVED. PROPRIETARY AND CONFIDENTIAL INFORMATION - THIS DOCUMENT IS THE PROPERTY OF REGAL BELOIT AMERICA, INC. ("OWNER") AND CONTAINS OWNER'S PROPRIETARY INFORMATION. ANY PERSON, CORPORATION OR OTHER FIRM RECEIVING IT IS DEEMED, BY RECEIVING IT, TO AGREE THAT IT, AND/OR ANY PART OF IT, SHALL NOT BE DISCLOSED TO ANY PERSON, CORPORATION OR OTHER ENTITY, DUPLICATED, AND/OR USED, EXCEPT AS EXPRESSLY APPROVED IN WRITING IN ADVANCE BY OWNER. THIS DOCUMENT SHALL BE RETURNED TO OWNER UPON REQUEST. IT MAY BE SUBJECT TO CERTAIN RESTRICTIONS UNDER APPLICABLE EXPORT CONTROL LAWS AND REGULATIONS.				DATE 05-27-1997	OUTLINE
				REFERENCE 100141	56 FR - BB - TEFC - 'C' FACE
				THIRD ANGLE PROJECTION	MATERIAL
				SIZE C	PROCESS/FINISH
				DRAWING NUMBER 100141	
					SHEET 1 OF 1

THREE PHASE - SINGLE VOLTAGE  
MOTOR - CONDUIT BOX @ 'A'

TERMINAL BLOCK WHEN SPECIFIED

TO REVERSE ROTATION:  
INTERCHANGE ANY TWO LINE  
LEAD CONNECTIONS



VIEW OF TERMINAL END

**OPTIONAL CORD CONNECTION**

L1	WHITE
L2	RED
L3	BLACK

DRAWING REVISION AC	REVISION BY BS	REV DATE/© DATE 26/07/2022
REQUEST NUMBER CR-0010402	APPROVED BY SN	DATE 26/07/2022
REQUEST NUMBER DESCRIPTION DRAWING UPDATED		
<small>COPYRIGHT (PER REVISION DATE) REGAL BELOIT AMERICA, INC. ALL RIGHTS RESERVED. PROPRIETARY AND CONFIDENTIAL INFORMATION - THIS DOCUMENT IS THE PROPERTY OF REGAL BELOIT AMERICA, INC. ("OWNER") AND CONTAINS OWNER'S PROPRIETARY INFORMATION. ANY PERSON, CORPORATION OR OTHER FIRM RECEIVING IT IS DEEMED, BY RECEIVING IT, TO AGREE THAT IT, AND/OR ANY PART OF IT, SHALL NOT BE DISCLOSED TO ANY PERSON, CORPORATION OR OTHER ENTITY, DUPLICATED, AND/OR USED, EXCEPT AS EXPRESSLY APPROVED IN WRITING IN ADVANCE BY OWNER. THIS DOCUMENT SHALL BE RETURNED TO OWNER UPON REQUEST. IT MAY BE SUBJECT TO CERTAIN RESTRICTIONS UNDER APPLICABLE EXPORT CONTROL LAWS AND REGULATIONS.</small>		

PRIMARY DIMENSIONS ARE INCH  
mm DIMENSIONS IN [BRACKETS]  
ARE FOR REFERENCE ONLY

DRAWN BY DA
DATE 03-26-1993
APPROVED BY TB
DATE 03-26-1993
REFERENCE
THIRD ANGLE PROJECTION

		Regal Beloit America, Inc.	
DESCRIPTION <b>CONNECTION DIAGRAM</b> EXTERNAL - SINGLE VOLTAGE - 3Ø MOTOR			
MATERIAL		PROCESS/FINISH	
SIZE <b>A</b>	DRAWING NUMBER <b>EE7300</b>		SHEET 1 OF 1

**CERTIFICATION DATA SHEET**

Model#: 56T34F5349 D WINDING#: ZT205 FR 9  
 CONN. DIAGRAM: A-EE7300 ASSEMBLY: F1 ONLY  
 OUTLINE: A-100141-656

**TYPICAL MOTOR PERFORMANCE DATA**

HP	KW	SYNC. RPM	F.L. RPM	FRAME	ENCLOSURE	KVA CODE	DESIGN
3/4	.56	3600	3450	56C	TEFC	N	B

PH	Hz	VOLTS	FL AMPS	START TYPE	DUTY	INSL	S.F	AMB°C	ELEVATION
3	60	575	1.3	ACROSS THE LINE	CONTINUOUS	F3	1.15	40	3300

FULL LOAD EFF: 74	3/4 LOAD EFF: 68	1/2 LOAD EFF: 60	GTD. EFF	ELEC. TYPE	NO LOAD AMPS
FULL LOAD PF: 69.1	3/4 LOAD PF: 61.5	1/2 LOAD PF: 51	70	SQ CAGE IND RUN	.8

F.L. TORQUE	LOCKED ROTOR AMPS	L.R. TORQUE	B.D. TORQUE	F.L. RISE°C
1.14 LB-FT	9.2	4 LB-FT 351	5.6 LB-FT 491	50

SOUND PRESSURE @ 3 FT.	SOUND POWER	ROTOR WK^2	MAX. WK^2	SAFE STALL TIME	STARTS /HOUR	APPROX. MOTOR WGT
68 dBA	78 dBA	0.023 LB-FT^2	1.5 LB-FT^2	10 SEC.	2	22 LBS.

**\*\*\* SUPPLEMENTAL INFORMATION \*\*\***

DE BRACKET TYPE	ODE BRACKET TYPE	MOUNT TYPE	ORIENTATION	SEVERE DUTY	HAZARDOUS LOCATION	DRIP COVER	SCREENS	PAINT
C-FACE	BRAKE	BOLT-ON	HORIZONTAL OR UP OR DOWN	FALSE	NONE	PROVISIONS ONLY	NONE	GRAY (POWDER)

BEARINGS		GREASE	SHAFT TYPE	SPECIAL DE	SPECIAL ODE	SHAFT MATERIAL	FRAME MATERIAL
DE	OPE						
BALL	BALL	POLYREX EM	STANDARD 56	NONE	NONE	1144 STRESSPROOF (C-223)	ROLLED STEEL
6203	6203						

THERMO-PROTECTORS				THERMISTORS	CONTROL	SPACE /n HEATERS
THERMOSTATS	PROTECTORS	WDG RTDs	BRG RTDs			
NONE	NOT	NONE	NONE	NONE	FALSE	NONE VOLTS

If Inverter equals NONE, contact factory for further information

\*  
N  
O  
T  
E  
S  
\*

INVERTER TORQUE: NONE
INV. HP SPEED RANGE: NONE
ENCODER: NONE
NONE NONE
NONE NONE PPR
BRAKE: PROVISIONS FOR KIT NONE
NONE P/N NONE
NONE NONE
NONE FT-LB NONE V NONE Hz

DATE: 06/28/2017 02:04:51 AM  
 FORM 3531 REV.3 02/07/99

\*\* Subject to change without notice.

**Data Sheet**

Date: 1/3/2019  
 Customer: \_\_\_\_\_  
 Attention: \_\_\_\_\_  
 Submitted by: FAREEDA DUDEKULA



56T34F5349

**Submittal**

Data @ 575 V

**Motor Load Data**

Load	0%	25%	50%	75%	100%	115%	125%	LR	
Current (Amps)	0.80	0.80	0.96	1.04	1.28	1.32	1.40	9.2	
Torque (ft-lb)	0.00	0.28	0.55	0.84	1.14	1.30	1.40	4.0	
RPM	3600	3577	3560	3525	3450	3,440	3425	0	
Efficiency (%)		44.5	60.0	68.0	74.0	74.0	74.0		
P.F. (%)	18.0	37.0	51.0	61.5	69.1	74.0	75.5	74.0	

**Motor Speed Data**

	LR	Pull-Up	BD	Rated	Idle
Speed (RPM)	0	1800	2640	3450	3600
Current (Amps)	9.2	8.3	6.0	1.28	0.80
Torque (ft-lb)	4.0	3.6	5.6	1.14	0.00

**Information Block**

HP	0.8			
Sync. RPM	3600			
Frame	56			
Enclosure	TEFC			
Construction	TS			
Voltage	575 V			
Frequency	60 Hz			
Design	B			
LR Code letter	N			
Service Factor	1.15			
Temp Rise @ FL	50 °C			
Duty	CONT			
Ambient	40 °C			
Elevation	3300 feet			
Rotor/Shaft wk <sup>2</sup>	0.02 Lb-Ft <sup>2</sup>			
Ref Wdg	ZT205 FR			
Sound Pressure @ 1M	68 dBA			
VFD Rating	NONE			
Outline Dwg	A-100141-656			
Conn. Diag	A-EE7300			
Additional Specifications:				
0				
0				
EQUIV CKT (OHMS / PHASE)				
R1	R2	X1	X2	Xm
0.0000	0.0000	0.0000	0.0000	0.0000

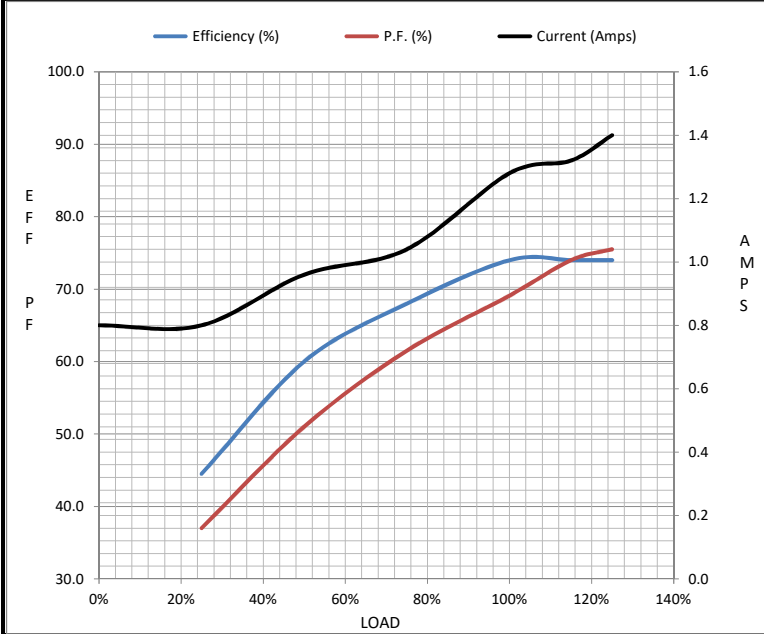

**Speed - Torque Curve**

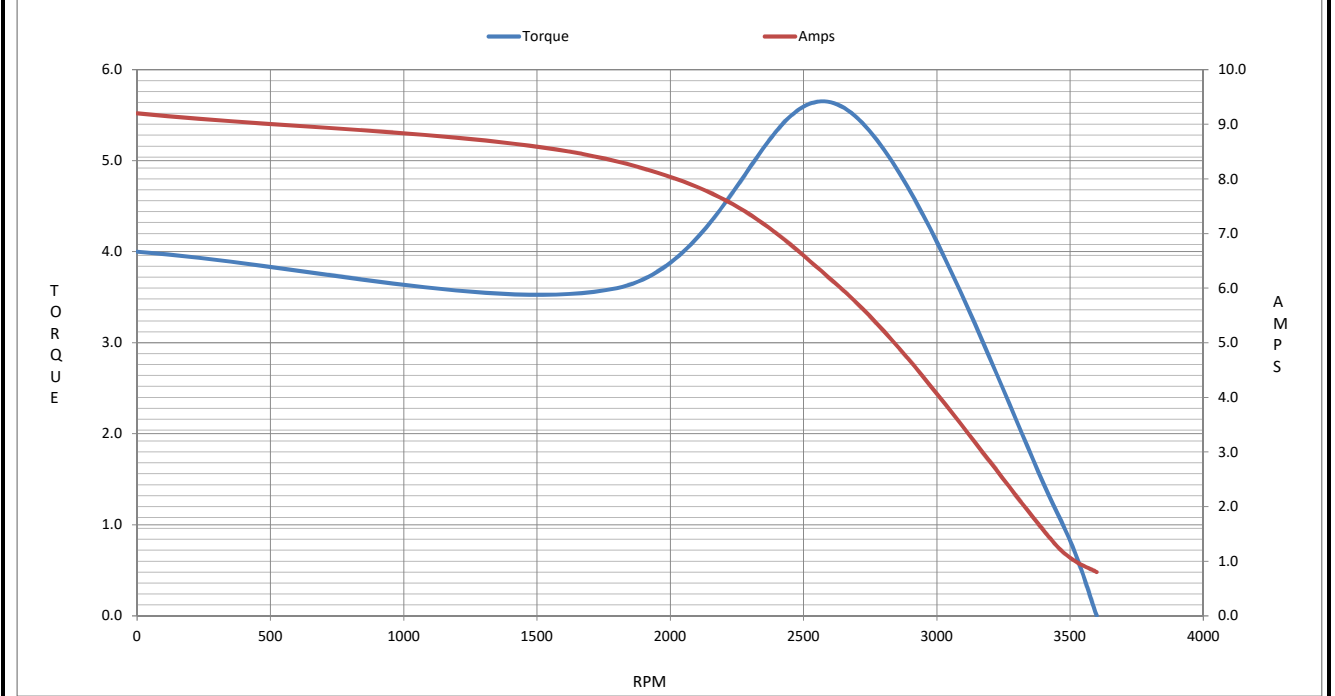

## EC Declaration of Conformity

The undersigned representing  
the manufacturer:

Regal Beloit America  
100 East Randolph St.  
Wausau, WI 54401

and the authorized representative  
established within the Community:

Marathon Electric UK  
6F Thistleton Road Ind. Estate  
Market Overton  
Oakham, Rutland LE15 7PP UK

are committed to providing customers with products that comply with applicable regulations and international protocols to which they are subject, including the requirements of the European Parliament Directive on the Harmonization of the laws relating to electrical equipment designed for use within certain voltage limits (2014/35/EU).

Regal Beloit America declares that the following product(s), to which this declaration relates, are in conformity with the relevant sections of the EC standards listed below.

This statement supersedes any statements previously issued pertaining to the product(s) listed below and is subject to change without notice.

Model No : 056T34F5349

(Model No. may contain prefix and/or suffix characters)

Catalog No : K706

Rework No : N/A

Directives :

Low Voltage Directive 2014/35/EU

Harmonized Standards Used :

EN 60034-1: 2010 (IEC 60034-1: 2010)

EN 60034-5: 2001/A1:2007 (IEC 60034-5: 2000/A1:2006)

Authorized Representative:



Michael A. Logsdon  
Vice President, Technology

Authorized Representative in the Community:



Julian Clark  
Marketing Engineer

Created on 09/01/2022

**CE 22**