

PRODUCT INFORMATION PACKET

Model No: 404TTFS16103

Catalog No: L426A

XRI® General Purpose General Purpose Motor, 50 HP, 3 Ph, 60 Hz, 460 V, 900 RPM, 404T Frame, TEFC



Regal and Marathon are trademarks of Regal Rexnord Corporation or one of its affiliated companies.
©2022 Regal Rexnord Corporation, All Rights Reserved. MC017097E

Nameplate Specifications

Output HP	50 Hp	Output KW	37.0 kW
Frequency	60 Hz	Voltage	460 V
Current	66.0 A	Speed	890 rpm
Service Factor	1.15	Phase	3
Efficiency	93.6 %	Power Factor	75.5
Duty	Continuous	Insulation Class	F
Design Code	B	KVA Code	G
Frame	404T	Enclosure	Totally Enclosed Fan Cooled
Thermal Protection	No Protection	Ambient Temperature	40 °C
Drive End Bearing Size	6316	Opp Drive End Bearing Size	6313
UL	Recognized	CSA	Y
CE	Y	IP Code	43
Number of Speeds	1		

Technical Specifications

Electrical Type	Squirrel Cage Inverter Rated	Starting Method	Line Or Inverter
Poles	8	Rotation	Reversible
Resistance Main	.1455 Ohms	Mounting	Rigid Base
Motor Orientation	Horizontal	Drive End Bearing	Ball
Opp Drive End Bearing	Ball	Frame Material	Cast Iron
Shaft Type	T	Overall Length	37.13 in
Frame Length	16.75 in	Shaft Diameter	2.875 in
Shaft Extension	7.25 in	Assembly/Box Mounting	F1/F2 CAPABLE
Inverter Load	CONSTANT 2:1		
Connection Drawing	A-EE7300	Outline Drawing	B-SS508591-1675

This is an uncontrolled document once printed or downloaded and is subject to change without notice. Date Created:11/29/2022

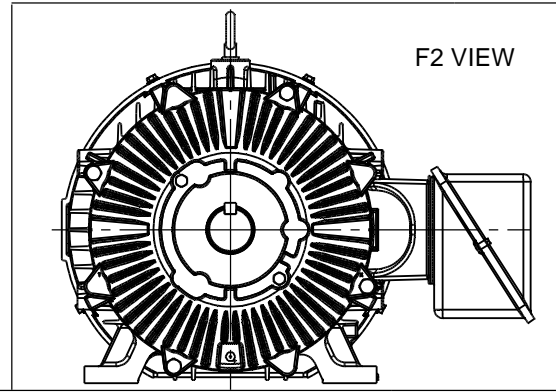
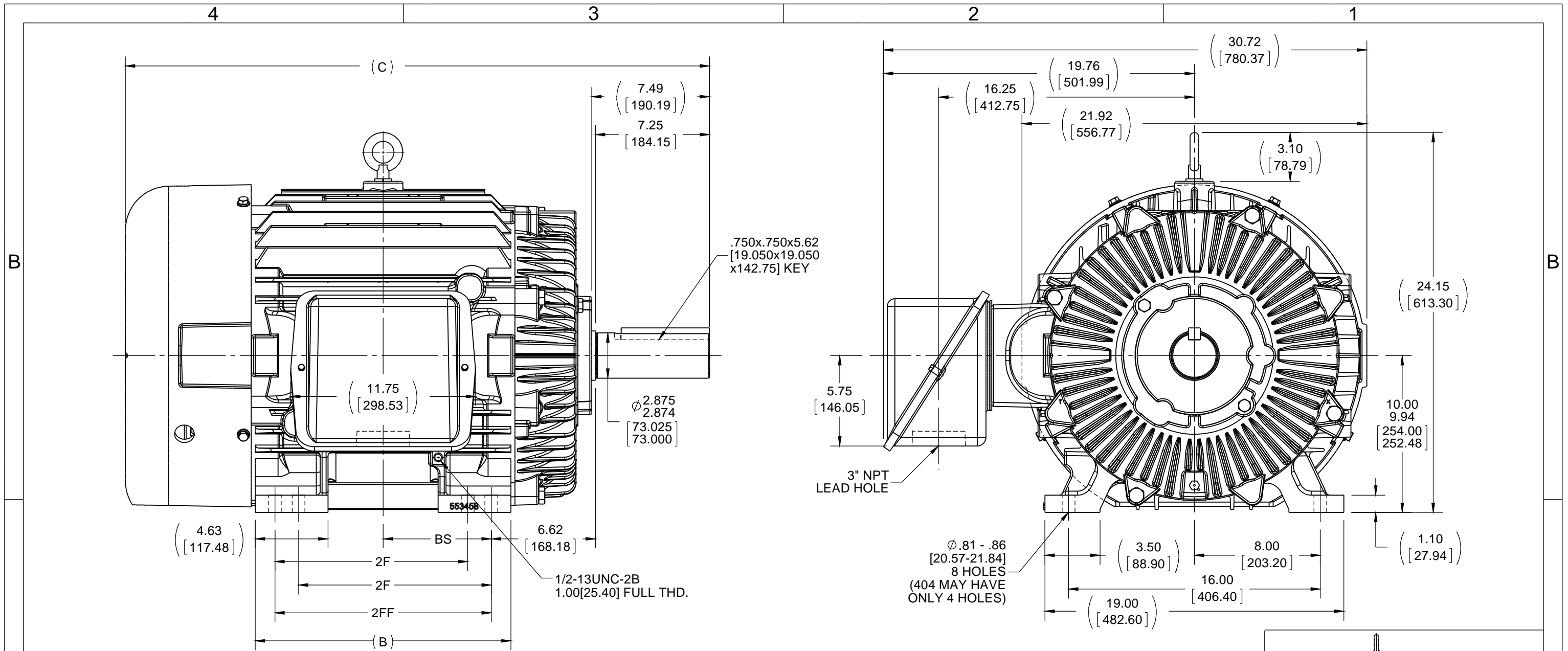

- NOTES:
1. BOX CAN BE ROTATED IN 90° STEPS.
 2. BOX CAN BE MOUNTED ON OPPOSITE SIDE BY REMOVING BRACKETS AND TURNING FRAME 180°.
 3. NAMEPLATES TO BE READ FROM CONDUIT BOX SIDE OF MOTOR.

DASH	FRAME	B	C	2F	2FF	BS
1525	404T	14.75 [374.65]	35.63 [905.00]	12.25 [311.15]	---	6.12 [155.45]
1675	404/405T	16.25 [412.75]	37.13 [943.10]	12.25 [311.15]	13.75 [349.25]	6.88 [174.75]

DRAWING REVISION C	REVISION BY AJW	DATE 11-17-2014
ECO ECO-0065341	APPROVED BY TDB	DATE 11-17-2014
ECO DESCRIPTION UPDATED TO CURRENT STANDARDS		
<small>COPYRIGHT REGAL BELOIT AMERICA, INC. ALL RIGHTS RESERVED. PROPRIETARY AND CONFIDENTIAL INFORMATION - THIS DOCUMENT IS THE PROPERTY OF REGAL BELOIT AMERICA, INC. ("OWNER") AND CONTAINS OWNER'S PROPRIETARY INFORMATION. ANY PERSON, CORPORATION OR OTHER FIRM RECEIVING IT IS DEEMED, BY RECEIVING IT, TO AGREE THAT IT, AND/OR ANY PART OF IT, SHALL NOT BE DISCLOSED TO ANY PERSON, CORPORATION OR OTHER ENTITY, DUPLICATED, AND/OR USED, EXCEPT AS EXPRESSLY APPROVED IN WRITING IN ADVANCE BY OWNER. THIS DOCUMENT SHALL BE RETURNED TO OWNER UPON REQUEST. IT MAY BE SUBJECT TO CERTAIN RESTRICTIONS UNDER APPLICABLE EXPORT CONTROL LAWS AND REGULATIONS.</small>		

TOLERANCES UNLESS OTHERWISE SPECIFIED:			
DEC.	INCH	mm	ANGLE
.X	±0.1	[±2.5]	±7° 30"
.XX	±0.03	[±0.76]	
.XXX	±0.005	[±0.127]	
.XXXX	±0.0005	[±0.0127]	
REMOVE BURRS & BREAK SHARP EDGES: .003/.015 [0.076/.381]			
CORNER FILLETS: .02 [0.51]			
MACHINED SURFACES: 200 INCH 5.1 mm			
mm SHOWN IN [BRACKETS]			

DRAWN BY TLB
DATE 05-23-1988
APPROVED BY GK
DATE 05-23-1988
REFERENCE
THIRD ANGLE PROJECTION

Regal Beloit America, Inc.	
DESCRIPTION OUTLINE 400T FR.-TEFC-TAPPED LEAD HOLE	
MATERIAL	PROCESS/FINISH
SIZE B	DRAWING NUMBER SS508591
SHEET 1 OF 1	

THREE PHASE - SINGLE VOLTAGE
MOTOR - CONDUIT BOX @ 'A'

TERMINAL BLOCK WHEN SPECIFIED

TO REVERSE ROTATION:
INTERCHANGE ANY TWO LINE
LEAD CONNECTIONS

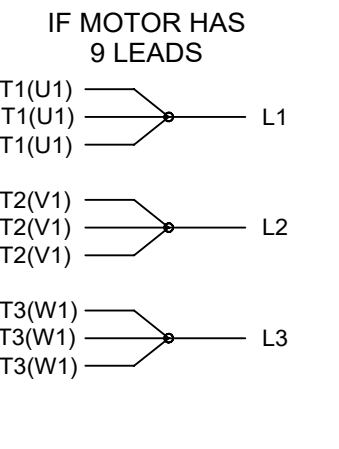

VIEW OF TERMINAL END

OPTIONAL CORD CONNECTION

L1	WHITE
L2	RED
L3	BLACK

DRAWING REVISION AC	REVISION BY BS	REV DATE/© DATE 26/07/2022
REQUEST NUMBER CR-0010402	APPROVED BY SN	DATE 26/07/2022
REQUEST NUMBER DESCRIPTION DRAWING UPDATED		
<small>COPYRIGHT (PER REVISION DATE) REGAL BELOIT AMERICA, INC. ALL RIGHTS RESERVED. PROPRIETARY AND CONFIDENTIAL INFORMATION - THIS DOCUMENT IS THE PROPERTY OF REGAL BELOIT AMERICA, INC. ("OWNER") AND CONTAINS OWNER'S PROPRIETARY INFORMATION. ANY PERSON, CORPORATION OR OTHER FIRM RECEIVING IT IS DEEMED, BY RECEIVING IT, TO AGREE THAT IT, AND/OR ANY PART OF IT, SHALL NOT BE DISCLOSED TO ANY PERSON, CORPORATION OR OTHER ENTITY, DUPLICATED, AND/OR USED, EXCEPT AS EXPRESSLY APPROVED IN WRITING IN ADVANCE BY OWNER. THIS DOCUMENT SHALL BE RETURNED TO OWNER UPON REQUEST. IT MAY BE SUBJECT TO CERTAIN RESTRICTIONS UNDER APPLICABLE EXPORT CONTROL LAWS AND REGULATIONS.</small>		

PRIMARY DIMENSIONS ARE INCH
mm DIMENSIONS IN [BRACKETS]
ARE FOR REFERENCE ONLY

DRAWN BY DA
DATE 03-26-1993
APPROVED BY TB
DATE 03-26-1993
REFERENCE
THIRD ANGLE PROJECTION

		Regal Beloit America, Inc.	
DESCRIPTION CONNECTION DIAGRAM EXTERNAL - SINGLE VOLTAGE - 3Ø MOTOR			
MATERIAL		PROCESS/FINISH	
SIZE A	DRAWING NUMBER EE7300		SHEET 1 OF 1



P.O. BOX 8003
WAUSAU, WI 54401-8003
PH. 715-675-3311

DATA VOLTS: 460

CERTIFICATION DATA SHEET

CUSTOMER: _____ CUSTOMER P.O. #: _____
 ORDER #: _____ REFERENCE MODEL #: 404TTFS16103
 CONN. DIAGRAM: A-EE7300 CAT #: L426A
 OUTLINE: B-SS508591-1675 CUSTOMER PART #: _____
 WINDING: T404816 NONE 5 MOUNTING: F1/F2 CAPABLE
 SPEED: _____

TYPICAL MOTOR PERFORMANCE DATA

HP	KW	SYNC RPM	FL RPM	FRAME	ENCLOSURE	TYPE	KVA CODE	DESIGN
50	37	900	890	404T	TEFC	TFS	G	B

PH	HZ	VOLTS	AMPS	START TYPE	DUTY	INSL	S.F.	AMB	ELEV.
3	60/50	460#380	66&63	LINE OR INVERTER	CONT	F	1.15	40	3300

F.L. EFF	93.6	3/4 LD EFF	93.6	1/2 LD EFF	93.6	GTD EFF	93.0	ELECT. TYPE	SQ CAGE INV RATED
F.L. PF	75.5	3/4 LD PF	72.0	1/2 LD PF	62.0				

F.L. TORQUE	LR AMPS @ 460 V	L.R. TORQUE	B.D. TORQUE	F.L. RISE (°C)
295 LB-FT	350	515 LB-FT 175%	625 LB-FT 212%	72

@ 3 FT.	POWER	ROTOR WK ²	MAX. LOAD WK ²	SAFE STALL TIME	STARTS/HOUR	MOTOR WGT
62 dBA	71 dBA	36.5 LB-FT ²	0 LB-FT ²	20 SEC.	0	1200 LB.

*** SUPPLEMENTAL INFORMATION ***

DE BRACKET TYPE	ODE BRACKET TYPE	MOUNT TYPE	MOTOR ORIENTATION	SEVERE DUTY	HAZARDOUS LOCATION	DRIP COVER	SCREENS	PAINT
STANDARD	STANDARD	RIGID	HORIZONTAL	NO	NONE	NO	NONE	BLUE (ENAMEL)

BEARINGS		GREASE	SHAFT TYPE	SPECIAL DE	SPECIAL ODE	SHAFT MATERIAL	FRAME MATERIAL
DE	ODE	POLYREX EM	T	NONE	NONE	1045 HOT ROLLED (C-204)	CAST IRON
BALL	BALL						
6316	6313						

THERMOSTATS	PROTECTORS	WDG RTD's	BRG RTD's	THERMISTORS	CONTROL	SPACE HEATERS
NONE	NOT	NONE	NONE	NONE	FALSE	NA

R1 (ohms/ph)	R2 (ohms/ph)	X1 (ohms/ph)	X2 (ohms/ph)	Xm (ohms/ph)	VIBRATION (in/sec)	FLOAT
0.092	0.051	0.449	0.807	7.9	0.150	ODE

* N O T E S *	INVERTER TORQUE: CONSTANT 2:1 INV. HP SPEED RANGE: NONE					
	ENCODER: NONE					
	NONE					
	NONE					
	NONE PPR					

PREPARED BY: FAREEDA DUDEKULA	BRAKE: NONE
DATE: 9/11/2018	NONE NONE
	FT-LB: NA
	VOLTAGE: NONE HZ:
FORM: 3531 REV_4 2/27/06	UL: V-INS, CONST UL REC

Data Sheet

404TTFS16103

Date: 12/3/2018
 Customer: _____
 Attention: _____
 Submitted by: FAREEDA DUDEKULA



Submittal

Data @ 460 V

Motor Load Data

Load	0%	25%	50%	75%	100%	115%	125%	LR
Current (Amps)	28.0	31.0	40.0	52.0	66.0	76.0	82.0	350
Torque (ft-lb)	0.00	73.0	147	221	295	340	370	515
RPM	900	898	895	892	890	888	885	0
Efficiency (%)		91.0	93.6	93.6	93.6	93.0	92.4	
P.F. (%)	4.0	41.0	62.0	72.0	75.5	76.5	77.0	35.5

Motor Speed Data

	LR	Pull-Up	BD	Rated	Idle
Speed (RPM)	0	450	850	890	900
Current (Amps)	350	300	200	66.0	28.0
Torque (ft-lb)	515	425	625	295	0.00

Information Block

HP	50.0			
Sync. RPM	900			
Frame	404			
Enclosure	TEFC			
Construction	TFS			
Voltage	460#380 V			
Frequency	60 Hz			
Design	B			
LR Code letter	G			
Service Factor	1.15			
Temp Rise @ FL	72 °C			
Duty	CONT			
Ambient	40 °C			
Elevation	1,000 feet			
Rotor/Shaft wk ²	36.5 Lb-Ft ²			
Ref Wdg	T404816 NONE			
Sound Pressure @ 1M	62 dBA			
VFD Rating	CONSTANT 2:1			
Outline Dwg	B-SS508591-1675			
Conn. Diag	A-EE7300			
Additional Specifications:				
0				
0				
EQUIV CKT (OHMS / PHASE)				
R1	R2	X1	X2	Xm
0.0920	0.0510	0.4490	0.8070	7.9000

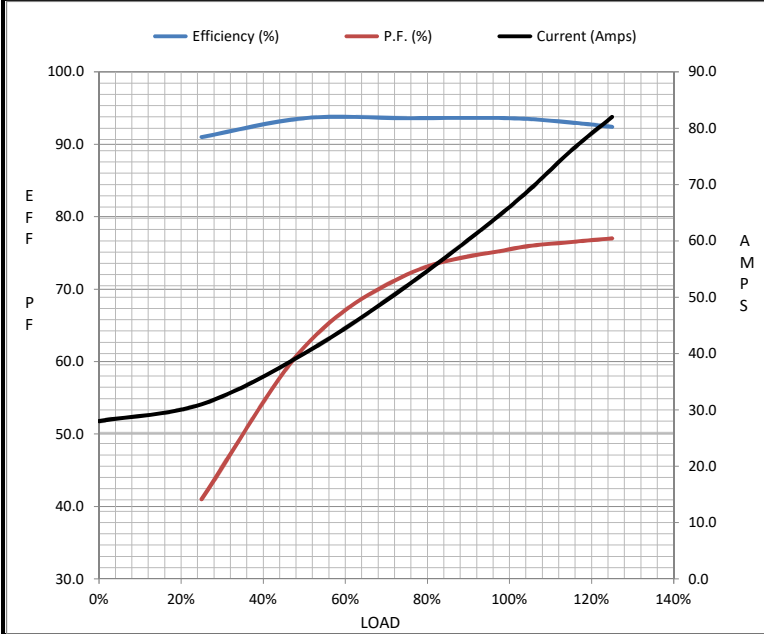

Speed - Torque Curve

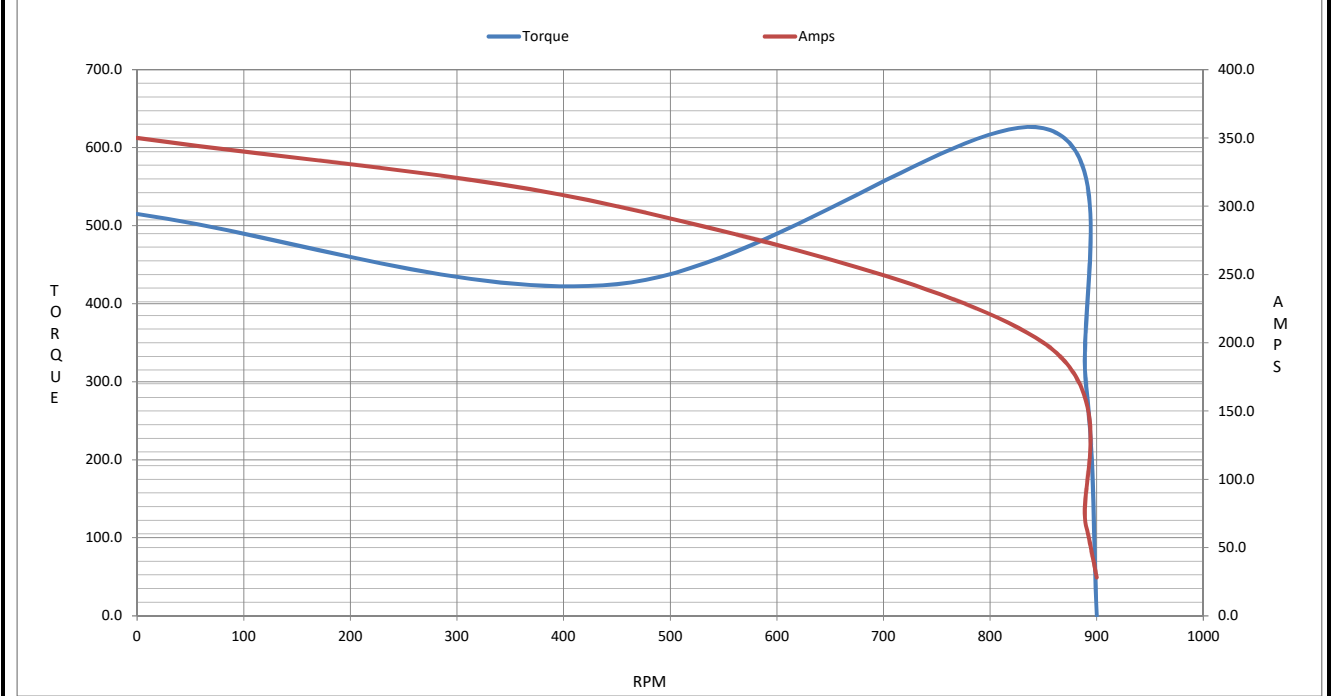

EC Declaration of Conformity

The undersigned representing
the manufacturer:

Regal Beloit America
100 East Randolph St.
Wausau, WI 54401

and the authorized representative
established within the Community:

Marathon Electric UK
6F Thistleton Road Ind. Estate
Market Overton
Oakham, Rutland LE15 7PP UK

are committed to providing customers with products that comply with applicable regulations and international protocols to which they are subject, including the requirements of the European Parliament Directive on the Harmonization of the laws relating to electrical equipment designed for use within certain voltage limits (2014/35/EU).

Regal Beloit America declares that the following product(s), to which this declaration relates, are in conformity with the relevant sections of the EC standards listed below.

This statement supersedes any statements previously issued pertaining to the product(s) listed below and is subject to change without notice.

Model No : 404TTFS16103

(Model No. may contain prefix and/or suffix characters)

Catalog No : L426A

Rework No : N/A

Directives :

Low Voltage Directive 2014/35/EU

Harmonized Standards Used :

EN 60034-1: 2010 (IEC 60034-1: 2010)

EN 60034-5: 2001/A1:2007 (IEC 60034-5: 2000/A1:2006)

Authorized Representative:



Michael A. Logsdon
Vice President, Technology

Authorized Representative in the Community:



Julian Clark
Marketing Engineer

Created on 09/01/2022

CE 22