



GE INDUSTRIAL MOTORS
a **WOLONG** company

Product Technical Information

October 11, 2022

Data shown is for the current revision model #. Ensure your nameplate model # matches.

Model Number:	5KS143BAA200
Catalog Number:	M1049
Instruction Manual:	GEI-56128
Connection Diagram:	GEM2034E-FIG3
Outline Drawing:	4002B5814GBP5202

Accessory Connection Diagrams

Bearing Thermocouple:	None	Heater:	None
RTD:	None	Thermistor:	None
Thermostat:	None	Winding Thermocouple:	None
Bearing RTD:	None		

Table of Contents

Specification	01
Performance Characteristics	02
Outline Drawing	03
Connection Drawing(s)	04
Spare parts	05

Marks:

MODEL NUMBER:	5KS143BAA200	Estimated Weight:	43 Lbs
Outline Drawing:	4002B5814GBP5202	Time Rating:	CONT
Connection Diagram:	GEM2034E-FIG3	Enclosure:	TEFC
Instruction Book:	GEI-56128	Encl Construction:	SD
Design Code:	14BD1092A	Ambient Max(°C):	40
Type:	KS	Alt Ambient Max(°C):	--
Frame:	143TC	Insulation Class:	F
Phases:	3	NEMA Design:	B
Poles:	4	Nominal Efficiency:	85.5 %
Output Power:	1HP 0.7KW	Guaranteed Efficiency:	82.5 %
RPM:	1735	3/4 Load Efficiency:	--
Voltage:	230/460	KVA Code:	N
Hertz:	60	Max KVAR:	0.7
Amps - FL:	3.2/1.6	Power Factor:	70.5
Service Factor:	1.15	Bearing - DE:	6206-2ZC3
Alt Service Factor:	--	Bearing - ODE:	6205-2ZC3

Enclosure is Totally Enclosed Fan-Cooled

Stamped Nameplate Notes:

VT 0-60 HZ NEMA MG1-31; 208V-3.1A



Additional Information:

4P - TC EXTN
STANDARD FLOOR MOUNT
C/BOX 30 CU IN-0.75 NPT
F1 CONDUIT BOX MOUNTING
"C" FACE AT DE ENDSHIELD AK=4 1/2"
INVERTER DUTY PER NEMA MG1 PART 31
ALTERNATE RATING FOR PWM CONTROL:1.0SF 40C AMBIENT
VAR TORQUE RANGE 0-60 HZ
SUITABLE FOR 208V -3.1 AMPS WITH 1.15 SF



Performance Characteristics

1st Winding 1st Connection

Design: 14BD1092A

Marks:

LOAD %	125.0	115.0	100.0	75.0	50.0	25.0	0.0
% EFF	85.48	85.65	85.9	84.94	82.06	72.51	0.00
% PF	76.81	74.65	72.4	61.65	48.5	30.38	8.26
AMPS	1.78	1.68	1.5	1.34	1.18	1.06	0.94

TORQ(FL)#FT	3	TORQ(LR)%FL	471.82	TORQ(BD)%FL	541.11
AMPS(LR)	12.69	PF AT START	0.68		

This motor is capable of two cold or one hot start with a maximum connected load inertia of 84 Lb-Ft Sq (3.54 Kg-meter Sq)at 100% voltage, where the load torque varies with the square of the speed. Acceleration time with maximum inertia and the above load type is 37 seconds. Safe stall time at 100% voltage is 82 seconds cold, 66 seconds hot. Rotor inertia is 0.08 Lb-Ft Sq (0 Kg-meter Sq).

Open Circuit A-C:	0.13	Short Circuit D-C:	0.005
Short Circuit A-C:	0.006	X/R Ratio:	1.758
Stator Slots:	36	Rotor Slots:	48

Speed Torque Current Curve (First Connection, First Speed)

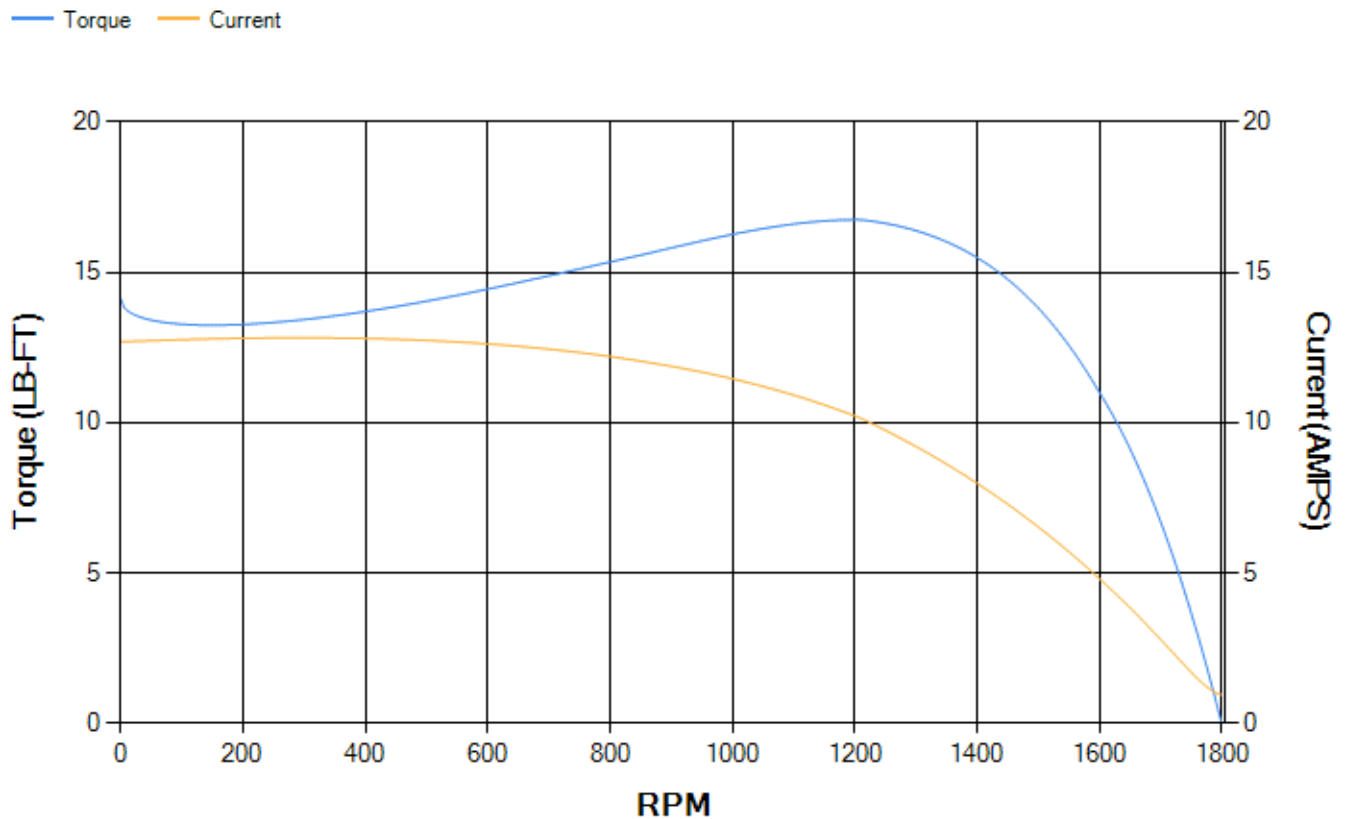

Marks:

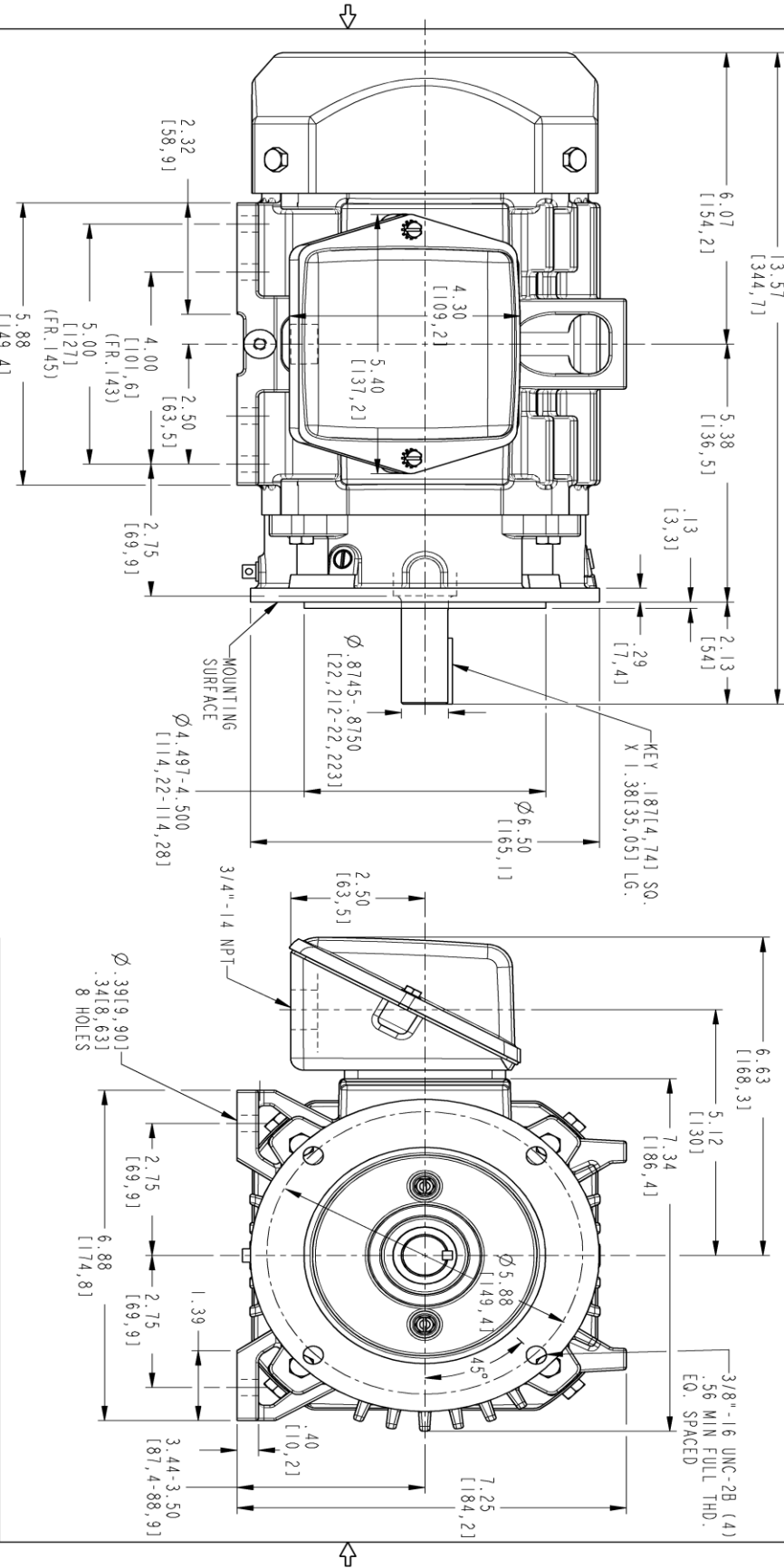

PROPRIETARY INFORMATION
 © COPYRIGHT 2018 Molong Electric America LLC AND/OR ITS AFFILIATES
 All rights reserved. This document and the information it contains is the property of Molong Electric America LLC and/or its affiliates. It has been provided solely for the use of the recipient for the specific project identified in the drawing. No other use, reproduction, distribution, or disclosure of this information is strictly prohibited except as expressly authorized in writing by Molong Electric America LLC.

SIZE DRAWING NO.	B
REV	000
SHEET	1
DESCRIPTION	INDUCTION MOTOR OUTLINE
DATE	
APPROVED	



THIRD ANGLE PROJECTION

NOTE 1: CONDUIT BOX MAY BE ASSEMBLED WITH ENTRANCE UP, DOWN OR TO EITHER SIDE.
 NOTE 2: FI ASSEMBLY AS SHOWN.
 NOTE 3: MOUNTING SURFACES WILL BE SQUARE AND CONCENTRIC WITH SHAFT WITHIN .004 T.I.R.
 NOTE 4: SHAFT RUNOUT WILL NOT EXCEED .002 T.I.R.
 NOTE 5: ALL DIMENSIONS ARE IN INCHES, BRACKETED DIMENSIONS ARE IN METRIC (MILLIMETERS).

SIGNATURES	DATE
MODEL	KALIDAS 03/12/22
DETAIL	KALIDAS 03/12/22
ORDER	KALIDAS 03/12/22
ENG	KALIDAS 03/12/22
QC	
ISSUED	KALIDAS 03/12/22
SOLID MODEL:	4002B5814GBP5202



GE INDUSTRIAL MOTORS
 INDUCTION MOTOR OUTLINE
 GP CONSTRUCTION

FR MOTC TFC C-FACE450 RABBE130 CU IN CBOX
 SIZE DRAWING
4002B5814GBP5202
 SCALE: 0.500 REF. No.: 4002B5814RBS5201

Marks:

Connection Diagram
GEM2034E-FIG3



End shield Assembly		
Part Description	DE Side Part#	ODE Side Part#
End Shield	4004D5289PA1	4004D5280SB1
Bearing	235A2602AA02	235A2600AA02
Slinger/Inproseal		

Fan & Fan Cover Assembly	
Part Description	Part#
Fan	4001A5914AM-G01
Fan Cover	4003C5808PA1

Conduit & Accessories Box Assembly	
Part Description	Part#
Conduit Box	4002B5718PX-G01

Mechanical Accessories	
Part Description	Part#
Brake	
Tachometer	

