



GE INDUSTRIAL MOTORS
a **WOLONG** company

Product Technical Information

September 8, 2022

Data shown is for the current revision model #. Ensure your nameplate model # matches.

Model Number:	5KS213BAA105
Catalog Number:	M1144
Instruction Manual:	GEI-56128
Connection Diagram:	GEM2034E-FIG3
Outline Drawing:	4002B5821GAP5201

Accessory Connection Diagrams

Bearing Thermocouple:	None	Heater:	None
RTD:	None	Thermistor:	None
Thermostat:	None	Winding Thermocouple:	None
Bearing RTD:	None		

Table of Contents

Specification	01
Performance Characteristics	02
Outline Drawing	03
Connection Drawing(s)	04
Spare parts	05

Marks:

MODEL NUMBER:	5KS213BAA105	Estimated Weight:	200 Lbs
Outline Drawing:	4002B5821GAP5201	Time Rating:	CONT
Connection Diagram:	GEM2034E-FIG3	Enclosure:	TEFC
Instruction Book:	GEI-56128	Encl Construction:	GP
Design Code:	21BD0225A	Ambient Max(°C):	40
Type:	KS	Alt Ambient Max(°C):	--
Frame:	213T	Insulation Class:	F
Phases:	3	NEMA Design:	B
Poles:	2	Nominal Efficiency:	89.5 %
Output Power:	7.5HP 5.6KW	Guaranteed Efficiency:	87.5 %
RPM:	3535	3/4 Load Efficiency:	--
Voltage:	230/460	KVA Code:	H
Hertz:	60	Max KVAR:	2.3
Amps - FL:	18.2/9.1	Power Factor:	86.5
Service Factor:	1.15	Bearing - DE:	6208-2ZC3
Alt Service Factor:	--	Bearing - ODE:	6208-2ZC3

Enclosure is Totally Enclosed Fan-Cooled

Stamped Nameplate Notes:

VT 0-60 HZ NEMA MG1-31; 208V-18.1A



Additional Information:

2P - T EXTN
STANDARD FLOOR MOUNT
C/BOX 55 CU IN-1.00 NPT
F1 CONDUIT BOX MOUNTING
INVERTER DUTY PER NEMA MG1 PART 31
ALTERNATE RATING FOR PWM CONTROL:1.0SF 40C AMBIENT
VAR TORQUE RANGE 0-60 HZ
SUITABLE FOR 208V-18.1 AMPS WITH 1.15 SF



Performance Characteristics

1st Winding 1st Connection

Design: 21BD0225A

Marks:

LOAD %	125.0	115.0	100.0	75.0	50.0	25.0	0.0
% EFF	88.69	89.16	89.91	90.08	89.17	83.96	0.00
% PF	87.94	87.53	86.44	82.69	73.94	52.88	8.85
AMPS	11.25	10.34	9.02	7.07	5.32	3.95	3.25

TORQ(FL)#FT	11.15	TORQ(LR)%FL	203.68	TORQ(BD)%FL	308.31
AMPS(LR)	60.24	PF AT START	0.36		

This motor is capable of two cold or one hot start with a maximum connected load inertia of 80 Lb-Ft Sq (3.37 Kg-meter Sq)at 100% voltage, where the load torque varies with the square of the speed. Acceleration time with maximum inertia and the above load type is 47 seconds. Safe stall time at 100% voltage is 82 seconds cold, 58 seconds hot. Rotor inertia is 0.31 Lb-Ft Sq (0.01 Kg-meter Sq).

Open Circuit A-C:	0.387	Short Circuit D-C:	0.01
Short Circuit A-C:	0.018	X/R Ratio:	3.797
Stator Slots:	36	Rotor Slots:	26

Speed Torque Current Curve (First Connection, First Speed)

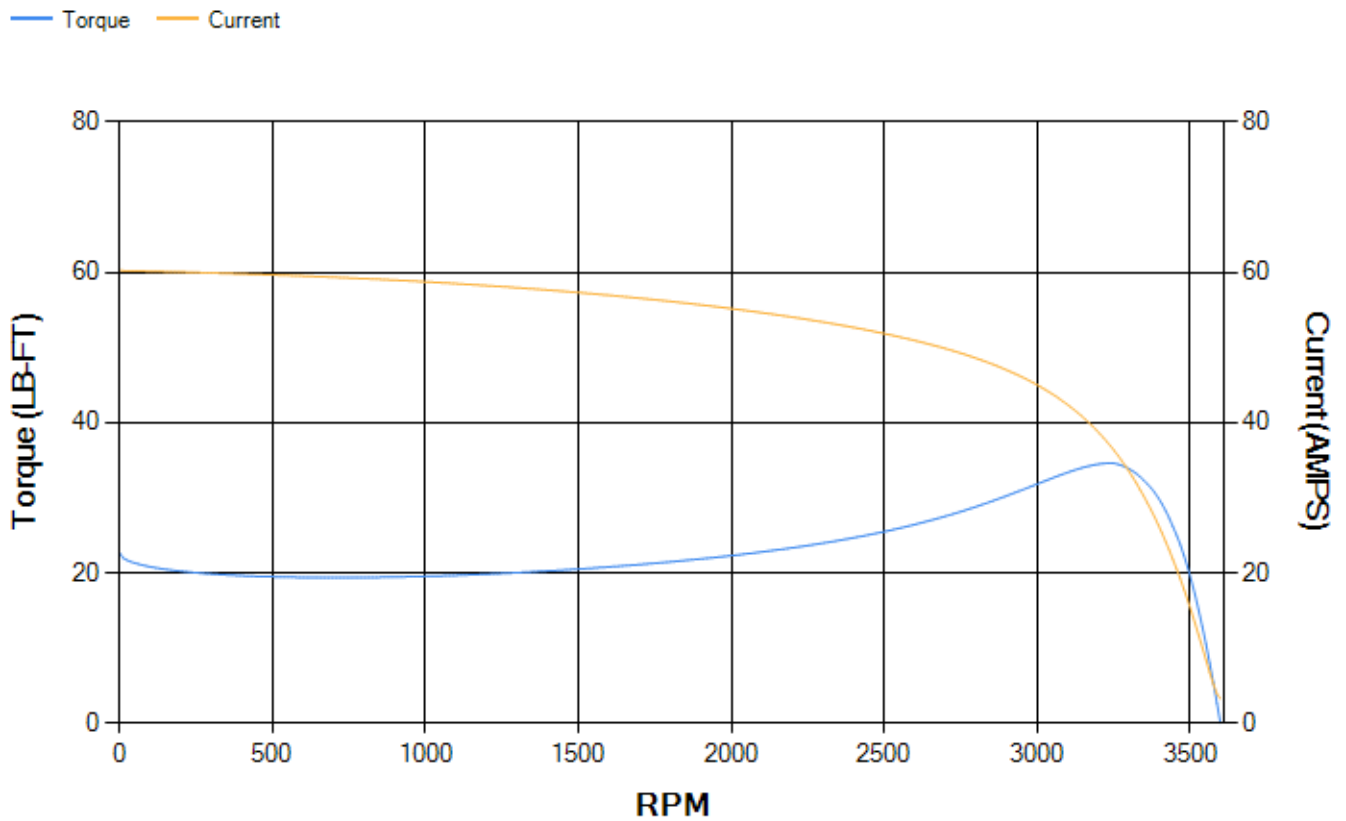

Marks:

NOTE 1: CONDUIT BOX MAY BE ASSEMBLED WITH ENTRANCE UP, DOWN OR TO EITHER SIDE.
 NOTE 2: F1 ASSEMBLY AS SHOWN.
 NOTE 3: ALL DIMENSIONS ARE IN INCHES BRACKETED DIMENSIONS ARE IN METRIC (MILLIMETERS)

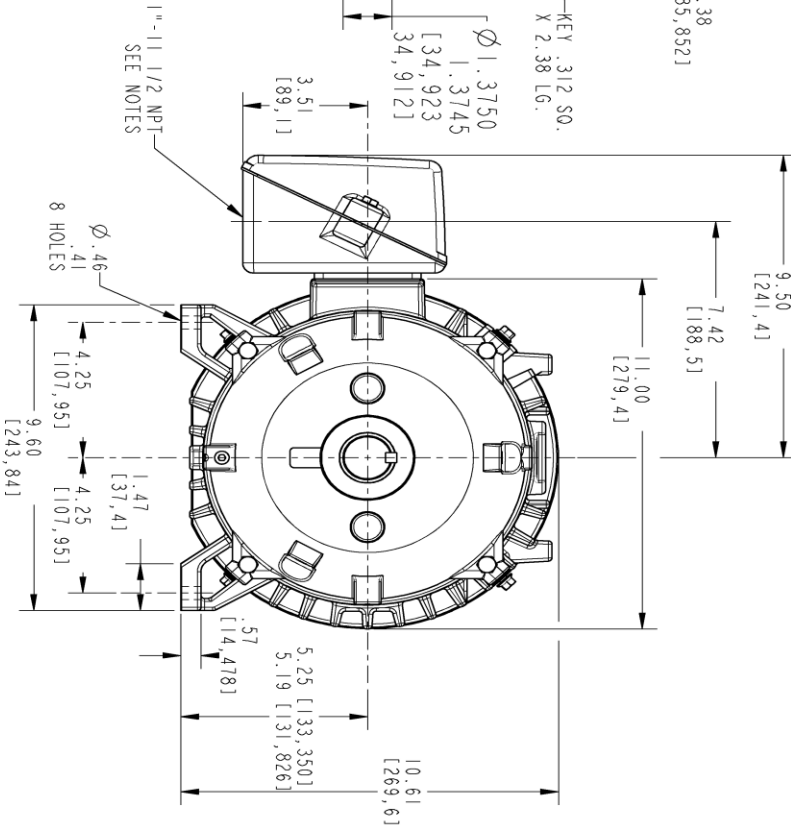
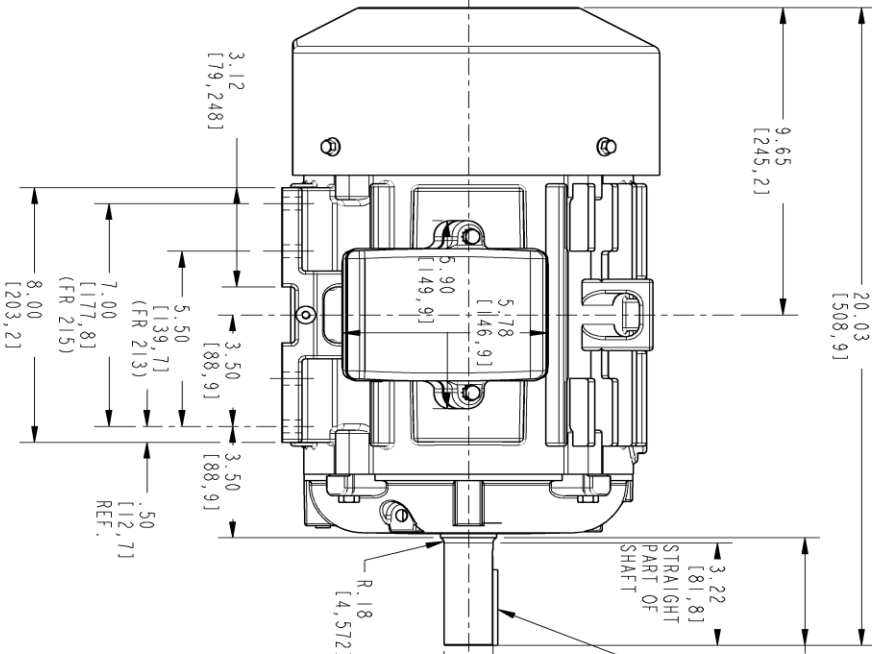

PROPRIETARY INFORMATION
 © COPYRIGHT 2018 Wologong Electric America LLC AND/OR ITS AFFILIATES.
 All rights reserved. This document and the information it contains is the property of Wologong Electric America LLC and/or its affiliates. It has been provided solely for the use of the recipient for the specific project and is not to be distributed, copied, or transmitted in any form or by any means, electronic or mechanical, including photocopying, recording, or by any information storage and retrieval system, without the express written permission of Wologong Electric America LLC. Any other use is strictly prohibited except as expressly authorized in writing by Wologong Electric America LLC.

REV.	DESCRIPTION	DATE	APPROVED

ALL DIMENSIONS ARE IN INCHES

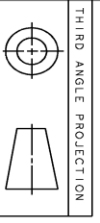

SIGNATURES		DATE	
MODEL	NARAYANA	09/24/21	
DETAIL	NARAYANA	09/24/21	
DESIGN	VILANT	09/24/21	
ENGR	DHETRAJ	09/24/21	
QC			
QUALITY			
ISSUED	NARAYANA	09/24/21	
SOLID MODEL:	4002B5821GAP5201		

TITLE		SCALE: 0.300	
INDUCTION MOTOR OUTLINE		REF. No.: 4002B5821PA2201	
GP CONSTRUCTION			
MFG: FR 29/26 T TEC			
SIZE/DRAWING	4002B5821GAP5201	REV	0
		SHEET	1 of 1



Marks:

Connection Diagram
GEM2034E-FIG3



End shield Assembly		
Part Description	DE Side Part#	ODE Side Part#
End Shield	4004D5282PA1	4004D5282SB1
Bearing	235A2603AA02	235A2603AA02
Slinger/Inproseal	149C4399G01	

Fan & Fan Cover Assembly	
Part Description	Part#
Fan	159C6704G01
Fan Cover	4003C5806PA1

Conduit & Accessories Box Assembly	
Part Description	Part#
Conduit Box	4002B5721PT-G01

Mechanical Accessories	
Part Description	Part#
Brake	
Tachometer	

