



GE INDUSTRIAL MOTORS
a **WOLONG** company

Product Technical Information

September 8, 2022

Data shown is for the current revision model #. Ensure your nameplate model # matches.

Model Number:	5KS254BAA205A
Catalog Number:	M1151
Instruction Manual:	GEI-56128
Connection Diagram:	GEM2034E-FIG9
Outline Drawing:	4002B5825GAP5201

Accessory Connection Diagrams

Bearing Thermocouple:	None	Heater:	None
RTD:	None	Thermistor:	None
Thermostat:	None	Winding Thermocouple:	None
Bearing RTD:	None		

Table of Contents

Specification	01
Performance Characteristics	02
Outline Drawing	03
Connection Drawing(s)	04
Spare parts	05

Marks:

MODEL NUMBER: 5KS254BAA205A
Outline Drawing: 4002B5825GAP5201
Connection Diagram: GEM2034E-FIG9
Instruction Book: GEI-56128
Design Code: 25BD1381A
Type: KS
Frame: 254T
Phases: 3
Poles: 4
Output Power: 15HP 11.1KW
RPM: 1775
Voltage: 230/460
Hertz: 60
Amps - FL: 37.2/18.6
Service Factor: 1.15
Alt Service Factor: --

Estimated Weight: 315 Lbs
Time Rating: CONT
Enclosure: TEFC
Encl Construction: GP
Ambient Max(°C): 40
Alt Ambient Max(°C): --
Insulation Class: F
NEMA Design: B
Nominal Efficiency: 92.4 %
Guaranteed Efficiency: 91.0 %
3/4 Load Efficiency: --
KVA Code: G
Max KVAR: 5.8
Power Factor: 81.5
Bearing - DE: 6309-2ZC3
Bearing - ODE: 6309-2ZC3

Enclosure is Totally Enclosed Fan-Cooled

Stamped Nameplate Notes:

VT 0-60 HZ NEMA MG1-31; 208V-39.5A



Additional Information:

4P - T EXTN
STANDARD FLOOR MOUNT
C/BOX 137 CU IN-1.25 NPT
F1 CONDUIT BOX MOUNTING
INVERTER DUTY PER NEMA MG1 PART 31
ALTERNATE RATING FOR PWM CONTROL:1.0SF 40C AMBIENT
VAR TORQUE RANGE 0-60 HZ
SUITABLE FOR 208V -39.5 AMPS WITH 1.15 SF



Performance Characteristics

1st Winding 1st Connection

Design: 25BD1381A

Marks:

LOAD %	125.0	115.0	100.0	75.0	50.0	25.0	0.0
% EFF	91.7	92.08	92.74	92.96	92.49	89	0.00
% PF	84.04	83.3	81.61	76.36	65.4	42.9	4.51
AMPS	22.77	21.05	18.55	14.83	11.6	9.19	8.1

TORQ(FL)#FT	44.37	TORQ(LR)%FL	206.96	TORQ(BD)%FL	273.1
AMPS(LR)	108.48	PF AT START	0.45		

This motor is capable of two cold or one hot start with a maximum connected load inertia of 496 Lb-Ft Sq (20.88 Kg-meter Sq) at 100% voltage, where the load torque varies with the square of the speed. Acceleration time with maximum inertia and the above load type is 41 seconds. Safe stall time at 100% voltage is 91 seconds cold, 60 seconds hot. Rotor inertia is 2.08 Lb-Ft Sq (0.09 Kg-meter Sq).

Open Circuit A-C:	0.412	Short Circuit D-C:	0.012
Short Circuit A-C:	0.024	X/R Ratio:	4.613
Stator Slots:	48	Rotor Slots:	40

Speed Torque Current Curve (First Connection, First Speed)

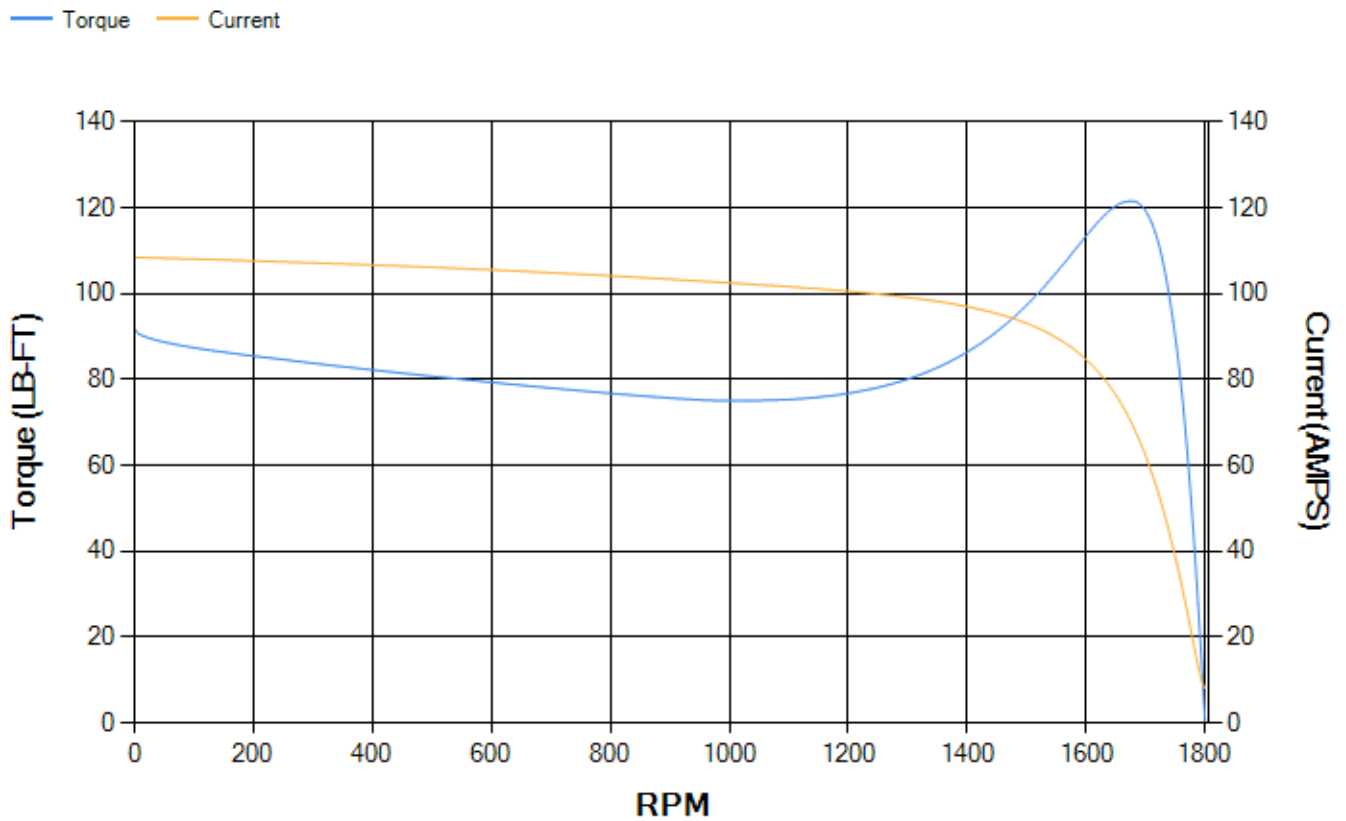

Marks:

NOTE 1: CONDUIT BOX MAY BE ASSEMBLED WITH ENTRANCE UP, DOWN OR TO EITHER SIDE.
 NOTE 2: FT ASSEMBLY AS SHOWN.
 NOTE 3: ALL DIMENSIONS ARE IN INCHES & BRACKETED DIMENSIONS ARE IN METRIC MM

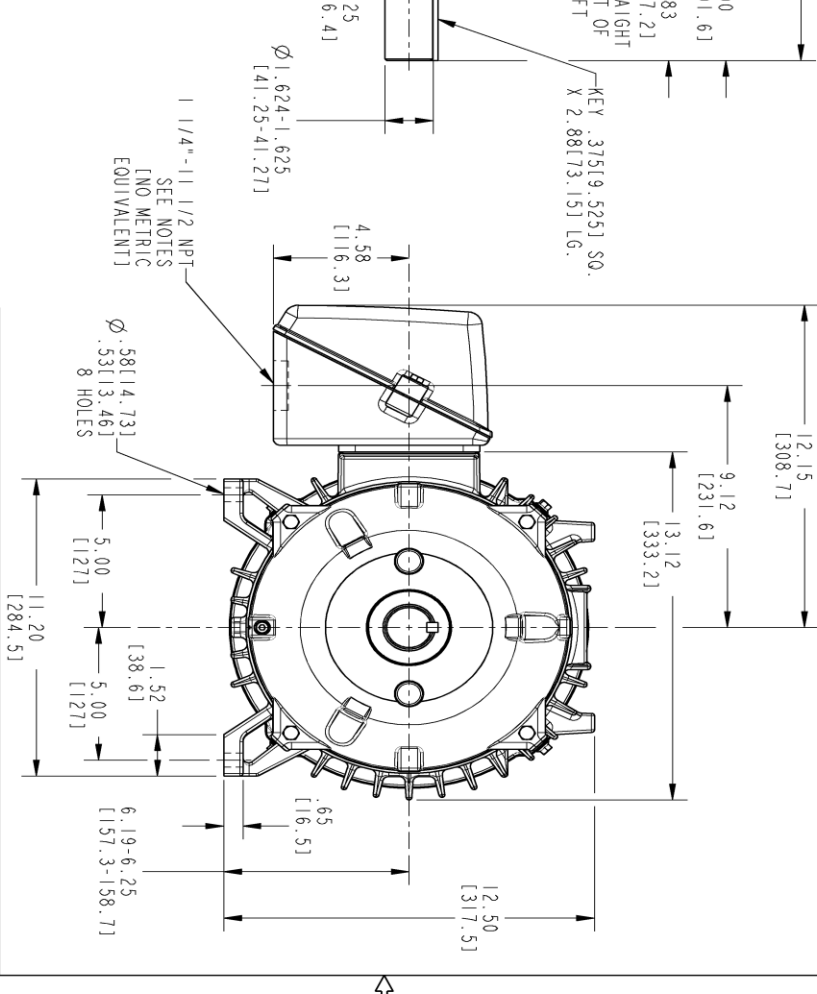
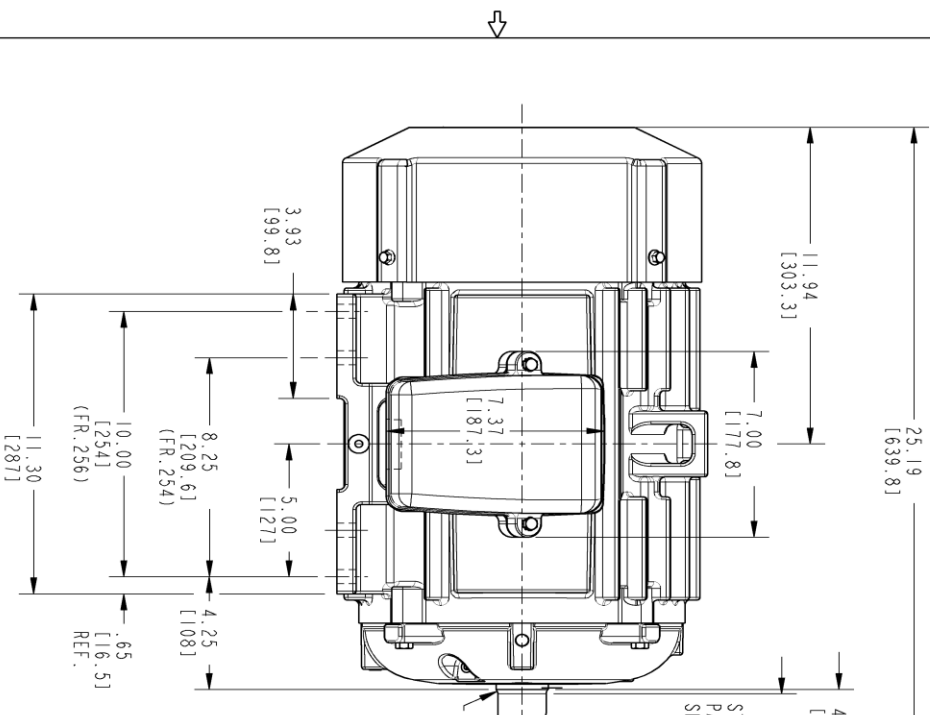

PROPRIETARY INFORMATION

© COPYRIGHT 2018 Motong Electric America LLC AND/OR ITS AFFILIATES. All rights reserved. This document and the information it contains is the property of The Motong Electric America LLC and/or its affiliates. It has been provided solely for transmission to the recipient for the specific project identified in the drawing. No other use, reproduction, or distribution of this information is strictly prohibited except as expressly authorized in writing by The Motong Electric America LLC.

REV.	DESCRIPTION	DATE	APPROVED

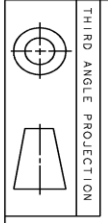

SIGNATURES	DATE
MODEL: NARAYANA [09/24/21]	
DETAIL: NARAYANA [09/24/21]	
DESIGN: VIJANT [09/24/21]	
ENGR: DHERRAJ [09/24/21]	
QC: []	
QUALITY: NARAYANA [09/24/21]	
ISSUED: []	
SOLID MODEL: 4002B5825GAP5201	

GE INDUSTRIAL MOTORS
 a WOLONG company

INDUCTION MOTOR OUTLINE
 GP CONSTRUCTION

FR 254/256 T TFC, 137 CULM C-BOX

SCALE: 0.250 REF. No.: 4002B5825GAP5201

4002B5825GAP5201

REV. 000

SHEET 1 OF 1

Marks:

Connection Diagram
GEM2034E-FIG9



End shield Assembly		
Part Description	DE Side Part#	ODE Side Part#
End Shield	4004D5283PA1	4004D5283SB1
Bearing	235A2607AA02	235A2607AA02
Slinger/Inproseal	149C4399G02	

Fan & Fan Cover Assembly	
Part Description	Part#
Fan	159C6700G02
Fan Cover	4003C5805PA1

Conduit & Accessories Box Assembly	
Part Description	Part#
Conduit Box	4002B5728SH-G04

Mechanical Accessories	
Part Description	Part#
Brake	
Tachometer	

