



**GE INDUSTRIAL MOTORS**  
a **WOLONG** company

# Product Technical Information

September 8, 2022

Data shown is for the current revision model #. Ensure your nameplate model # matches.

<b>Model Number:</b>	<b>5KS286BAA305</b>
<b>Catalog Number:</b>	<b>M1155</b>
<b>Instruction Manual:</b>	GEI-56128
<b>Connection Diagram:</b>	GEM2034E-FIG9
<b>Outline Drawing:</b>	4002B5828GAP5201

## Accessory Connection Diagrams

<b>Bearing Thermocouple:</b>	None	<b>Heater:</b>	None
<b>RTD:</b>	None	<b>Thermistor:</b>	None
<b>Thermostat:</b>	None	<b>Winding Thermocouple:</b>	None
<b>Bearing RTD:</b>	None		

## Table of Contents

Specification	01
Performance Characteristics	02
Outline Drawing	03
Connection Drawing(s)	04
Spare parts	05

Marks:

<b>MODEL NUMBER:</b>	<b>5KS286BAA305</b>
Outline Drawing:	4002B5828GAP5201
Connection Diagram:	GEM2034E-FIG9
Instruction Book:	GEI-56128
Design Code:	28BD3094A
Type:	KS
Frame:	286T
Phases:	3
Poles:	6
Output Power:	20HP 14.8KW
RPM:	1180
Voltage:	230/460
Hertz:	60
Amps - FL:	52.4/26.2
Service Factor:	1.15
Alt Service Factor:	--

<b>Estimated Weight:</b>	510 Lbs
<b>Time Rating:</b>	CONT
<b>Enclosure:</b>	TEFC
<b>Encl Construction:</b>	GP
<b>Ambient Max(°C):</b>	40
<b>Alt Ambient Max(°C):</b>	--
<b>Insulation Class:</b>	F
<b>NEMA Design:</b>	B
<b>Nominal Efficiency:</b>	91.7 %
<b>Guaranteed Efficiency:</b>	90.2 %
<b>3/4 Load Efficiency:</b>	--
<b>KVA Code:</b>	G
<b>Max KVAR:</b>	8.6
<b>Power Factor:</b>	78.0
<b>Bearing - DE:</b>	6310-2ZC3
<b>Bearing - ODE:</b>	6310-2ZC3

Enclosure is Totally Enclosed Fan-Cooled

---

Stamped Nameplate Notes:

VT 0-60 HZ NEMA MG1-31; 208V-55.4A



**Additional Information:**

6P - T EXTN  
STANDARD FLOOR MOUNT  
C/BOX 137 CU IN-1.50 NPT  
F1 CONDUIT BOX MOUNTING  
INVERTER DUTY PER NEMA MG1 PART 31  
ALTERNATE RATING FOR PWM CONTROL:1.0SF 40C AMBIENT  
VAR TORQUE RANGE 0-60 HZ  
SUITABLE FOR 208V -55.4 AMPS WITH 1.15 SF



**Performance Characteristics**

1st Winding 1st Connection

**Design: 28BD3094A**

**Marks:**

LOAD %	125.0	115.0	100.0	75.0	50.0	25.0	0.0
% EFF	90.76	91.25	92.05	92.43	92.06	88.54	0.00
% PF	80.29	79.61	77.9	72.43	61.17	39.32	4.16
AMPS	32.11	29.63	26.12	20.97	16.62	13.44	12.04

<b>TORQ(FL)#FT</b>	88.9	<b>TORQ(LR)%FL</b>	157.11	<b>TORQ(BD)%FL</b>	264.08
<b>AMPS(LR)</b>	142.83	<b>PF AT START</b>	0.36		

This motor is capable of two cold or one hot start with a maximum connected load inertia of 1029 Lb-Ft Sq (43.32 Kg-meter Sq)at 100% voltage, where the load torque varies with the square of the speed. Acceleration time with maximum inertia and the above load type is 35 seconds. Safe stall time at 100% voltage is 89 seconds cold, 52 seconds hot. Rotor inertia is 6.1 Lb-Ft Sq (0.26 Kg-meter Sq).

<b>Open Circuit A-C:</b>	0.346	<b>Short Circuit D-C:</b>	0.013
<b>Short Circuit A-C:</b>	0.026	<b>X/R Ratio:</b>	4.937
<b>Stator Slots:</b>	54	<b>Rotor Slots:</b>	42

**Speed Torque Current Curve (First Connection, First Speed)**

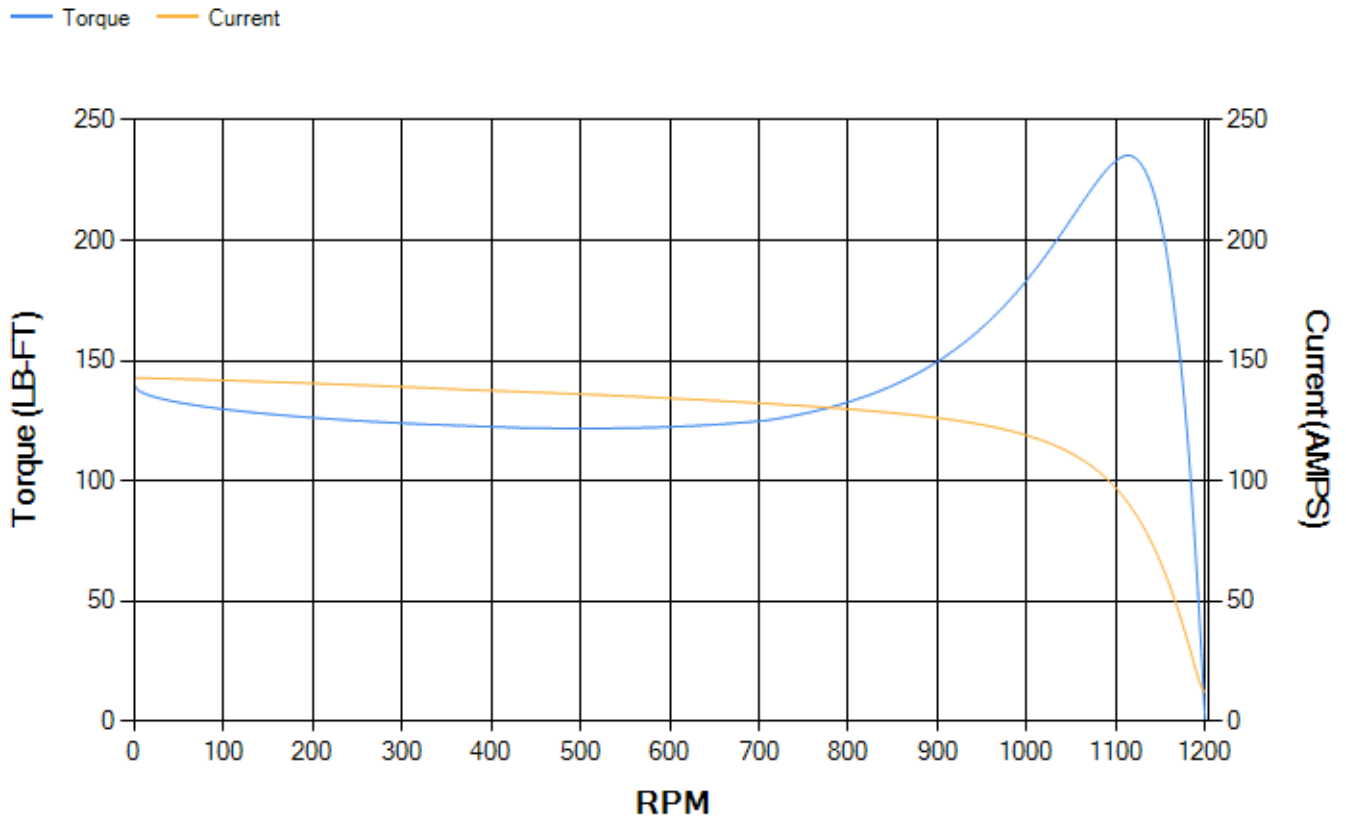

Marks:

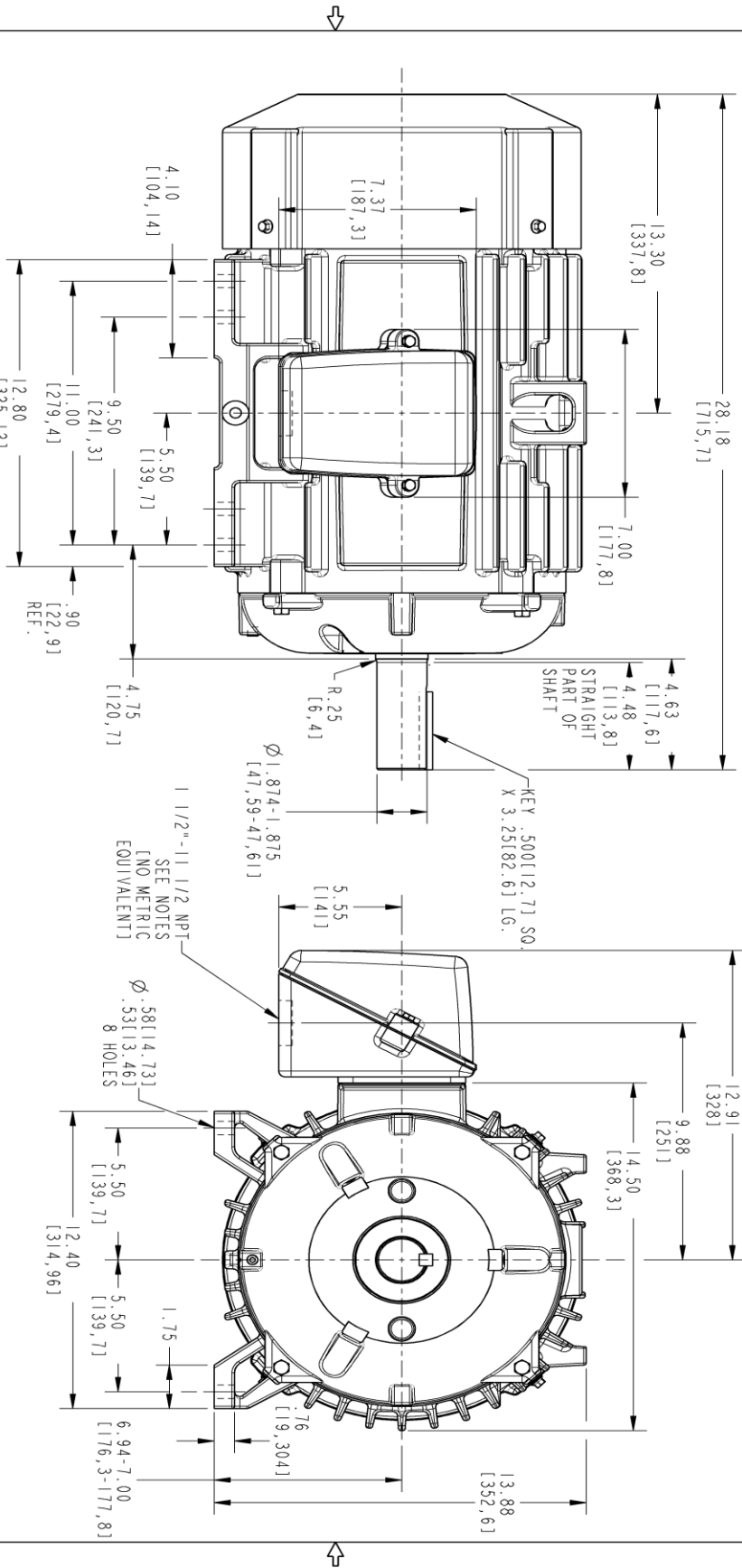

NOTE 1: CONDUIT BOX MAY BE ASSEMBLED WITH ENTRANCE UP, DOWN OR TO EITHER SIDE.  
 NOTE 2: FIT ASSEMBLY AS SHOWN.  
 NOTE 3: ALL DIMENSIONS ARE IN INCHES AND BRACKETED DIMENSIONS ARE IN METRIC mm

PROPRIETARY INFORMATION  
 © COPYRIGHT 2018 Wolog Electric America LLC AND/OR ITS AFFILIATES.  
 All rights reserved. This document and the information it contains is the property of Wolog Electric America LLC and/or its affiliates. It has been provided solely for transmission, use, copying, or recording, and any other use, reproduction, or distribution is strictly prohibited except as expressly authorized in writing by Wolog Electric America LLC.

SIZE	DRAWING NO.	REV	SHEET
B	4002B58286GAP5201	000	1
REVISIONS			
REV.	DESCRIPTION	DATE	APPROVED



THIRD ANGLE PROJECTION

SIGNATURES	DATE
MODEL: NARAYANA [09/24/21]	
DETAIL: NARAYANA [09/24/21]	
DESIGN: VIJANT [09/24/21]	
ENGR: DHETRAJ [09/24/21]	
QC: NARAYANA [09/24/21]	
ISSUED: NARAYANA [09/24/21]	
SOLID MODEL: 4002B58286GAP5201	
 <b>GE INDUSTRIAL MOTORS</b> a Wolog company	
<b>INDUCTION MOTOR OUTLINE</b> GP CONSTRUCTION	
284/286 T TEFC GP ULTRA 137 CU IN CBOX	
SCALE: 0.250	REF. No.: 4002B58286GAP5201
SHEET DRAWING	REV
<b>4002B58286GAP5201</b>	<b>000</b>
SHEET 1 OF 1	

Marks:

**Connection Diagram**  
**GEM2034E-FIG9**



End shield Assembly		
Part Description	DE Side Part#	ODE Side Part#
End Shield	4004D5284PA1	4004D5284SB1
Bearing	235A2608AA02	235A2608AA02
Slinger/Inproseal	149C4399G03	

Fan & Fan Cover Assembly	
Part Description	Part#
Fan	159C6900G01
Fan Cover	4003C5799PA1

Conduit & Accessories Box Assembly	
Part Description	Part#
Conduit Box	4002B5728SH-G01

Mechanical Accessories	
Part Description	Part#
Brake	
Tachometer	

