



GE INDUSTRIAL MOTORS
a **WOLONG** company

Product Technical Information

May 2, 2023

Data shown is for the current revision model #. Ensure your nameplate model # matches.

Model Number:	5KS324BAA115
Catalog Number:	M1162
Instruction Manual:	GEI-56128
Connection Diagram:	GEM2034E-FIG9
Outline Drawing:	239CG000AA

Accessory Connection Diagrams

Bearing Thermocouple:	None	Heater:	None
RTD:	None	Thermistor:	None
Thermostat:	None	Winding Thermocouple:	None
Bearing RTD:	None		

Table of Contents

Specification	01
Performance Characteristics	02
Outline Drawing	03
Connection Drawing(s)	04
Spare parts	05

Marks:

MODEL NUMBER:	5KS324BAA115	Estimated Weight:	620 Lbs
Outline Drawing:	239CG000AA	Time Rating:	CONT
Connection Diagram:	GEM2034E-FIG9	Enclosure:	TEFC
Instruction Book:	GEI-56128	Encl Construction:	GP
Design Code:	32BD0110A	Ambient Max(°C):	40
Type:	KS	Alt Ambient Max(°C):	--
Frame:	324TS	Insulation Class:	F
Phases:	3	NEMA Design:	B
Poles:	2	Nominal Efficiency:	93.0 %
Output Power:	40HP 29.6KW	Guaranteed Efficiency:	--
RPM:	3565	3/4 Load Efficiency:	--
Voltage:	230/460	KVA Code:	G
Hertz:	60	Max KVAR:	15.5
Amps - FL:	97.6/48.8	Power Factor:	82.5
Service Factor:	1.15	Bearing - DE:	6210ZC3
Alt Service Factor:	--	Bearing - ODE:	6210ZC3

Enclosure is Totally Enclosed Fan-Cooled

Stamped Nameplate Notes:

VT 0-60 HZ NEMA MG1-31



Additional Information:

2P - TS EXTN
C/BOX 346 CU IN - 3.00" NPT
F1 MOUNTING
INVERTER DUTY PER NEMA MG1 PART 31
ALTERNATE RATING FOR PWM CONTROL:1.0SF 40C AMBIENT
VAR TORQUE RANGE 0-60 HZ



Performance Characteristics

1st Winding 1st Connection

Design: 32BD0110A

Marks:

LOAD %	125.0	115.0	100.0	75.0	50.0	25.0	0.0
% EFF	92.47	92.67	93.06	92.79	91.69	86.97	0.00
% PF	84.8	84.01	82.26	76.97	66.05	43.76	5.58
AMPS	59.68	55.3	48.84	39.31	30.91	24.59	21.61

TORQ(FL)#FT	58.88	TORQ(LR)%FL	145.5	TORQ(BD)%FL	296.11
AMPS(LR)	300.43	PF AT START	0.29		

This motor is capable of two cold or one hot start with a maximum connected load inertia of 117 Lb-Ft Sq (4.93 Kg-meter Sq)at 100% voltage, where the load torque varies with the square of the speed. Acceleration time with maximum inertia and the above load type is 23 seconds. Safe stall time at 100% voltage is 52 seconds cold, 27 seconds hot. Rotor inertia is 3.11 Lb-Ft Sq (0.13 Kg-meter Sq).

Open Circuit A-C:	0.598	Short Circuit D-C:	0.017
Short Circuit A-C:	0.041	X/R Ratio:	6.428
Stator Slots:	48	Rotor Slots:	38

Speed Torque Current Curve (First Connection, First Speed)

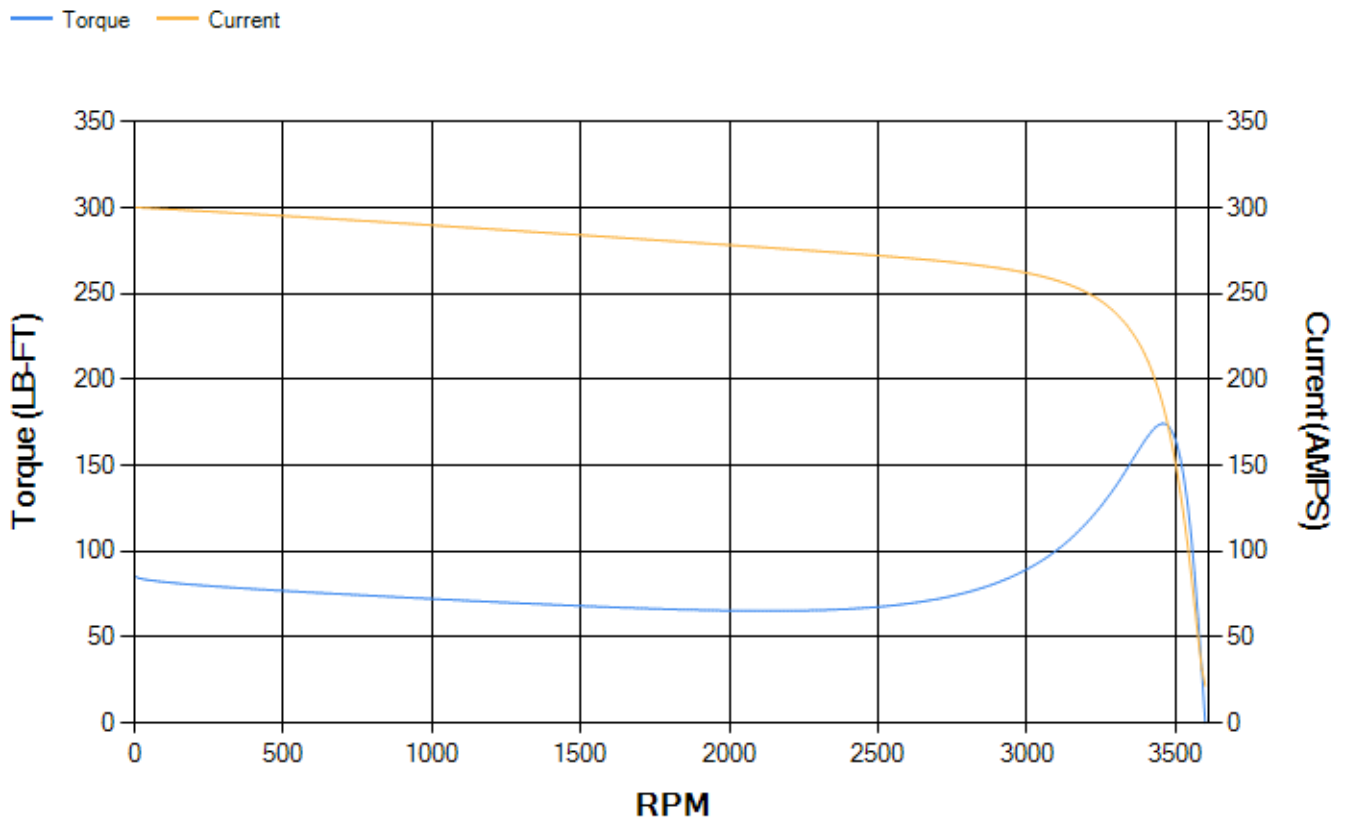

Marks:

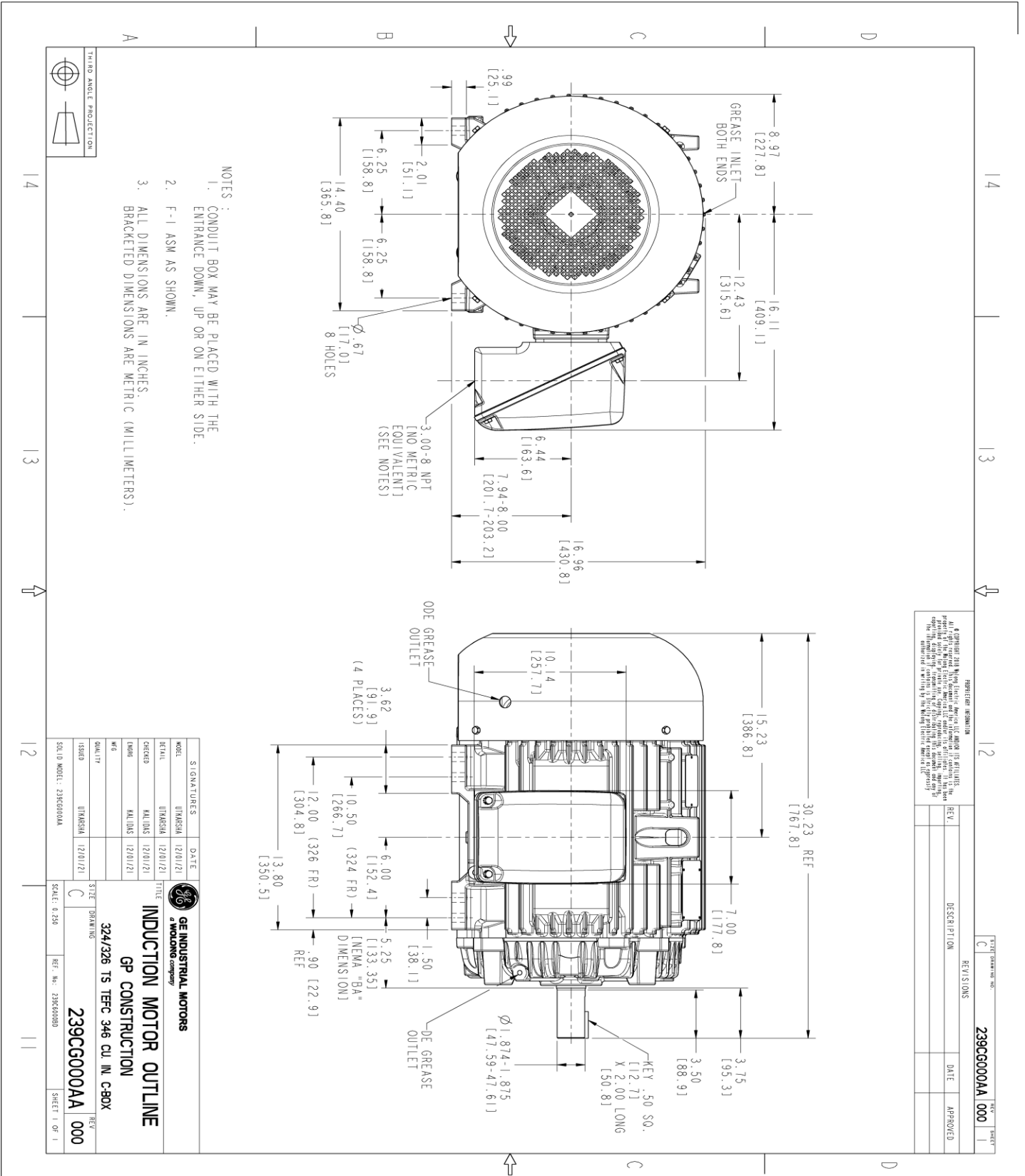

- NOTES :
- CONDUIT BOX MAY BE PLACED WITH THE ENTRANCE DOWN, UP OR ON EITHER SIDE.
 - F-1 ASM AS SHOWN.
 - ALL DIMENSIONS ARE IN INCHES. BRACKETED DIMENSIONS ARE METRIC (MILLIMETERS).

Marks:

Connection Diagram
GEM2034E-FIG9

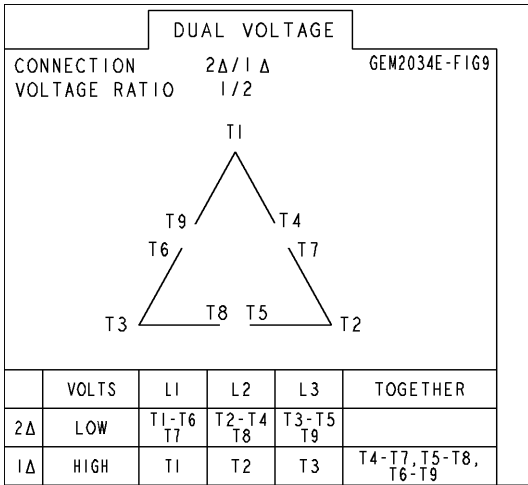

End shield Assembly		
Part Description	DE Side Part#	ODE Side Part#
End Shield	115E4201AA1	115E4201ZA1
Bearing	235A2610AA01	235A2610AA01
Slinger/Inproseal	149C4399G03	

Fan & Fan Cover Assembly	
Part Description	Part#
Fan	159C6700G02
Fan Cover	128D6854AA1

Conduit & Accessories Box Assembly	
Part Description	Part#
Conduit Box	149C4429AA2

Mechanical Accessories	
Part Description	Part#
Brake	
Tachometer	

