



GE INDUSTRIAL MOTORS
a **WOLONG** company

Product Technical Information

June 23, 2020

Data shown is for the current revision model #. Ensure your nameplate model # matches.

Model Number:	5KS143XAA304D1
Catalog Number:	M355
Instruction Manual:	GEI-56128
Connection Diagram:	GEM2034E-FIG1
Outline Drawing:	4002B5814PAP5311

Accessory Connection Diagrams

Bearing Thermocouple:	None	Heater:	None
RTD:	None	Thermistor:	None
Thermostat:	None	Winding Thermocouple:	None
Bearing RTD:	None		

Table of Contents

Specification	01
Performance Characteristics	02
Outline Drawing	03
Connection Drawing(s)	04
Spare parts	05

Marks:

MODEL NUMBER:	5KS143XAA304D1	Estimated Weight:	43 Lbs
Outline Drawing:	4002B5814PAP5311	Time Rating:	CONT
Connection Diagram:	GEM2034E-FIG1	Enclosure:	TEFC
Instruction Book:	GEI-56128	Encl Construction:	841
Design Code:	14BD3015BA	Ambient Max(°C):	40
Type:	KS	Alt Ambient Max(°C):	--
Frame:	143T	Insulation Class:	H
Phases:	3	NEMA Design:	B
Poles:	6	Nominal Efficiency:	77 %
Output Power:	0.75HP 0.6KW	Guaranteed Efficiency:	75.5 %
RPM:	1155	3/4 Load Efficiency:	77.2 %
Voltage:	575	KVA Code:	P
Hertz:	60	Max KVAR:	0.8
Amps - FL:	1.3	Power Factor:	57.0
Service Factor:	1.15	Bearing - DE:	6205ZC3
Alt Service Factor:	--	Bearing - ODE:	6205ZC3

Enclosure is Totally Enclosed Fan-Cooled

Stamped Nameplate Notes:

IEEE-STD-841-2009
 DE BRG 25BC02JP30 ODE BRG 25BC02JP30
 STAMP NP249A5564P051 AS BELOW:
 MODEL:5KS143XAA304D1 S/N: XXX
 CSA CERTIFIED CSA09.2216219 FOR EX NA IIC 200C GC
 CL 1 ZONE2 AEX NA IIC 200C;CL 1 DIV2 GRP ABCD 200C
 IN -25C <= AMB <= 40C, 1.0 SF ON SINE-WAVE PWR
 SURF TEMP 200C AT 1.15SF ON SINE-WAVE PWR
 OR 200 C VT OR 200 C CT OR 200 C CHP PWM CONTROL
 ALTERNATE RATING FOR PWM CONTROL 1.0SF 40C AMB
 VT 0-60 HZ, CT 3-60 HZ, CHP 60-90 HZ.

Additional Information:

6P - T EXTN
 STANDARD FLOOR MOUNT
 C/BOX 30 CU IN-0.75 NPT
 F1 CONDUIT BOX MOUNTING
 PAINTED FRAME ID & SHAFT,
 FAN COVER INSIDE & ODE E/S OUTSIDE
 ROUTINE AND 5 POINT VIBRATION TESTS INCL IN C/BOX
 INPRO SEAL BOTH ENDS
 GROUND SCREW ON FRAME
 SHAFT RUNOUT LIMIT .001" TIR
 COPPER WASHER UNDER HEADS OF BEARING CAP BOLTS
 APPLY TITE-SEAL (A50CD427A) ON BEARING CAP SCREWS, RABBETS,
 AND PLUG THREADS
 OIL RESISTANT SLEEVING ON LEADS





Performance Characteristics

1st Winding 1st Connection

Design: 14BD3015BA

Marks:

LOAD %	125.0	115.0	100.0	75.0	50.0	25.0	0.0
% EFF	78.18	78.42	78.64	77.17	72.88	60.27	0.00
% PF	64.37	61.67	58.94	47.74	36.31	23.1	8.64
AMPS	1.39	1.34	1.21	1.14	1.06	1.01	0.93

TORQ(FL)#FT	3.41	TORQ(LR)%FL	339.15	TORQ(BD)%FL	390.88
AMPS(LR)	6.27	PF AT START	0.65		

This motor is capable of two cold or one hot start with a maximum connected load inertia of 132 Lb-Ft Sq (5.56 Kg-meter Sq)at 100% voltage, where the load torque varies with the square of the speed. Acceleration time with maximum inertia and the above load type is 48 seconds. Safe stall time at 100% voltage is 106 seconds cold, 77 seconds hot. Rotor inertia is 0.07 Lb-Ft Sq (0 Kg-meter Sq).

Open Circuit A-C:	0.064	Short Circuit D-C:	0.005
Short Circuit A-C:	0.006	X/R Ratio:	1.806
Stator Slots:	36	Rotor Slots:	48

Speed Torque Current Curve (First Connection, First Speed)

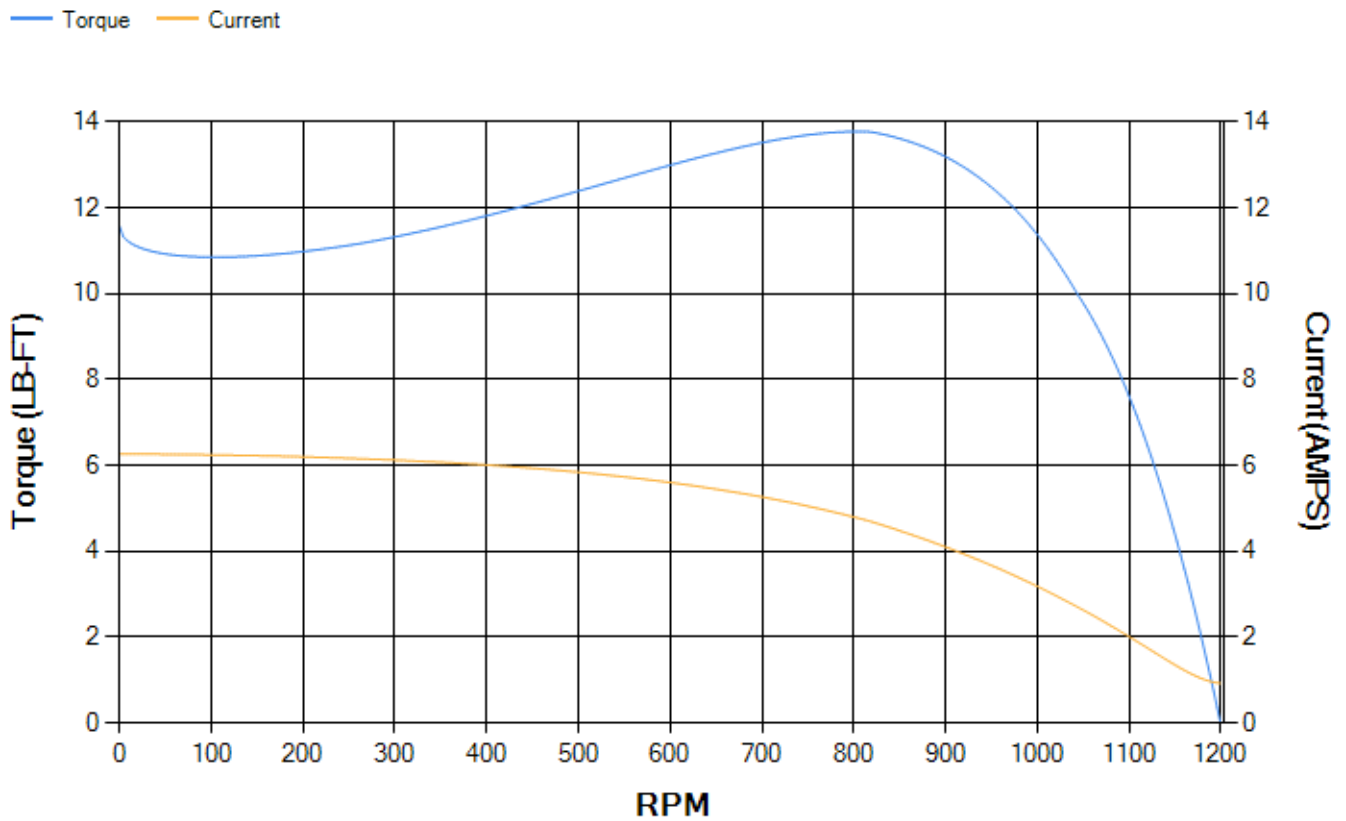

Marks:

NOTE 1: CONDUIT BOX MAY BE ASSEMBLED WITH ENTRANCE UP, DOWN OR TO EITHER SIDE.
 NOTE 2: F1 ASSEMBLY AS SHOWN. F2 ASSEMBLY CONDUIT BOX ON OPPOSITE SIDE FROM SHOWN LOCATION.
 NOTE 3: SHAFT RUNOUT WILL NOT EXCEED .001 T. I. R.
 NOTE 4: ALL DIMENSIONS ARE IN INCHES, BRACKETED DIMENSIONS ARE IN METRIC (MILLIMETERS).

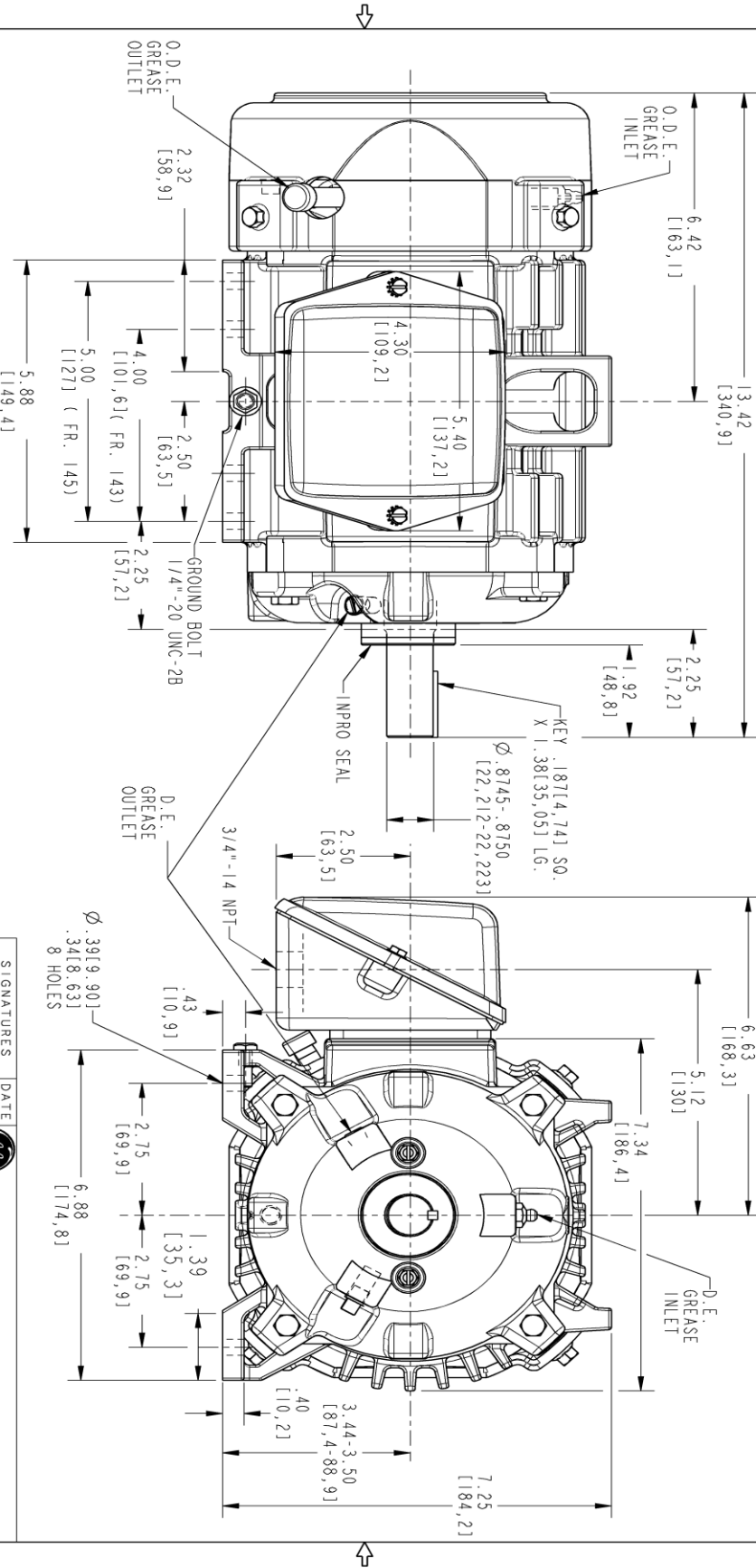

PROPRIETARY INFORMATION
 © COPYRIGHT 2018 Wolog Electric America LLC AND/OR ITS AFFILIATES
 All rights reserved. This document and the information it contains is the property of the Wolog Electric America LLC and/or its affiliates. It has been provided solely for transmission to the recipient for their use only. No other use, reproduction, or distribution is strictly prohibited except as expressly authorized in writing by the Wolog Electric America LLC.

REV.	DESCRIPTION	DATE	APPROVED
1	ISAC# 15-0944	HARIKIRAN 09/24/15	SAGAR
2	ISAC# 18-0869	SREEDevi 10/23/18	PRASHANTH
3	ISAC# 20-0411	21/04/20	DHEERAJ

SIZE	DRAWING NO.	REV	SHEET
B	4002B5814PAP5311	003	1

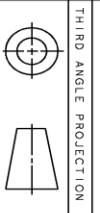

SIGNATURES		DATE
TEJASNI	TEJASNI	06/03/15
DETAIL	TEJASNI	06/03/15
DESIGN	MARTIN	06/03/15
ENG	VENKAT	06/03/15
QUALITY	TEJASNI	06/03/15
ISSUED	B	
SCALE: 0.500 REF. No.: 4002B5814PAP5311		



INDUCTION MOTOR OUTLINE
 STANDARD CONSTRUCTION FOR IEEE-841 SPEC
 FME: FR140T TFC

SIZE	DRAWING	REV
B	4002B5814PAP5311	003
SHEET 1 OF 1		

Marks:

Connection Diagram
GEM2034E-FIG1



End shield Assembly		
Part Description	DE Side Part#	ODE Side Part#
End Shield	4004D5280PB1	4004D5280SG1
Bearing	235A2500AF01	235A2500AF01
Slinger/Inproseal	4002B5914AF1	4002B5914AG1

Fan & Fan Cover Assembly	
Part Description	Part#
Fan	4001A5914AM-G01
Fan Cover	4003C5785PA1

Conduit & Accessories Box Assembly	
Part Description	Part#
Conduit Box	4002B5718PA-G01

Mechanical Accessories	
Part Description	Part#
Brake	
Tachometer	

