



GE INDUSTRIAL MOTORS
a **WOLONG** company

Product Technical Information

February 14, 2022

Data shown is for the current revision model #. Ensure your nameplate model # matches.

Model Number:	5KS143SAA105D2
Catalog Number:	M486
Instruction Manual:	GEI-56128
Connection Diagram:	GEM2034E-FIG3
Outline Drawing:	4002B5814PAP5425

Accessory Connection Diagrams

Bearing Thermocouple:	None	Heater:	None
RTD:	None	Thermistor:	None
Thermostat:	None	Winding Thermocouple:	None
Bearing RTD:	None		

Table of Contents

Specification	01
Performance Characteristics	02
Outline Drawing	03
Connection Drawing(s)	04
Spare parts	05

Marks:

MODEL NUMBER: 5KS143SAA105D2
Outline Drawing: 4002B5814PAP5425
Connection Diagram: GEM2034E-FIG3
Instruction Book: GEI-56128
Design Code: 14BD0040A
Type: KS
Frame: 143T
Phases: 3
Poles: 2
Output Power: 1.5HP 1.1KW
RPM: 3495
Voltage: 230/460
Hertz: 60
Amps - FL: 4.2/2.1
Service Factor: 1.15
Alt Service Factor: --

Estimated Weight: 43 Lbs
Time Rating: CONT
Enclosure: TEFC
Encl Construction: 841
Ambient Max(°C): 40
Alt Ambient Max(°C): --
Insulation Class: H
NEMA Design: B
Nominal Efficiency: 84.0 %
Guaranteed Efficiency: 82.5 %
3/4 Load Efficiency: --
KVA Code: M
Max KVAR: 0.7
Power Factor: 79.0
Bearing - DE: 6205ZC3
Bearing - ODE: 6205ZC3

Enclosure is Totally Enclosed Fan-Cooled

Stamped Nameplate Notes:

DE BRG 25BC02JP30 ODE BRG 25BC02JP30
 EXCEPTION TO IEEE-STD-841-2009: DUAL VOLTAGE
 STAMP NP249A5564P051 AS BELOW:
 MODEL:5KS143SAA105D2 S/N: XXX
 CSA CERTIFIED CSA09.2216219 FOR EX NA IIC 200C GC
 CL 1 ZONE2 AEX NA IIC 200C;CL 1 DIV2 GRP ABCD 200C
 IN -40C <= AMB <= 40C, 1.0 SF ON SINE-WAVE PWR
 SURF TEMP 200C AT 1.15SF ON SINE-WAVE PWR
 OR 200C VT OR 200C CT OR 200C CHP PWM CONTROL
 ALTERNATE RATING FOR PWM CONTROL 1.0SF 40C AMB
 VT 0-60 HZ, CT 3-60 HZ, CHP 60-90 HZ.



Additional Information:

2P - T EXTN
STANDARD FLOOR MOUNT
C/BOX 30 CU IN-0.75 NPT
F1 CONDUIT BOX MOUNTING
PAINTED FRAME ID & SHAFT,
FAN COVER INSIDE & ODE E/S OUTSIDE
ROUTINE AND 5 POINT VIBRATION TESTS INCL IN C/BOX
GROUND SCREW ON FRAME
SHAFT RUNOUT LIMIT .001" TIR
OIL RESISTANT SLEEVING ON LEADS



Performance Characteristics

1st Winding 1st Connection

Design: 14BD0040A

Marks:

LOAD %	125.0	115.0	100.0	75.0	50.0	25.0	0.0
% EFF	84.06	84.32	84.67	83.83	80.98	71.27	0.00
% PF	83	81.57	82.69	71.62	59.46	39.52	12.53
AMPS	2.52	2.35	1.99	1.75	1.46	1.25	0.96

TORQ(FL)#FT	2.23	TORQ(LR)%FL	328.14	TORQ(BD)%FL	443.62
AMPS(LR)	18.18	PF AT START	0.57		

This motor is capable of two cold or one hot start with a maximum connected load inertia of 12 Lb-Ft Sq (0.51 Kg-meter Sq)at 100% voltage, where the load torque varies with the square of the speed. Acceleration time with maximum inertia and the above load type is 23 seconds. Safe stall time at 100% voltage is 50 seconds cold, 37 seconds hot. Rotor inertia is 0.04 Lb-Ft Sq (0 Kg-meter Sq).

Open Circuit A-C:	0.254	Short Circuit D-C:	0.005
Short Circuit A-C:	0.01	X/R Ratio:	1.805
Stator Slots:	24	Rotor Slots:	34

Speed Torque Current Curve (First Connection, First Speed)

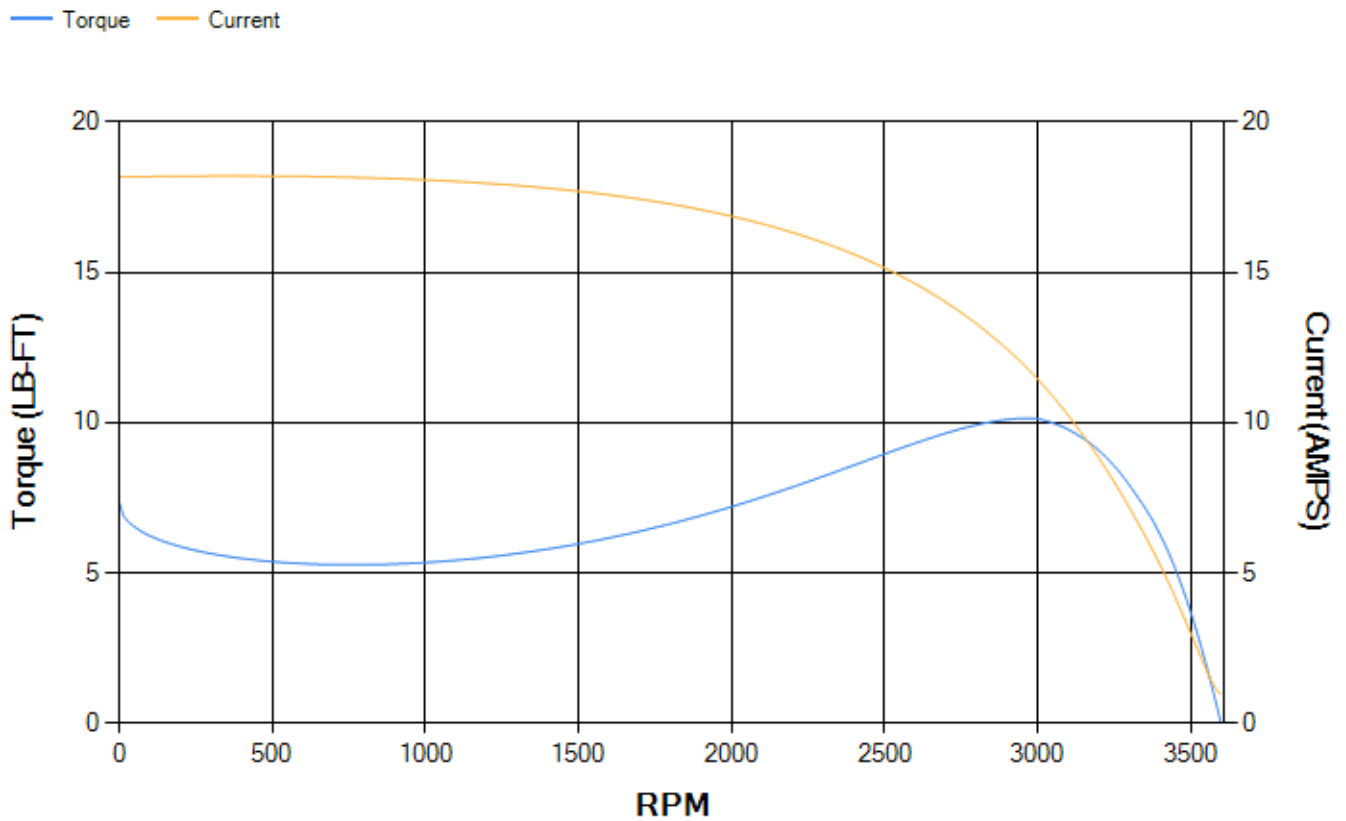

Marks:

NOTE 1: CONDUIT BOX MAY BE ASSEMBLED WITH ENTRANCE UP, DOWN OR TO EITHER SIDE.
 NOTE 2: FI ASSEMBLY AS SHOWN.
 NOTE 3: ALL DIMENSIONS ARE IN INCHES AND BRACKETED DIMENSIONS ARE IN METRIC [mm].

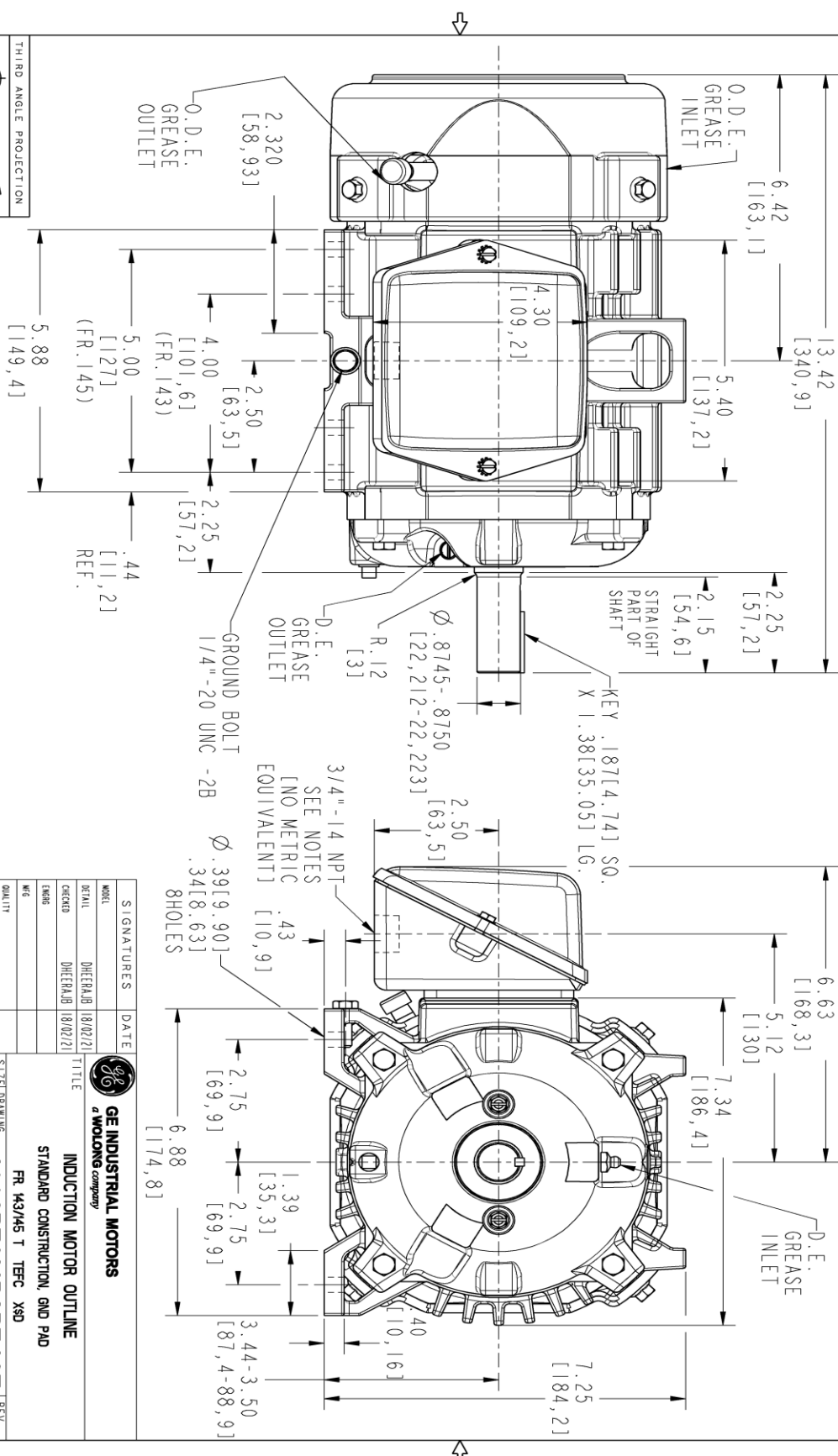

PROPRIETARY INFORMATION

4002B5814PAP5425

REV 0

REV.	DESCRIPTION	DATE	APPROVED

© COPYRIGHT 2018 Wolog Electric America LLC AND/OR ITS AFFILIATES. All rights reserved. This document and the information it contains is the property of Wolog Electric America LLC and/or its affiliates. It has been provided solely for transmission to the recipient for the specific purpose stated. Any other use, reproduction, or distribution of this document and/or its contents without the express written permission of Wolog Electric America LLC is strictly prohibited except as expressly authorized in writing by Wolog Electric America LLC.

SIGNATURES	DATE

GE INDUSTRIAL MOTORS
 a Wolog company

INDUCTION MOTOR OUTLINE
 STANDARD CONSTRUCTION, GND PAD

FR 143/45 T TFC XSD

4002B5814PAP5425

SCALE: 0.500 REF. No.: 4002B5814PAP201

SHEET 1 of 1

Marks:

Connection Diagram
GEM2034E-FIG3



End shield Assembly		
Part Description	DE Side Part#	ODE Side Part#
End Shield	4004D5280PB1	4004D5280SG1
Bearing	235A2500AF01	235A2500AF01
Slinger/Inproseal	149C4399G15	149C4399G15

Fan & Fan Cover Assembly	
Part Description	Part#
Fan	4001A5914AM-G01
Fan Cover	4003C5785PA1

Conduit & Accessories Box Assembly	
Part Description	Part#
Conduit Box	4002B5718PA-G01

Mechanical Accessories	
Part Description	Part#
Brake	
Tachometer	

