



GE INDUSTRIAL MOTORS
a **WOLONG** company

Product Technical Information

April 1, 2021

Data shown is for the current revision model #. Ensure your nameplate model # matches.

Model Number:	5KS143SAA302D1
Catalog Number:	M496
Instruction Manual:	GEI-56128
Connection Diagram:	GEM2034E-FIG3
Outline Drawing:	4002B5814PBP5311

Accessory Connection Diagrams

Bearing Thermocouple:	None	Heater:	None
RTD:	None	Thermistor:	None
Thermostat:	None	Winding Thermocouple:	None
Bearing RTD:	None		

Table of Contents

Specification	01
Performance Characteristics	02
Outline Drawing	03
Connection Drawing(s)	04
Spare parts	05

Marks:

MODEL NUMBER:	5KS143SAA302D1	Estimated Weight:	43 Lbs
Outline Drawing:	4002B5814PBP5311	Time Rating:	CONT
Connection Diagram:	GEM2034E-FIG3	Enclosure:	TEFC
Instruction Book:	GEI-56128	Encl Construction:	841
Design Code:	14BD3015AA	Ambient Max(°C):	40
Type:	KS	Alt Ambient Max(°C):	--
Frame:	143TC	Insulation Class:	H
Phases:	3	NEMA Design:	B
Poles:	6	Nominal Efficiency:	77.0 %
Output Power:	0.75HP 0.6KW	Guaranteed Efficiency:	75.5 %
RPM:	1140	3/4 Load Efficiency:	--
Voltage:	230/460	KVA Code:	P
Hertz:	60	Max KVAR:	0.8
Amps - FL:	3.2/1.6	Power Factor:	58.0
Service Factor:	1.15	Bearing - DE:	6206ZC3
Alt Service Factor:	--	Bearing - ODE:	6205ZC3

Enclosure is Totally Enclosed Fan-Cooled

Stamped Nameplate Notes:

DE BRG 30BC02JP30 ODE BRG 25BC02JP30
 EXCEPTION TO IEEE-STD-841-2009: DUAL VOLTAGE
 STAMP NP249A5564P051 AS BELOW:
 MODEL:5KS143SAA302D1 S/N: XXX
 CSA CERTIFIED CSA09.2216219 FOR EX NA IIC 200C GC
 CL 1 ZONE2 AEX NA IIC 200C;CL 1 DIV2 GRP ABCD 200C
 IN -25C <= AMB <= 40C, 1.0 SF ON SINE-WAVE PWR
 SURF TEMP 200C AT 1.15SF ON SINE-WAVE PWR
 OR 200C VT OR 200C CT OR 200C CHP PWM CONTROL
 ALTERNATE RATING FOR PWM CONTROL 1.0SF 40C AMB
 VT 0-60 HZ, CT 3-60 HZ, CHP 60-90 HZ.



Additional Information:

6P - T EXTN
STANDARD FLOOR MOUNT
C/BOX 30 CU IN-0.75 NPT
F1 CONDUIT BOX MOUNTING
"C" FACE AT DE ENDSHIELD
PAINTED FRAME ID & SHAFT,
FAN COVER INSIDE & ODE E/S OUTSIDE
ROUTINE AND 5 POINT VIBRATION TESTS INCL IN C/BOX
INPRO SEAL DE ONLY
GROUND SCREW ON FRAME
SHAFT RUNOUT LIMIT .001" TIR
OIL RESISTANT SLEEVING ON LEADS



Performance Characteristics

1st Winding 1st Connection

Design: 14BD3015AA

Marks:

LOAD %	125.0	115.0	100.0	75.0	50.0	25.0	0.0
% EFF	78.36	78.64	78.93	77.6	73.49	61.15	0.00
% PF	65.05	62.38	59.67	48.44	36.87	23.37	8.55
AMPS	1.72	1.65	1.49	1.4	1.3	1.23	1.13

TORQ(FL)#FT	3.42	TORQ(LR)%FL	333.66	TORQ(BD)%FL	384.69
AMPS(LR)	7.7	PF AT START	0.65		

This motor is capable of two cold or one hot start with a maximum connected load inertia of 136 Lb-Ft Sq (5.73 Kg-meter Sq)at 100% voltage, where the load torque varies with the square of the speed. Acceleration time with maximum inertia and the above load type is 50 seconds. Safe stall time at 100% voltage is 110 seconds cold, 80 seconds hot. Rotor inertia is 0.07 Lb-Ft Sq (0 Kg-meter Sq).

Open Circuit A-C:	0.064	Short Circuit D-C:	0.005
Short Circuit A-C:	0.006	X/R Ratio:	1.834
Stator Slots:	36	Rotor Slots:	48

Speed Torque Current Curve (First Connection, First Speed)

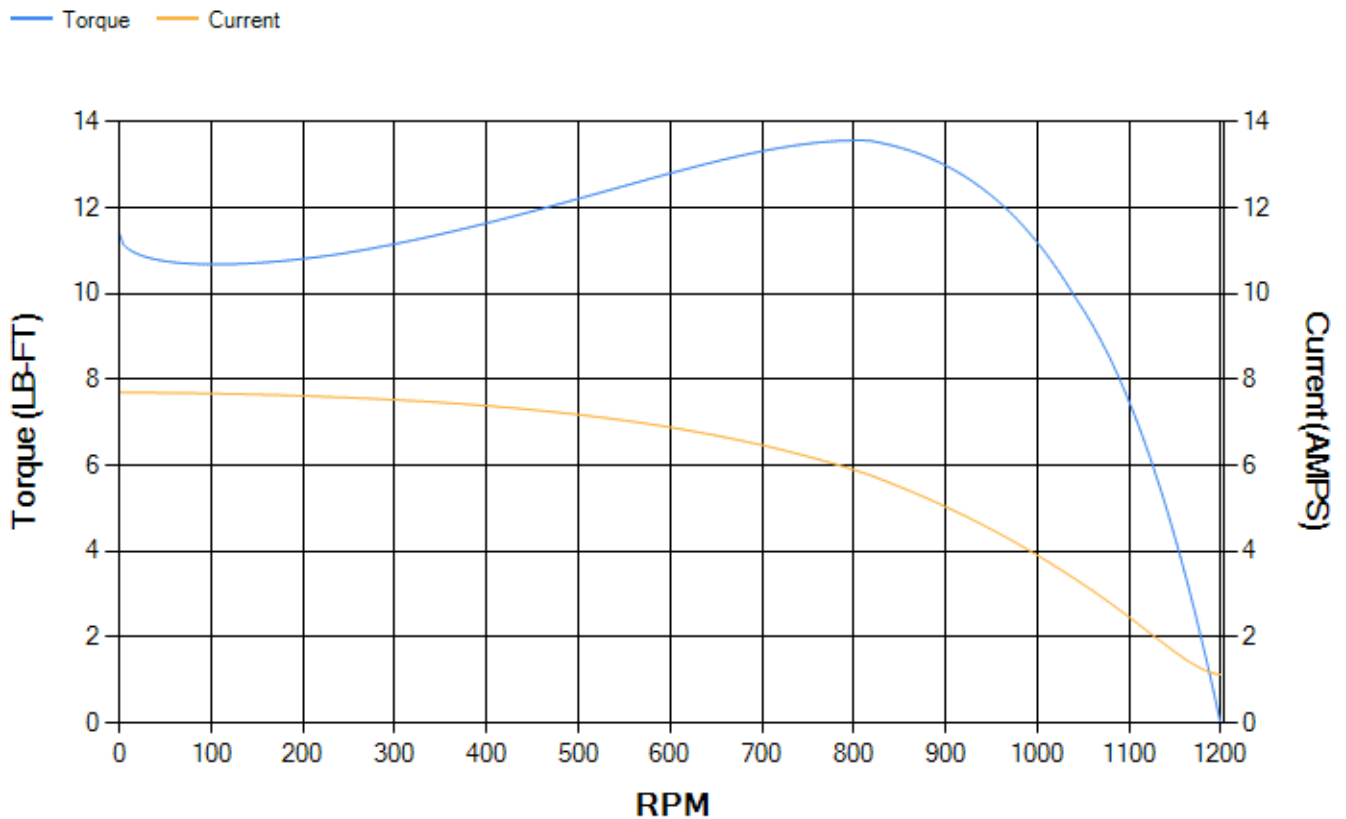

Marks:

Connection Diagram
GEM2034E-FIG3

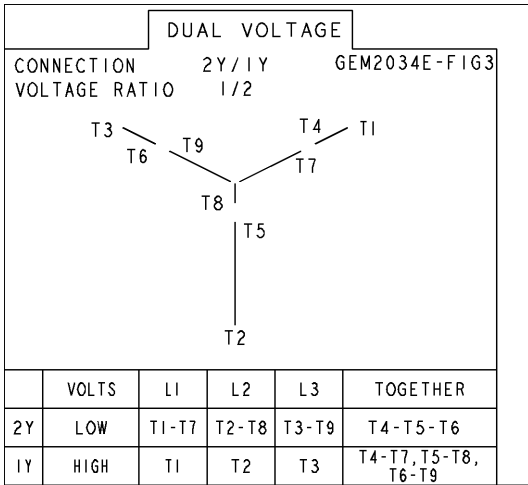

End shield Assembly		
Part Description	DE Side Part#	ODE Side Part#
End Shield	4004D5289PB1	4004D5280SG1
Bearing	235A2502AM01	235A2500AF01
Slinger/Inproseal	4002B5914AM1	149C4399G15

Fan & Fan Cover Assembly	
Part Description	Part#
Fan	4001A5914AM-G01
Fan Cover	4003C5785PA1

Conduit & Accessories Box Assembly	
Part Description	Part#
Conduit Box	4002B5718PA-G01

Mechanical Accessories	
Part Description	Part#
Brake	
Tachometer	

