



GE INDUSTRIAL MOTORS
a **WOLONG** company

Product Technical Information

June 23, 2020

Data shown is for the current revision model #. Ensure your nameplate model # matches.

Model Number:	5KS143XAA200D3
Catalog Number:	M520
Instruction Manual:	GEI-56128
Connection Diagram:	GEM2034E-FIG1
Outline Drawing:	4002B5814PBP5311

Accessory Connection Diagrams

Bearing Thermocouple:	None	Heater:	None
RTD:	None	Thermistor:	None
Thermostat:	None	Winding Thermocouple:	None
Bearing RTD:	None		

Table of Contents

Specification	01
Performance Characteristics	02
Outline Drawing	03
Connection Drawing(s)	04
Spare parts	05

Marks:

MODEL NUMBER:	5KS143XAA200D3	Estimated Weight:	43 Lbs
Outline Drawing:	4002B5814PBP5311	Time Rating:	CONT
Connection Diagram:	GEM2034E-FIG1	Enclosure:	TEFC
Instruction Book:	GEI-56128	Encl Construction:	841
Design Code:	14BD1092A	Ambient Max(°C):	40
Type:	KS	Alt Ambient Max(°C):	--
Frame:	143TC	Insulation Class:	H
Phases:	3	NEMA Design:	B
Poles:	4	Nominal Efficiency:	85.5 %
Output Power:	1HP 0.7KW	Guaranteed Efficiency:	84.0 %
RPM:	1755	3/4 Load Efficiency:	85.0 %
Voltage:	460	KVA Code:	N
Hertz:	60	Max KVAR:	0.7
Amps - FL:	1.6	Power Factor:	70.5
Service Factor:	1.15	Bearing - DE:	6206ZC3
Alt Service Factor:	--	Bearing - ODE:	6205ZC3

Enclosure is Totally Enclosed Fan-Cooled

Stamped Nameplate Notes:

IEEE-STD-841-2009
 DE BRG 30BC02JP30 ODE BRG 25BC02JP30
 STAMP NP249A5564P051 AS BELOW:
 MODEL:5KS143XAA200D3 S/N: XXX
 CSA CERTIFIED CSA09.2216219 FOR EX NA IIC 200 C GC
 CL1 ZONE2 AEXNAIIC 200C FOR CL1DIV2 GRP ABCD 200C
 IN -25C <= AMB <= 40C, 1.0SF ON SINE-WAVE PWR
 SURF TEMP 200 C AT 1.15 SF ON SINE-WAVE PWR
 OR 200 C VT OR 200 C CT OR 200 C CHP PWM CONTROL
 ALTERNATE RATING FOR PWM CONTROL 1.0SF 40 C AMB
 VT 0-60 HZ, CT 3-60 HZ, CHP 60-90 HZ.

Additional Information:

4P - T EXTN
 STANDARD FLOOR MOUNT
 C/BOX 30 CU IN-0.75 NPT
 F1 CONDUIT BOX MOUNTING
 "C" FACE AT DE ENDSHIELD
 PAINTED FRAME ID & SHAFT,
 FAN COVER INSIDE & ODE E/S OUTSIDE
 ROUTINE AND 5 POINT VIBRATION TESTS INCL IN C/BOX
 INPRO SEAL BOTH ENDS
 GROUND SCREW ON FRAME
 SHAFT RUNOUT LIMIT .001" TIR
 COPPER WASHER UNDER HEADS OF BEARING CAP BOLTS
 APPLY TITE-SEAL (A50CD427A) ON BEARING CAP SCREWS, RABBETS,
 AND PLUG THREADS



OIL RESISTANT SLEEVING ON LEADS



Performance Characteristics

1st Winding 1st Connection

Design: 14BD1092A

Marks:

LOAD %	125.0	115.0	100.0	75.0	50.0	25.0	0.0
% EFF	85.48	85.65	85.9	84.94	82.06	72.51	0.00
% PF	76.81	74.65	72.4	61.65	48.5	30.38	8.26
AMPS	1.78	1.68	1.5	1.34	1.18	1.06	0.94

TORQ(FL)#FT 3 TORQ(LR)%FL 471.82 TORQ(BD)%FL 541.11
 AMPS(LR) 12.69 PF AT START 0.68

This motor is capable of two cold or one hot start with a maximum connected load inertia of 84 Lb-Ft Sq (3.54 Kg-meter Sq)at 100% voltage, where the load torque varies with the square of the speed. Acceleration time with maximum inertia and the above load type is 37 seconds. Safe stall time at 100% voltage is 82 seconds cold, 66 seconds hot. Rotor inertia is 0.08 Lb-Ft Sq (0 Kg-meter Sq).

Open Circuit A-C: 0.13 Short Circuit D-C: 0.005
 Short Circuit A-C: 0.006 X/R Ratio: 1.758
 Stator Slots: 36 Rotor Slots: 48

Speed Torque Current Curve (First Connection, First Speed)

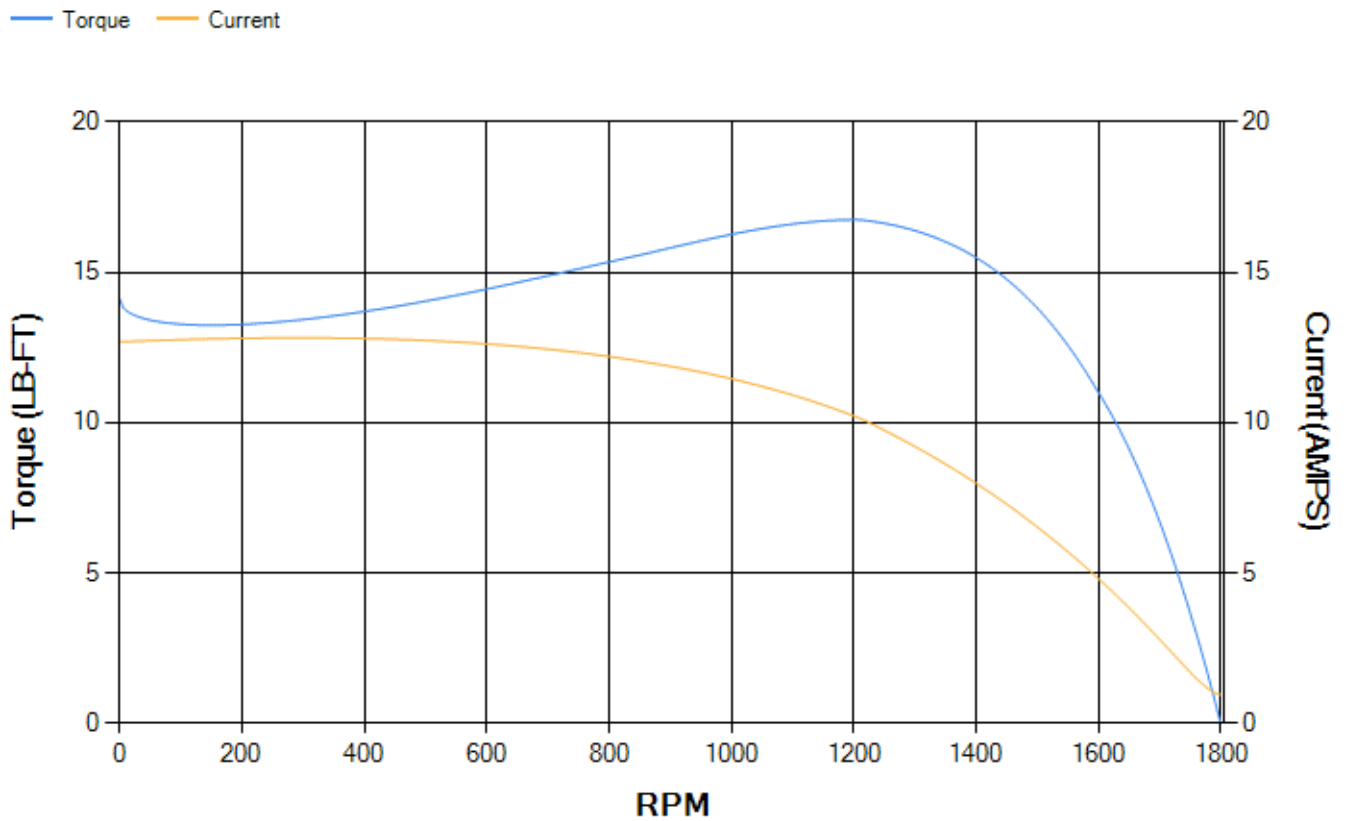

Marks:

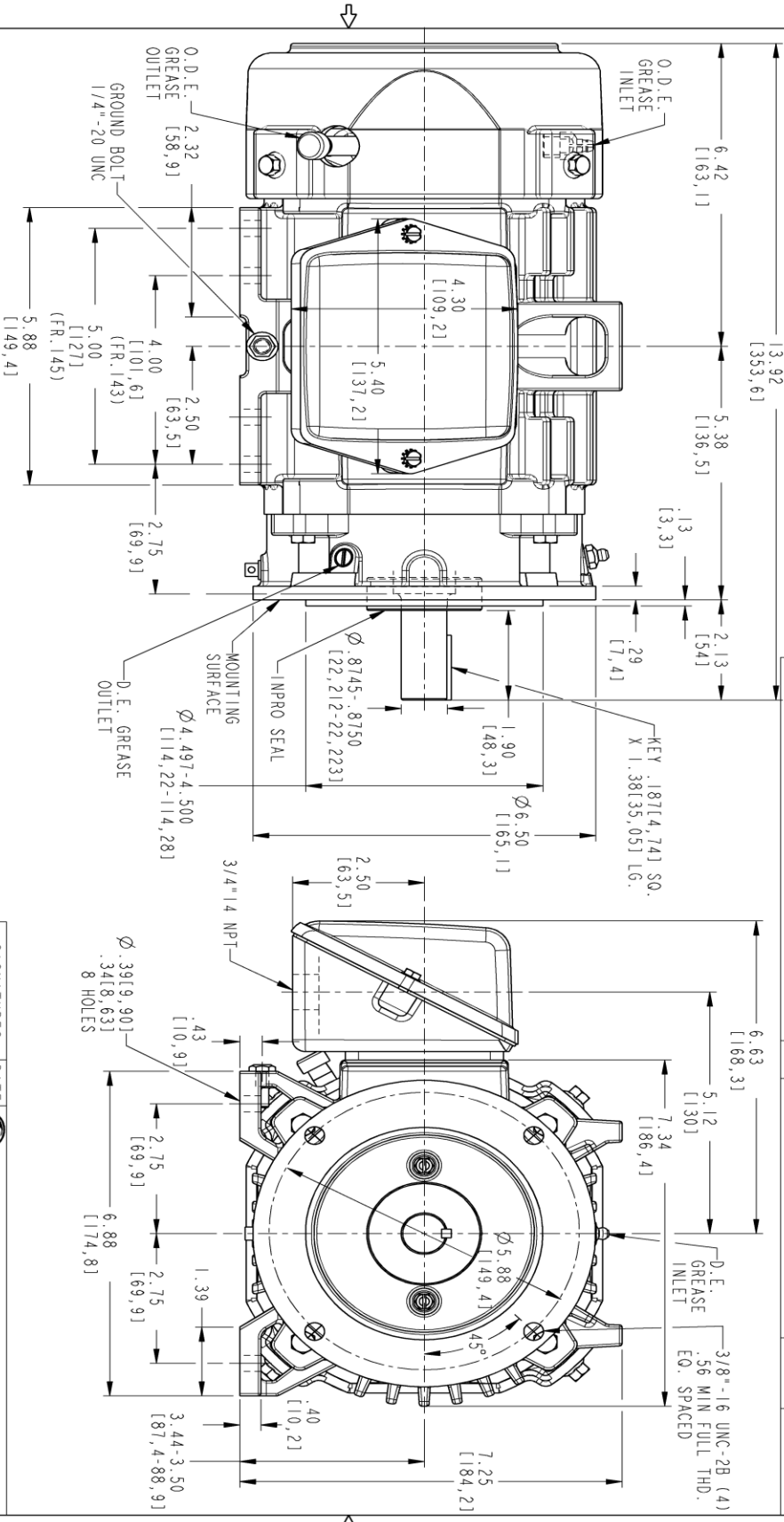

PROPRIETARY INFORMATION
 © COPYRIGHT 2018 Wolong Electric America LLC AND/OR ITS AFFILIATES.
 All rights reserved. This document and the information it contains is the property of
 the Wolong Electric America LLC and/or its affiliates. It has been provided solely for
 your use and is not to be distributed, copied, or used for any other purpose without
 the express written permission of Wolong Electric America LLC. Any other use is
 strictly prohibited except as expressly authorized in writing by
 the Wolong Electric America LLC.

REV.	DESCRIPTION	DATE	APPROVED
1	ISAC# 18-0869	10/23/18	PRASHANTH

SIZE DRAWING NO.	B	REV	001	SHEET	1
4002B5814PBP5311 001					
REVISIONS					



NOTE 1: CONDUIT BOX MAY BE ASSEMBLED WITH ENTRANCE UP, DOWN OR TO EITHER SIDE.
 NOTE 2: F1 ASSEMBLY AS SHOWN. F2 ASSEMBLY CONDUIT BOX ON OPPOSITE SIDE FROM SHOWN LOCATION.
 NOTE 3: MOUNTING SURFACES WILL BE SQUARE AND CONCENTRIC WITH SHAFT WITHIN .004 T.I.R.
 NOTE 4: SHAFT RUNOUT WILL NOT EXCEED .001 T.I.R.
 NOTE 5: ALL DIMENSIONS ARE IN INCHES, BRACKETED DIMENSIONS ARE IN METRIC (MILLIMETERS).

SIGNATURES	DATE	GE INDUSTRIAL MOTORS a Wolong company
MODEL	TEJASNI 06/08/15	INDUCTION MOTOR OUTLINE IEEE-841 SPEC, "C" FACE AT DE 14.50" RABBERT) FR. 143/METC TERC
DETAIL	TEJASNI 06/08/15	
DESIGN	ADI 06/08/15	
ENGR	VENKAT 06/08/15	
WEC		
QUALITY	TEJASNI 06/08/15	
ISSUED	B	
SOLID MODEL:	4002B5814PBP5311	
SCALE:	0.500	REF. No.: 4002B5814PBP5301
		SHEET 1 of 1

Marks:

Connection Diagram
GEM2034E-FIG1



End shield Assembly		
Part Description	DE Side Part#	ODE Side Part#
End Shield	4004D5289PB1	4004D5280SG1
Bearing	235A2502AM01	235A2500AF01
Slinger/Inproseal	4002B5914AM1	4002B5914AG1

Fan & Fan Cover Assembly	
Part Description	Part#
Fan	4001A5914AM-G01
Fan Cover	4003C5785PA1

Conduit & Accessories Box Assembly	
Part Description	Part#
Conduit Box	4002B5718PA-G01

Mechanical Accessories	
Part Description	Part#
Brake	
Tachometer	

