



GE INDUSTRIAL MOTORS
a **WOLONG** company

Product Technical Information

June 24, 2020

Data shown is for the current revision model #. Ensure your nameplate model # matches.

Model Number:	5KS215XAA220BW8
Catalog Number:	M6623
Instruction Manual:	GEI-56128
Connection Diagram:	GEM2034E-FIG7
Outline Drawing:	4002B5821PAP5711

Accessory Connection Diagrams

Bearing Thermocouple:	None	Heater:	None
RTD:	None	Thermistor:	None
Thermostat:	None	Winding Thermocouple:	None
Bearing RTD:	None		

Table of Contents

Specification	01
Performance Characteristics	02
Outline Drawing	03
Connection Drawing(s)	04
Spare parts	05

Marks:

MODEL NUMBER:	5KS215XAA220BW8	Estimated Weight:	220 Lbs
Outline Drawing:	4002B5821PAP5711	Time Rating:	CONT
Connection Diagram:	GEM2034E-FIG7	Enclosure:	TEFC
Instruction Book:	GEI-56128	Encl Construction:	661
Design Code:	21BD1267A	Ambient Max(°C):	40
Type:	KS	Alt Ambient Max(°C):	--
Frame:	215T	Insulation Class:	H
Phases:	3	NEMA Design:	B
Poles:	4	Nominal Efficiency:	91.7 %
Output Power:	10HP 7.4KW	Guaranteed Efficiency:	91.0 %
RPM:	1770	3/4 Load Efficiency:	92.5 %
Voltage:	460	KVA Code:	H
Hertz:	60	Max KVAR:	3.1
Amps - FL:	12.2	Power Factor:	83.5
Service Factor:	1.15	Bearing - DE:	NU208ECJ/C3
Alt Service Factor:	--	Bearing - ODE:	6208ZC3

Enclosure is Totally Enclosed Fan-Cooled

Stamped Nameplate Notes:

API-STD-661
 DE BRG 40RU02X3 ODE BRG 40BC02JP30
 IP 56
 ROLLER BEARING - FOR BELTED LOAD ONLY
 STAMP NP249A5564P051 AS BELOW:
 MODEL:5KS215XAA220BW8 S/N: XXX
 CSA CERTIFIED CSA09.2216219 FOR EX NA IIC 200 C GC
 CL1ZONE2 AEXNAIIC 200 C; CL1DIV2 GRP ABCD 200 C
 IN -25C <= AMB <= 40C, 1.0 SF ON SINE-WAVE PWR
 SURF TEMP 200 C AT 1.15 SF ON SINE-WAVE PWR
 OR 200 C VT OR 200 C CT OR 200 C CHP PWM CONTROL
 ALTERNATE RATING FOR PWM CONTROL 1.0 SF 40 C AMB
 VT 0-60 HZ, CT 3-60 HZ, CHP 60-90 HZ.



Additional Information:

4P - T EXTN
STANDARD WALL MOUNT SHAFT UP
C/BOX 55 CU IN-1.00 NPT
VERTICAL MOUNT SHAFT UP
PAINTED FRAME ID & SHAFT,
FAN COVER INSIDE & ODE E/S OUTSIDE
ROUTINE AND 5 POINT VIBRATION TESTS INCL IN C/BOX
INPRO SEAL BOTH ENDS
GROUND SCREW ON FRAME
SHAFT RUNOUT LIMIT .001" TIR
COPPER WASHER UNDER HEADS OF BEARING CAP BOLTS
APPLY TITE-SEAL (A50CD427A) ON BEARING CAP SCREWS, RABBETS,
AND PLUG THREADS
OIL RESISTANT SLEEVING ON LEADS
B5F4C4 HIGH FATIGUE STEEL AISI 4142 SHAFT MATERIAL



Performance Characteristics

1st Winding 1st Connection

Design: 21BD1267A

Marks:

LOAD %	125.0	115.0	100.0	75.0	50.0	25.0	0.0
% EFF	90.62	91.16	92.02	92.49	92.22	88.9	0.00
% PF	84.19	84.08	83.37	80.09	71.64	50.56	5.78
AMPS	15.33	14.04	12.2	9.48	7.08	5.21	4.28

TORQ(FL)#FT	29.7	TORQ(LR)%FL	196.58	TORQ(BD)%FL	280.86
AMPS(LR)	80.95	PF AT START	0.4		

This motor is capable of two cold or one hot start with a maximum connected load inertia of 376 Lb-Ft Sq (15.83 Kg-meter Sq) at 100% voltage, where the load torque varies with the square of the speed. Acceleration time with maximum inertia and the above load type is 49 seconds. Safe stall time at 100% voltage is 109 seconds cold, 74 seconds hot. Rotor inertia is 1.12 Lb-Ft Sq (0.05 Kg-meter Sq).

Open Circuit A-C:	0.421	Short Circuit D-C:	0.014
Short Circuit A-C:	0.02	X/R Ratio:	5.093
Stator Slots:	36	Rotor Slots:	28

Speed Torque Current Curve (First Connection, First Speed)

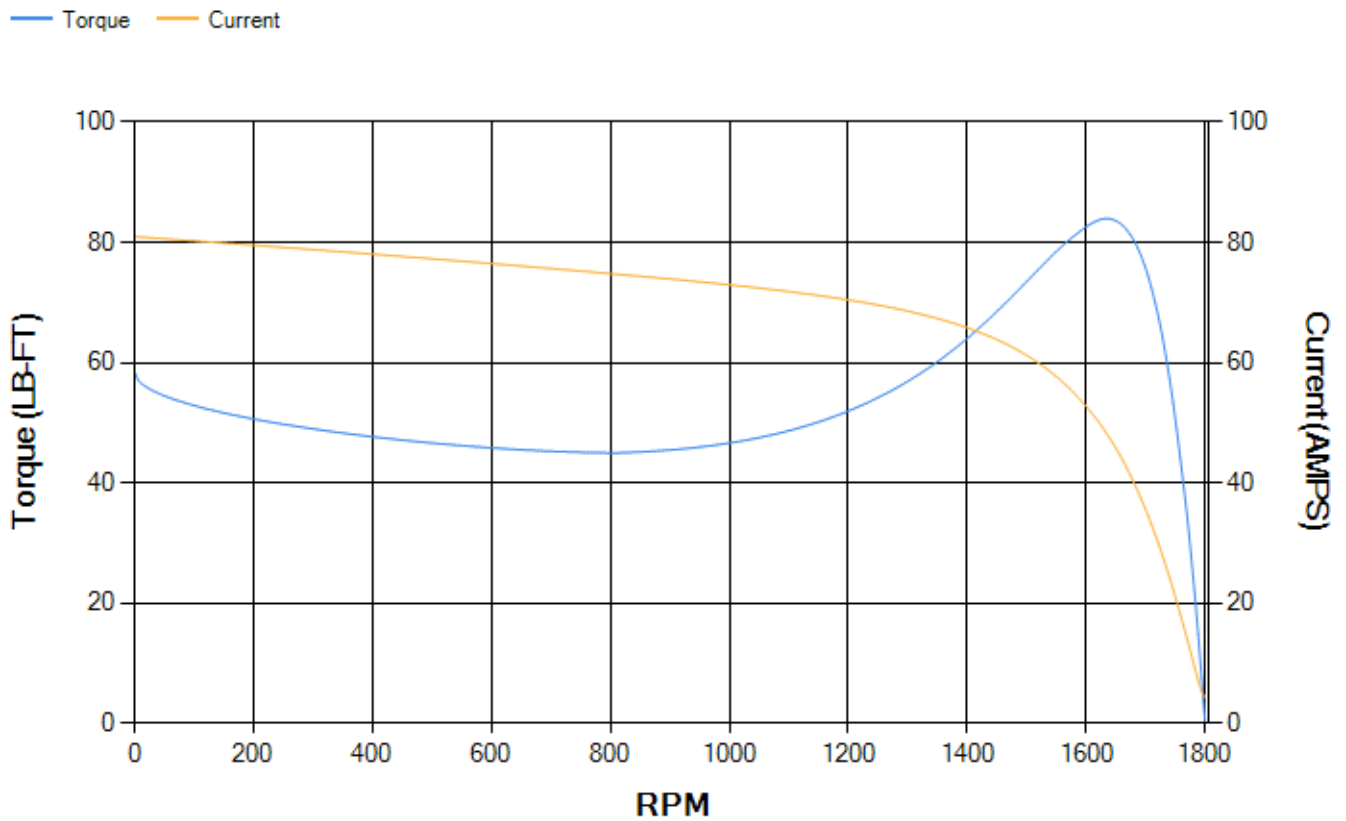

Marks:

- NOTE 1: CONDUIT BOX MAY BE ASSEMBLED WITH ENTRANCE UP, DOWN OR TO EITHER SIDE.
 NOTE 2: F1 ASSEMBLY AS SHOWN. F2 ASSEMBLY CONDUIT BOX ON OPPOSITE SIDE FROM SHOWN LOCATION.
 NOTE 3: SHAFT RUNOUT WILL NOT EXCEED .001 T.I.R.
 NOTE 4: ALL DIMENSIONS ARE IN INCHES, BRACKETED DIMENSIONS ARE IN METRIC (MILLIMETERS).

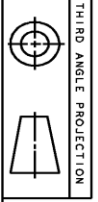
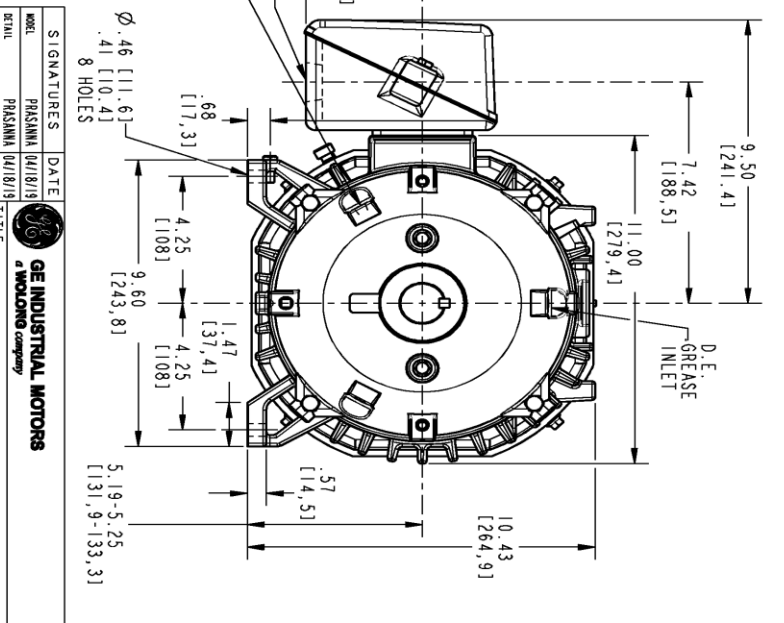
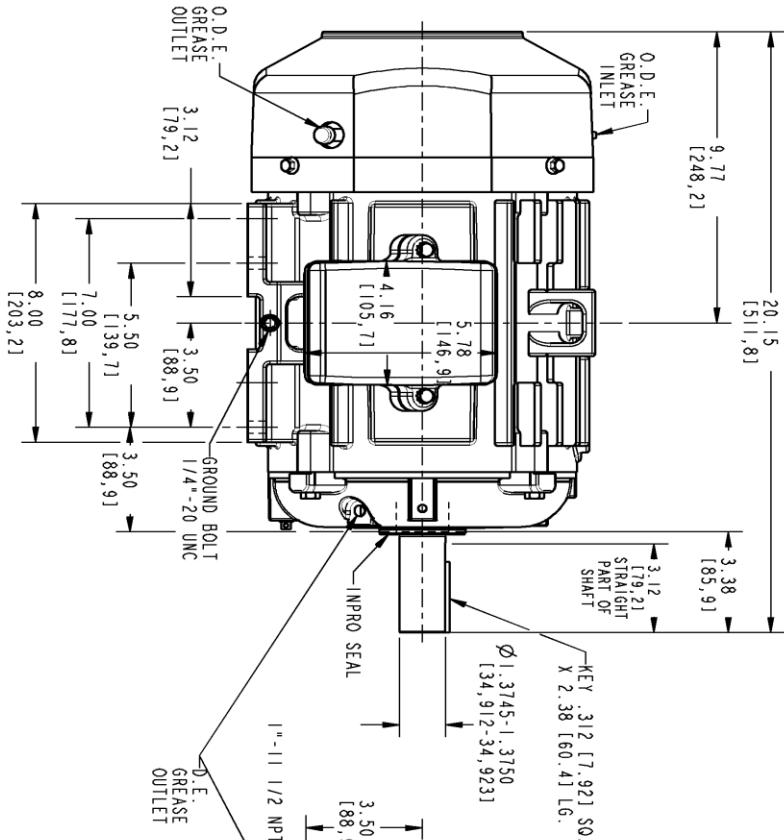

PROPERTY INFORMATION	REV	SHEET
4002B5821PAP5711 000	1	1
REVISIONS	DATE	APPROVED
REV.		
DESCRIPTION		

SIGNATURES		DATE
MODEL	PRASANK	04/18/19
RETAIL	PRASANK	04/18/19
CRACK	PRASANK	04/18/19
CHGR	PRASANK	04/18/19
W/E	PRASANK	04/18/19
QUALITY	PRASANK	04/18/19
ISSUED	PRASANK	04/18/19
SHEET	1	1

GE INDUSTRIAL MOTORS
 a WOLSKEL company

TITLE
 INDUCTION MOTOR OUTLINE

STANDARD CONSTRUCTION FOR IEEE-841 SPEC

FAC: FR3/2S 1 TFC SHAFT UP WITH MIN INPRO

4002B5821PAP5711 000

SCALE: 0.300 REF. NO.: 4002B5821PAP5716

Marks:

Connection Diagram
GEM2034E-FIG7



End shield Assembly		
Part Description	DE Side Part#	ODE Side Part#
End Shield	4004D5282RB1	4004D5282SJ1
Bearing	235A2527AB01	235A2503AE01
Slinger/Inproseal	4002B5914GK3	4002B5914AG3

Fan & Fan Cover Assembly	
Part Description	Part#
Fan	159C6700G01
Fan Cover	4003C5787PA1

Conduit & Accessories Box Assembly	
Part Description	Part#
Conduit Box	4002B5721PA-G01

Mechanical Accessories	
Part Description	Part#
Brake	
Tachometer	

