



GE INDUSTRIAL MOTORS
a **WOLONG** company

Product Technical Information

February 17, 2023

Data shown is for the current revision model #. Ensure your nameplate model # matches.

Model Number:	5KGS284SAA208
Catalog Number:	M8801
Instruction Manual:	GEI-56128
Connection Diagram:	GEM2034E-FIG7
Outline Drawing:	4002B5828PAP5201

Accessory Connection Diagrams

Bearing Thermocouple:	None	Heater:	None
RTD:	None	Thermistor:	None
Thermostat:	None	Winding Thermocouple:	None
Bearing RTD:	None		

Table of Contents

Specification	01
Performance Characteristics	02
Outline Drawing	03
Connection Drawing(s)	04
Spare parts	05

Marks:

MODEL NUMBER:	5KGS284SAA208	Estimated Weight:	460 Lbs
Outline Drawing:	4002B5828PAP5201	Time Rating:	CONT
Connection Diagram:	GEM2034E-FIG7	Enclosure:	TEFC
Instruction Book:	GEI-56128	Encl Construction:	X\$D
Design Code:	28BD1179A	Ambient Max(°C):	40
Type:	KGS	Alt Ambient Max(°C):	--
Frame:	284T	Insulation Class:	H
Phases:	3	NEMA Design:	A
Poles:	4	Nominal Efficiency:	93.6 %
Output Power:	25HP 18.5KW	Guaranteed Efficiency:	93.0 %
RPM:	1775	3/4 Load Efficiency:	--
Voltage:	460	KVA Code:	H
Hertz:	60	Max KVAR:	5.8
Amps - FL:	28.4	Power Factor:	88.0
Service Factor:	1.15	Bearing - DE:	6310ZC3
Alt Service Factor:	--	Bearing - ODE:	6310ZC3

Enclosure is Totally Enclosed Fan-Cooled

Stamped Nameplate Notes:

INVERTER DUTY PER NEMA MG1 PART 31
 ALTERNATE RATING FOR PWM CONTROL:1.0SF 40C AMBIENT
 VAR TORQUE RANGE 0-60 HZ



Additional Information:

4P - T EXTN
STANDARD FLOOR MOUNT
C/BOX 137 CU IN-1.50 NPT
F1 CONDUIT BOX MOUNTING
OIL RESISTANT SLEEVING ON LEADS
NEMA C TORQUE LEVELS



Performance Characteristics

1st Winding 1st Connection

Design: 28BD1179A

Marks:

LOAD %	125.0	115.0	100.0	75.0	50.0	25.0	0.0
% EFF	92.32	92.79	93.61	94.16	94.29	92.35	0.00
% PF	88.56	88.55	88.14	85.89	79.35	59.62	4.8
AMPS	35.77	32.75	28.34	21.7	15.64	10.62	8.07

TORQ(FL)#FT	73.89	TORQ(LR)%FL	271.11	TORQ(BD)%FL	283.54
AMPS(LR)	206.86	PF AT START	0.49		

This motor is capable of two cold or one hot start with a maximum connected load inertia of 1032 Lb-Ft Sq (43.45 Kg-meter Sq)at 100% voltage, where the load torque varies with the square of the speed. Acceleration time with maximum inertia and the above load type is 41 seconds. Safe stall time at 100% voltage is 78 seconds cold, 53 seconds hot. Rotor inertia is 5.39 Lb-Ft Sq (0.23 Kg-meter Sq).

Open Circuit A-C:	0.72	Short Circuit D-C:	0.011
Short Circuit A-C:	0.021	X/R Ratio:	4.305
Stator Slots:	48	Rotor Slots:	40

Speed Torque Current Curve (First Connection, First Speed)

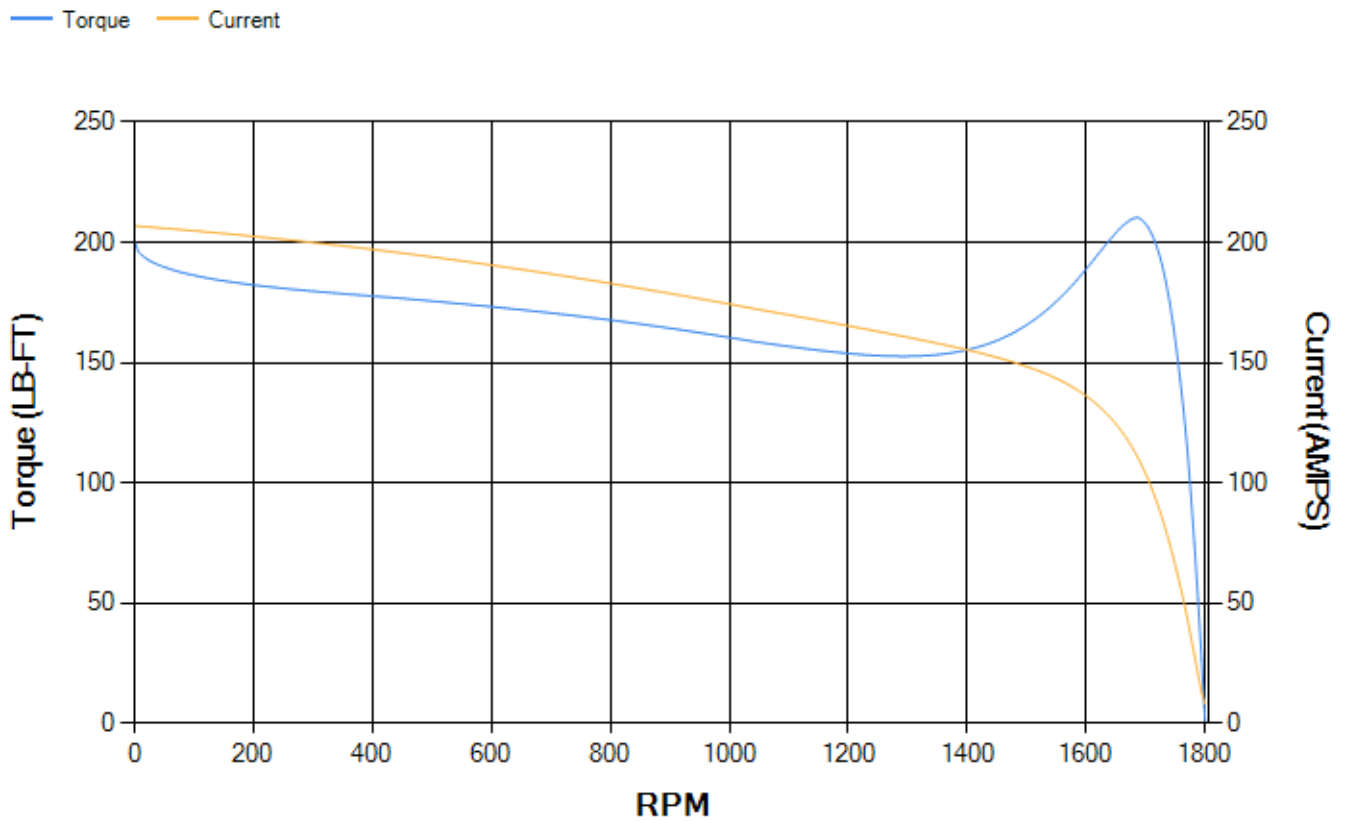

Marks:

NOTE 1: CONDUIT BOX MAY BE ASSEMBLED WITH ENTRANCE UP, DOWN OR TO EITHER SIDE.
 NOTE 2: F1 ASSEMBLY AS SHOWN. F2 ASSEMBLY CONDUIT BOX ON OPPOSITE SIDE FROM SHOWN LOCATION.

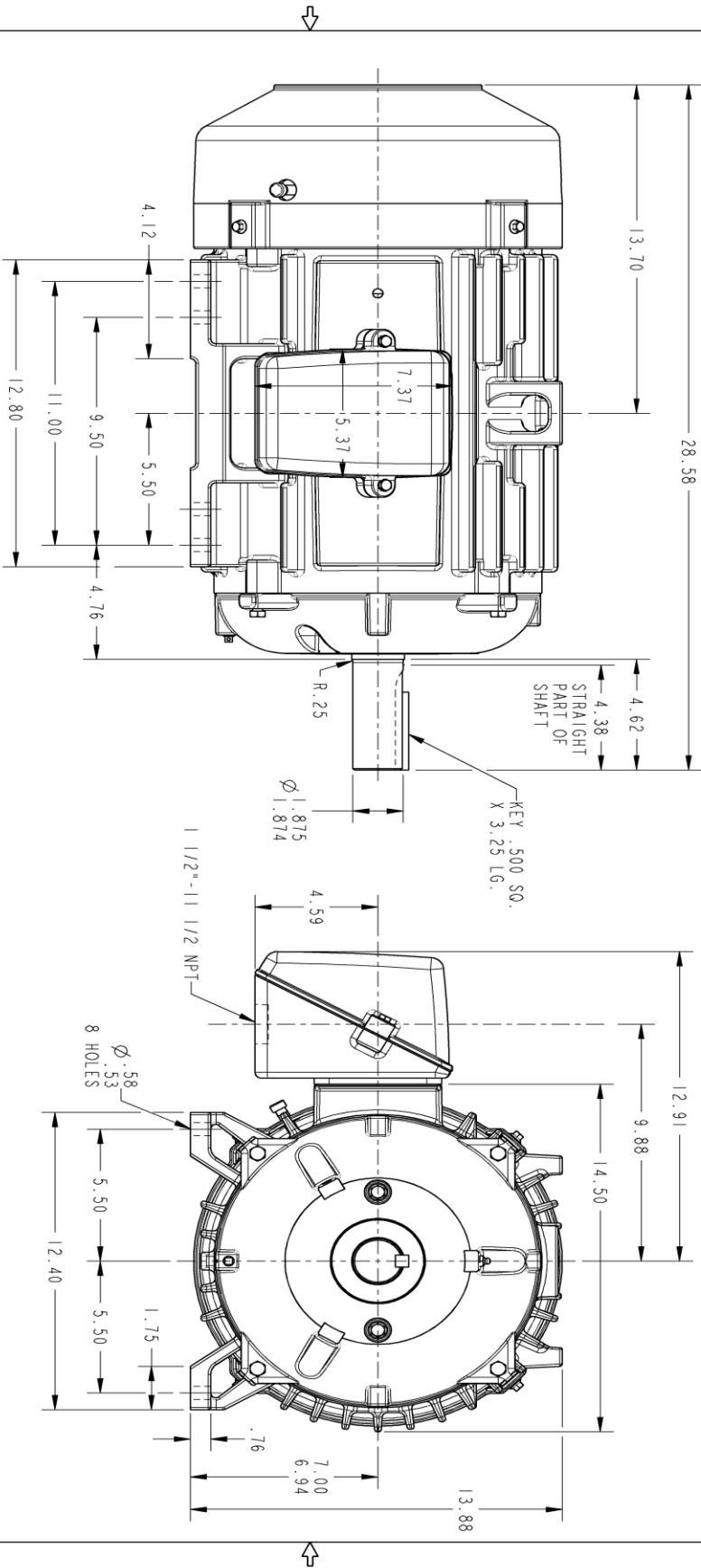

PROPRIETARY INFORMATION
 © COPYRIGHT 2018 Wolog Electric America LLC AND/OR ITS AFFILIATES.
 All rights reserved. This document and the information it contains is the property of the Wolog Electric America LLC and/or its affiliates. It has been provided solely for transmission to the recipient for their use only. Any other use, reproduction, or distribution of this information without the express written consent of Wolog Electric America LLC is strictly prohibited except as expressly authorized in writing by the Wolog Electric America LLC.

REVISIONS		DATE	APPROVED
REV.	DESCRIPTION		
1	ISAAC# 18-0869	01/31/19	PRASHANTH

SIZE	DRAWING NO.	REV	SHEET
B	4002B5828PAP5201	001	1

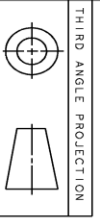

THIRD ANGLE PROJECTION

SIGNATURES		DATE	<p>GE INDUSTRIAL MOTORS a Wolog company</p> <p>INDUCTION MOTOR OUTLINE STANDARD CONSTRUCTION</p> <p>FME: FR280T TFC XSD ULTRA</p> <p>4002B5828PAP5201</p>
MODEL	GARY WARRNER	12/13/01	
DETAIL	GARY WARRNER	02/28/02	
ENGR			
QC			
QUALITY			SCALE: 0.250 REF. No.: 4002B5828PAP201
ISSUED	GARY WARRNER	04/05/02	
SHEET DRAWING			REV
4002B5828PAP5201			001

Marks:

Connection Diagram
GEM2034E-FIG7



End shield Assembly		
Part Description	DE Side Part#	ODE Side Part#
End Shield	4004D5284PB1	4004D5284SE1
Bearing	235A2608AA01	235A2608AA01
Slinger/Inproseal	149C4399G03	149C4399G03

Fan & Fan Cover Assembly	
Part Description	Part#
Fan	159C6700G02
Fan Cover	4003C5789PA1

Conduit & Accessories Box Assembly	
Part Description	Part#
Conduit Box	4002B5728PA-G01

Mechanical Accessories	
Part Description	Part#
Brake	
Tachometer	

