



GE INDUSTRIAL MOTORS
a **WOLONG** company

Product Technical Information

September 4, 2021

Data shown is for the current revision model #. Ensure your nameplate model # matches.

Model Number:	5KS449XAA123D9
Catalog Number:	M8943
Instruction Manual:	GEI-56128
Connection Diagram:	GEM2034E-FIG20
Outline Drawing:	239C6800ZC

Accessory Connection Diagrams

Bearing Thermocouple:	None	Heater:	None
RTD:	None	Thermistor:	None
Thermostat:	None	Winding Thermocouple:	None
Bearing RTD:	None		

Table of Contents

Specification	01
Performance Characteristics	02
Outline Drawing	03
Connection Drawing(s)	04
Spare parts	05

Marks:

MODEL NUMBER:	5KS449XAA123D9	Estimated Weight:	2770 Lbs
Outline Drawing:	239C6800ZC	Time Rating:	CONT
Connection Diagram:	GEM2034E-FIG20	Enclosure:	TEFC
Instruction Book:	GEI-56128	Encl Construction:	841
Design Code:	49BD0193A	Ambient Max(°C):	40
Type:	KS	Alt Ambient Max(°C):	--
Frame:	449TS	Insulation Class:	H
Phases:	3	NEMA Design:	B
Poles:	2	Nominal Efficiency:	95.8 %
Output Power:	250HP 185KW	Guaranteed Efficiency:	95.4 %
RPM:	3580	3/4 Load Efficiency:	--
Voltage:	460	KVA Code:	G
Hertz:	60	Max KVAR:	39.2
Amps - FL:	264.0	Power Factor:	92.5
Service Factor:	1.15	Bearing - DE:	6314ZC3
Alt Service Factor:	--	Bearing - ODE:	6314ZC3

Enclosure is Totally Enclosed Fan-Cooled

Stamped Nameplate Notes:

FOR DIRECT COUPLED LOAD ONLY
 DE BRG 70BC03JP30, ODE BRG 70BC03JP30
 ROT CW FACING ODE LEAD/PH SEQ 1-2-3/1-2-3
 STAMP NP249A5564P051 AS BELOW:
 MODEL:5KS449XAA123D9 S/N: XXX
 CSA CERTIFIED CSA09.2216219 FOR EX NA IIC 200 C GC
 CL 1 ZONE2 AEX NA IIC 200C;CL 1 DIV2 GRP ABCD 200C
 IN -25C <= AMB <= 40C, 1.0 SF ON SINE-WAVE PWR
 SURF TEMP 215C AT 1.15SF ON SINE-WAVE PWR
 OR 200 C VT OR 215 C CT OR --- C CHP PWM CONTROL
 ALTERNATE RATING FOR PWM CONTROL 1.0SF 40C AMB
 VT 0-60 HZ, CT 45-60 HZ, CHP --- HZ.
 EXCEPTION TO IEEE-STD-841-2009:SOUND POWER 94 DBA



Additional Information:

2P - TS EXTN - SPLIT LEAD
PAINTED FRAME ID & SHAFT,
FAN COVER INSIDE & ODE E/S OUTSIDE
C/BOX 1260 CU IN - 2(4.00" NPT)
C/B GRD PLATE
INPRO SEAL BOTH ENDS
OIL RESISTANT SLEEVING ON LEADS
.0015" TIR SHAFT RUNOUT
ROUTINE TEST REPORT AND 5 POINT VIBRATION TEST
REPORT INCLUDED IN C/B
COPPER WASHER UNDER HEADS OF BEARING CAP BOLTS,
APPLY TITE-SEAL (A50CD427A) ON BEARING CAP SCREWS,
RABBETS AND PLUG THREADS.
GROUND PAD
F1 MOUNTING



Performance Characteristics

1st Winding 1st Connection

Design: 49BD0193A

Marks:

LOAD %	125.0	115.0	100.0	75.0	50.0	25.0	0.0
% EFF	95.5	95.7	96.15	96.17	95.93	94.01	0.00
% PF	92.15	92.29	92.28	91.3	87.55	72.84	5.84
AMPS	332.36	304.66	263.75	199.87	139.3	85.42	54.67

TORQ(FL)#FT	366.7	TORQ(LR)%FL	96.09	TORQ(BD)%FL	305.12
AMPS(LR)	1709.42	PF AT START	0.18		

This motor is capable of two cold or one hot start with a maximum connected load inertia of 725 Lb-Ft Sq (30.52 Kg-meter Sq)at 100% voltage, where the load torque varies with the square of the speed. Acceleration time with maximum inertia and the above load type is 42 seconds. Safe stall time at 100% voltage is 98 seconds cold, 50 seconds hot. Rotor inertia is 48.07 Lb-Ft Sq (2.02 Kg-meter Sq).

Open Circuit A-C:	2.243	Short Circuit D-C:	0.037
Short Circuit A-C:	0.075	X/R Ratio:	13.782
Stator Slots:	48	Rotor Slots:	38

Speed Torque Current Curve (First Connection, First Speed)

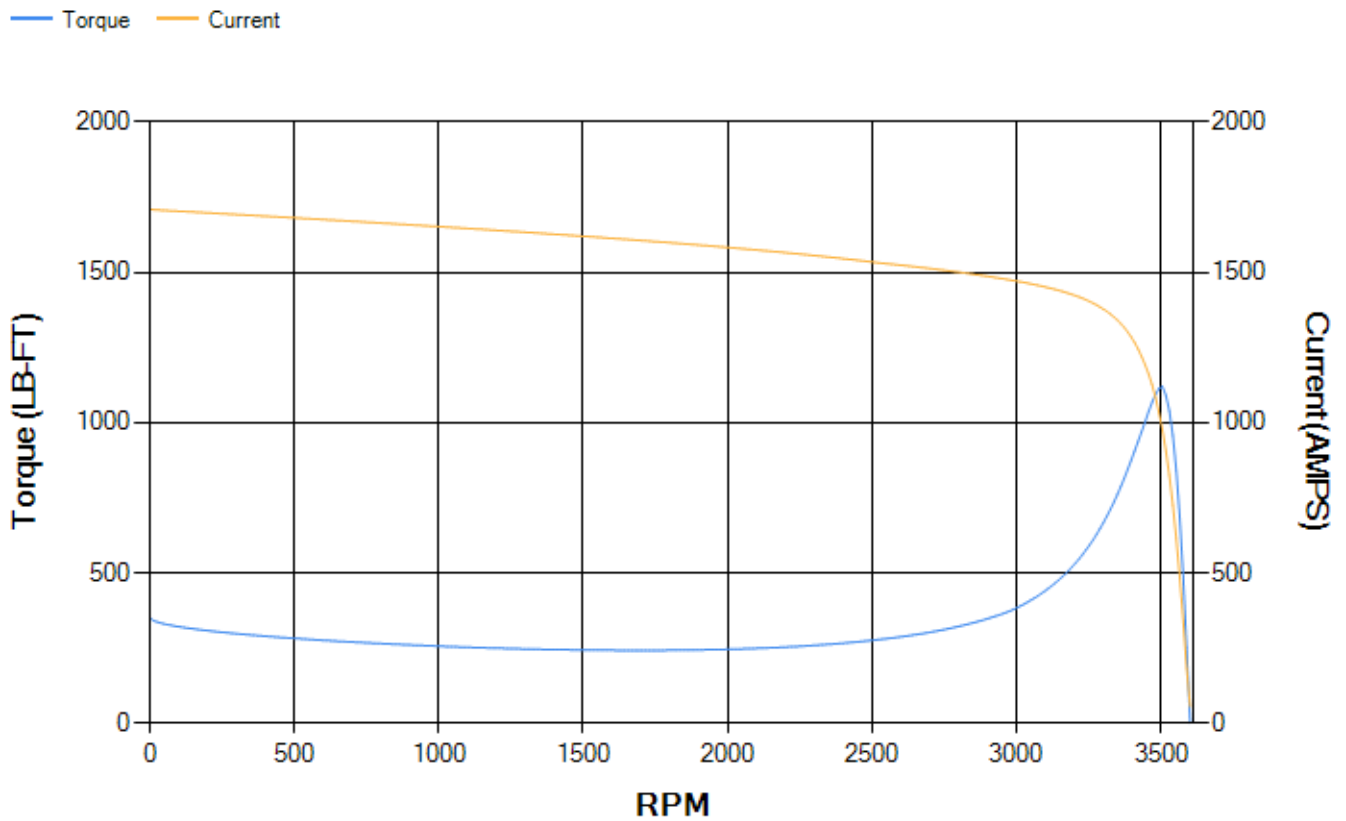

Marks:

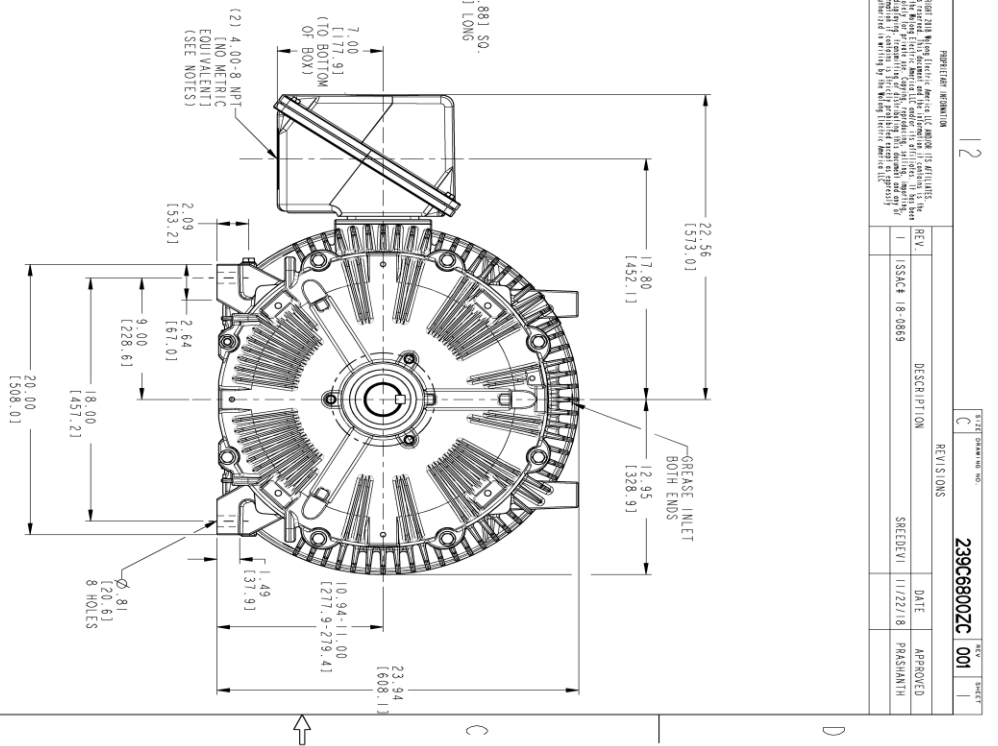
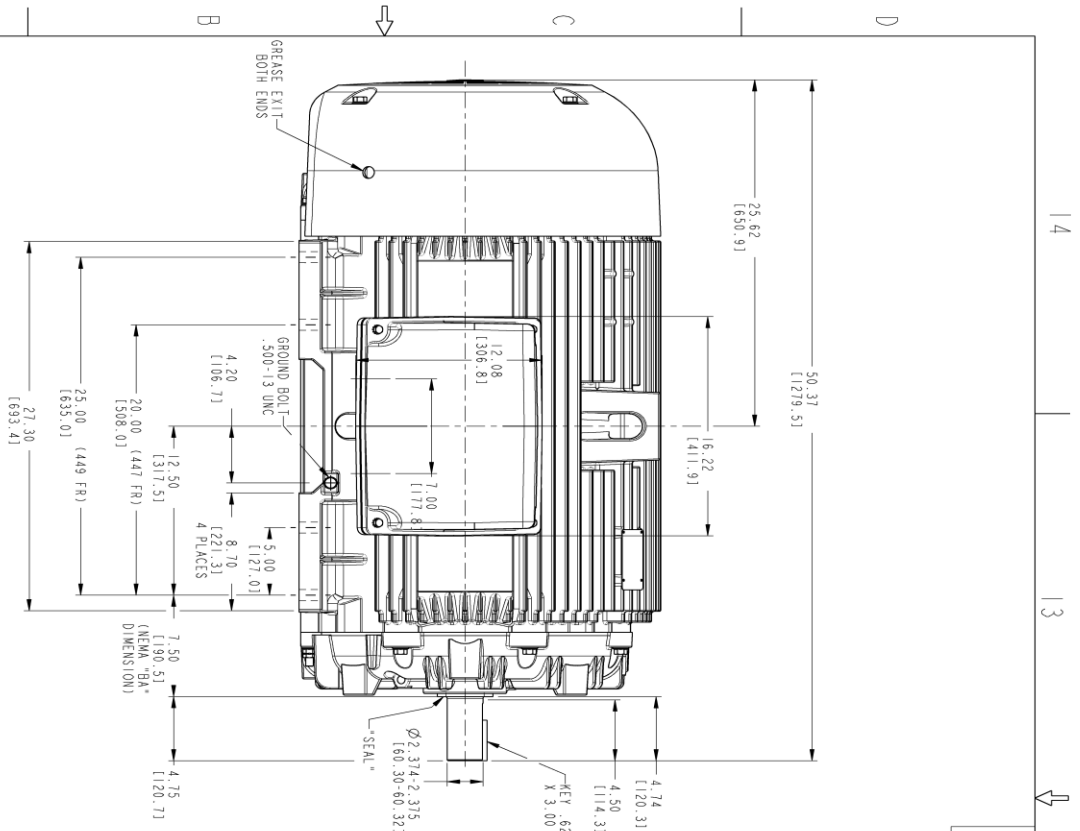

REVISION INFORMATION

REV.	DESCRIPTION	DATE	APPROVED
1	ISSUE 18-0869	11/22/18	PARSHANTH

239C6800ZC 001

- NOTES:
1. CONDUIT BOX MAY BE PLACED WITH THE ENTRANCE DOWN, UP OR ON EITHER SIDE.
 2. F-1 ASSEMBLY AS SHOWN.
 3. F-2 ASSEMBLY CONDUIT BOX ON OPPOSITE SIDE.
 4. ALL DIMENSIONS ARE IN INCHES. BRACKETED DIMENSIONS ARE METRIC (MILLIMETERS).
 5. TOLERANCE ON PERMISSIBLE SHAFT EXTENSION ROUNDOFF IS .0015 T.I.R.



SIGNATURES	DATE	TITLE
MODEL: TEJASNI	08/10/15	<p>GE INDUSTRIAL MOTORS A WOLSKEL COMPANY</p> <p>OUTLINE</p> <p>447/449 TS TEFC XSD 841</p> <p>280 CU. IN. C. BOX, GROUND PAD</p> <p>239C6800ZC</p>
REVIEW: TEJASNI	08/10/15	
CHECKED: ANIL	08/10/15	
DESIGN: ANIL	08/10/15	
DATE: 08/10/15		
ISSUED: TEJASNI	08/10/15	SCALE: 0.180
SIZE: C		REF. NO.:
QUALITY: 001		SHEET 1 OF 1

Marks:

Connection Diagram
GEM2034E-FIG20

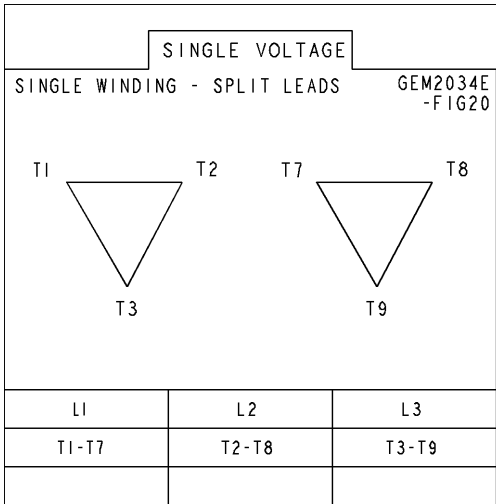

End shield Assembly		
Part Description	DE Side Part#	ODE Side Part#
End Shield	115E4354AA1	115E4354LL1
Bearing	235A2516AC01	235A2516AC01
Slinger/Inproseal	235A4575GS3	235A4575GS3

Fan & Fan Cover Assembly	
Part Description	Part#
Fan	149C4261AK2
Fan Cover	128D6841AC1

Conduit & Accessories Box Assembly	
Part Description	Part#
Conduit Box	179B9058G03

Mechanical Accessories	
Part Description	Part#
Brake	
Tachometer	

