



**GE INDUSTRIAL MOTORS**  
a **WOLONG** company

# Product Technical Information

March 7, 2021

Data shown is for the current revision model #. Ensure your nameplate model # matches.

<b>Model Number:</b>	<b>5KS215SAA305D2</b>
<b>Catalog Number:</b>	<b>M9143</b>
<b>Instruction Manual:</b>	GEI-56128
<b>Connection Diagram:</b>	GEM2034E-FIG3
<b>Outline Drawing:</b>	4002B5821PAP5616

## Accessory Connection Diagrams

<b>Bearing Thermocouple:</b>	None	<b>Heater:</b>	None
<b>RTD:</b>	None	<b>Thermistor:</b>	None
<b>Thermostat:</b>	None	<b>Winding Thermocouple:</b>	None
<b>Bearing RTD:</b>	None		

## Table of Contents

Specification	01
Performance Characteristics	02
Outline Drawing	03
Connection Drawing(s)	04
Spare parts	05

Marks:

<b>MODEL NUMBER:</b>	<b>5KS215SAA305D2</b>	<b>Estimated Weight:</b>	220 Lbs
<b>Outline Drawing:</b>	4002B5821PAP5616	<b>Time Rating:</b>	CONT
<b>Connection Diagram:</b>	GEM2034E-FIG3	<b>Enclosure:</b>	TEFC
<b>Instruction Book:</b>	GEI-56128	<b>Encl Construction:</b>	841
<b>Design Code:</b>	21BD3104A	<b>Ambient Max(°C):</b>	40
<b>Type:</b>	KS	<b>Alt Ambient Max(°C):</b>	--
<b>Frame:</b>	215T	<b>Insulation Class:</b>	H
<b>Phases:</b>	3	<b>NEMA Design:</b>	B
<b>Poles:</b>	6	<b>Nominal Efficiency:</b>	89.5 %
<b>Output Power:</b>	5HP 3.7KW	<b>Guaranteed Efficiency:</b>	88.5 %
<b>RPM:</b>	1175	<b>3/4 Load Efficiency:</b>	--
<b>Voltage:</b>	230/460	<b>KVA Code:</b>	J
<b>Hertz:</b>	60	<b>Max KVAR:</b>	2.3
<b>Amps - FL:</b>	13.8/6.9	<b>Power Factor:</b>	76.0
<b>Service Factor:</b>	1.15	<b>Bearing - DE:</b>	6208ZC3
<b>Alt Service Factor:</b>	--	<b>Bearing - ODE:</b>	6208ZC3

Enclosure is Totally Enclosed Fan-Cooled

---

Stamped Nameplate Notes:

DE BRG 40BC02JP30 ODE BRG 40BC02JP30  
 EXCEPTION TO IEEE-STD-841-2009: DUAL VOLTAGE  
 STAMP NP249A5564P051 AS BELOW:  
 MODEL:5KS215SAA305D2 S/N: XXX  
 CSA CERTIFIED CSA09.2216219 FOR EX NA IIC 200C GC  
 CL 1 ZONE2 AEX NA IIC 200C;CL 1 DIV2 GRP ABCD 200C  
 IN -40C <= AMB <= 40C, 1.0 SF ON SINE-WAVE PWR  
 SURF TEMP 200C AT 1.15SF ON SINE-WAVE PWR  
 OR 200C VT OR 200C CT OR 200C CHP PWM CONTROL  
 ALTERNATE RATING FOR PWM CONTROL 1.0SF 40C AMB  
 VT 0 - 60 HZ, CT 3-60 HZ, CHP 60-90 HZ.



**Additional Information:**

6P - T EXTN  
STANDARD FLOOR MOUNT  
C/BOX 55 CU IN-1.00 NPT  
F1 CONDUIT BOX MOUNTING  
PAINTED FRAME ID & SHAFT,  
FAN COVER INSIDE & ODE E/S OUTSIDE  
ROUTINE AND 5 POINT VIBRATION TESTS INCL IN C/BOX  
GROUND SCREW ON FRAME  
SHAFT RUNOUT LIMIT .001" TIR  
OIL RESISTANT SLEEVING ON LEADS



**Performance Characteristics**

1st Winding 1st Connection

**Design: 21BD3104A**

**Marks:**

LOAD %	125.0	115.0	100.0	75.0	50.0	25.0	0.0
% EFF	88.56	89.18	90.13	90.63	90.16	85.86	0.00
% PF	78.62	77.8	75.87	69.97	58.49	37.45	4.98
AMPS	8.4	7.76	6.84	5.53	4.44	3.64	3.26

<b>TORQ(FL)#FT</b>	22.38	<b>TORQ(LR)%FL</b>	201.85	<b>TORQ(BD)%FL</b>	302.74
<b>AMPS(LR)</b>	45.61	<b>PF AT START</b>	0.46		

This motor is capable of two cold or one hot start with a maximum connected load inertia of 575 Lb-Ft Sq (24.21 Kg-meter Sq)at 100% voltage, where the load torque varies with the square of the speed. Acceleration time with maximum inertia and the above load type is 52 seconds. Safe stall time at 100% voltage is 115 seconds cold, 83 seconds hot. Rotor inertia is 0.9 Lb-Ft Sq (0.04 Kg-meter Sq).

<b>Open Circuit A-C:</b>	0.236	<b>Short Circuit D-C:</b>	0.01
<b>Short Circuit A-C:</b>	0.014	<b>X/R Ratio:</b>	3.662
<b>Stator Slots:</b>	36	<b>Rotor Slots:</b>	44

**Speed Torque Current Curve (First Connection, First Speed)**

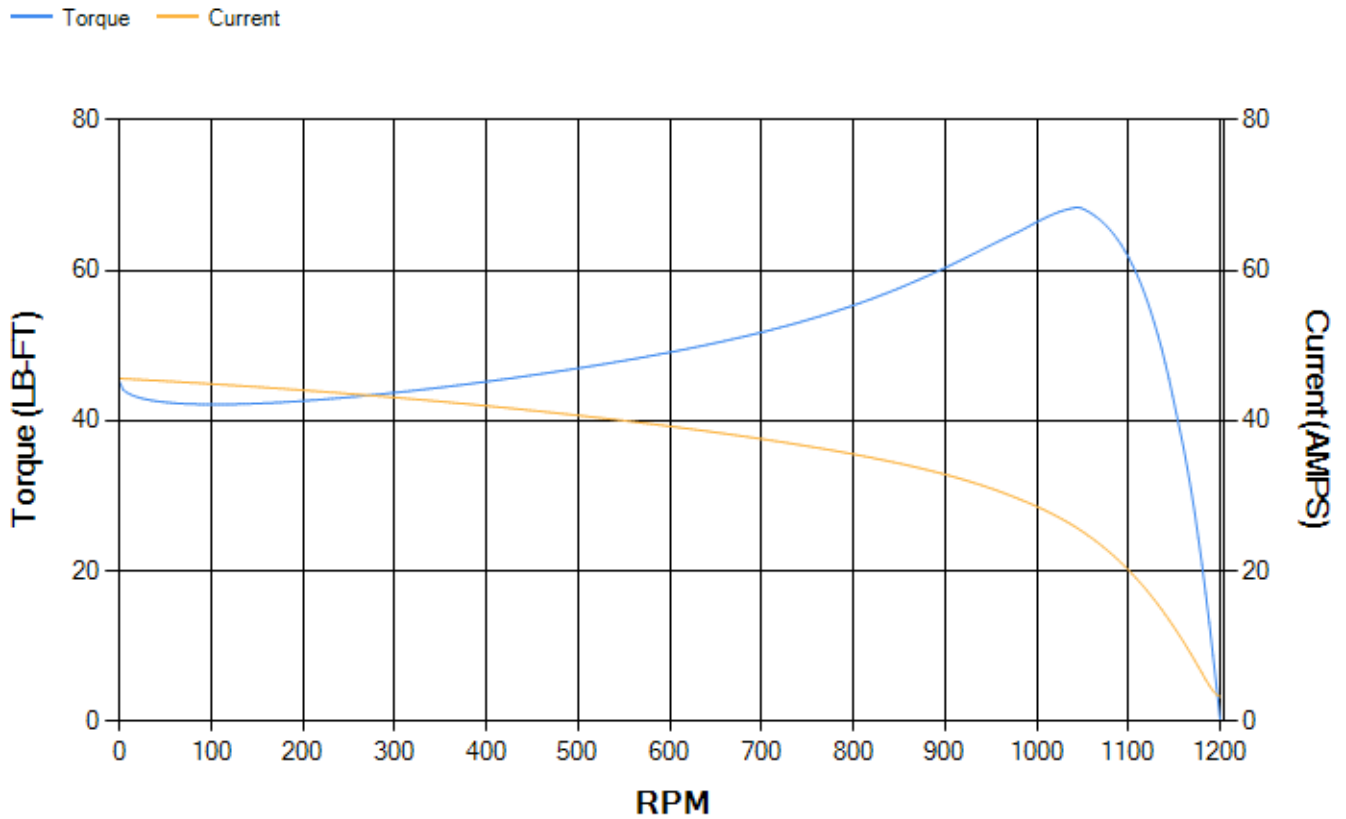

Marks:

NOTE 1: CONDUIT BOX MAY BE ASSEMBLED WITH ENTRANCE UP, DOWN OR TO EITHER SIDE.  
 NOTE 2: F1 ASSEMBLY AS SHOWN. F2 ASSEMBLY CONDUIT BOX ON OPPOSITE SIDE FROM SHOWN LOCATION.  
 NOTE 3: ALL DIMENSIONS ARE IN INCHES AND BRACKETED DIMENSIONS ARE IN METRIC (MILLIMETERS).

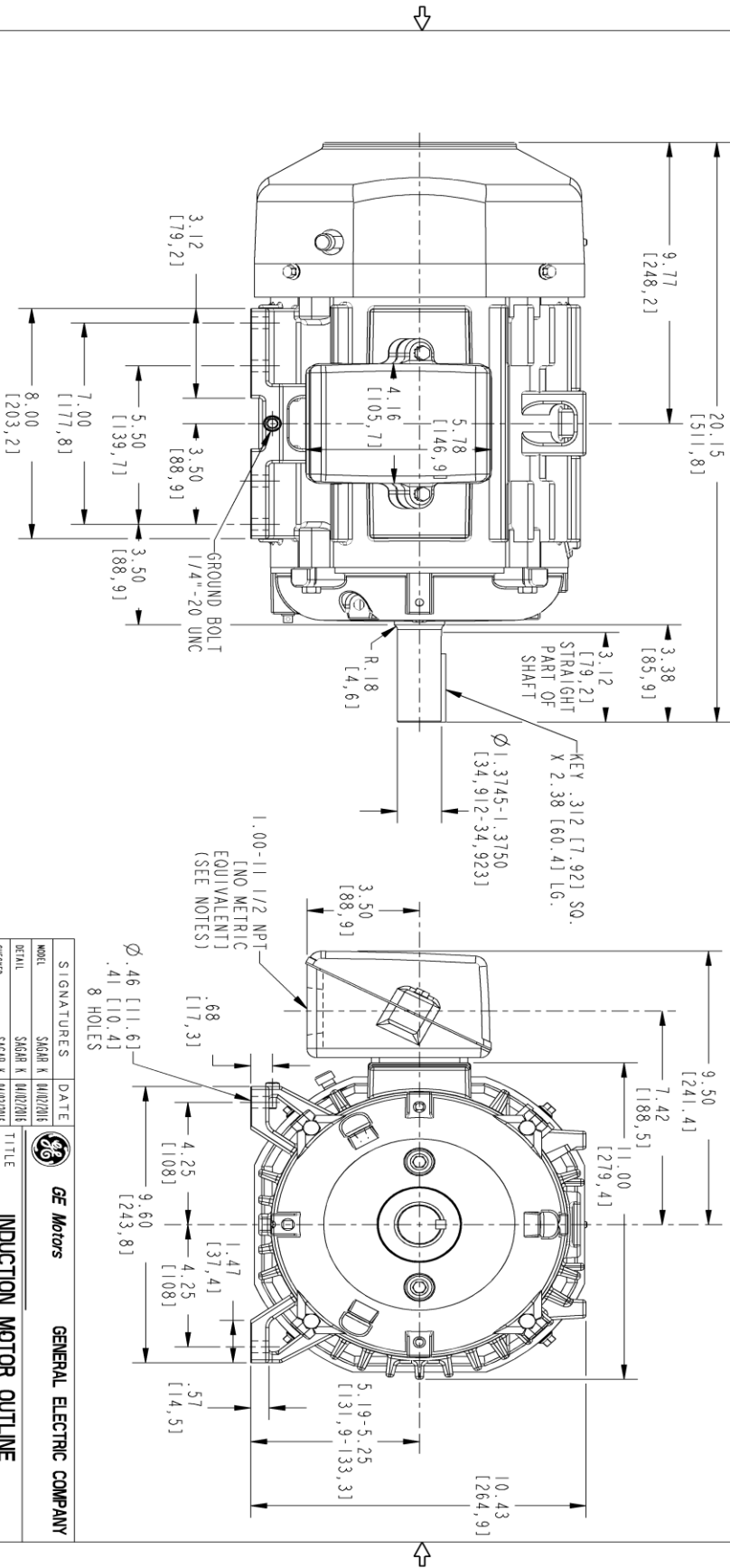

SIZE	DRAWING NO.	REV	SHEET
B	4002B5821PAP5616	0	1

REV.	DESCRIPTION	DATE	APPROVED

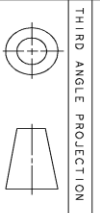

THIRD ANGLE PROJECTION

SIGNATURES	DATE	<b>GE Motors</b> GENERAL ELECTRIC COMPANY
MODEL: SAGAR K. [4/10/2016] DETAIL: SAGAR K. [4/10/2016] CHECKED: SAGAR K. [4/10/2016] ENG'D: - WEC: - QUALITY: - ISSUED: SAGAR K. [4/10/2016]	TITLE: <b>INDUCTION MOTOR OUTLINE</b> STANDARD CONSTRUCTION WITH GROUND PAD FR213/215 T TEFC <b>4002B5821PAP5616</b>	
SIZE: DRAWING: B SCALE: 0.300 REF. No.: 4002B5821PAP5311	REV: 0	SHEET 1 of 1

Marks:

**Connection Diagram**  
**GEM2034E-FIG3**

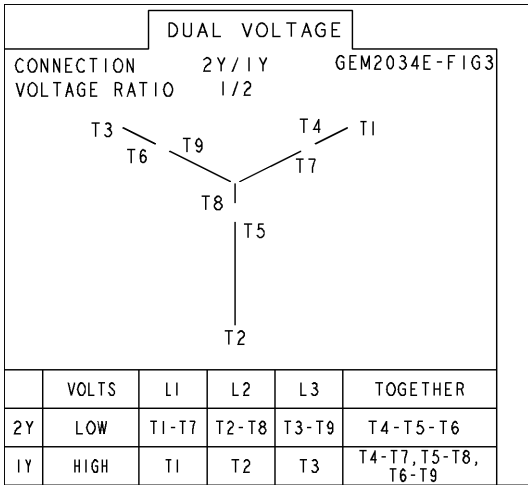

End shield Assembly		
Part Description	DE Side Part#	ODE Side Part#
End Shield	4004D5282PB1	4004D5282SJ1
Bearing	235A2503AE01	235A2503AE01
Slinger/Inproseal	149C4399G01	149C4399G01

Fan & Fan Cover Assembly	
Part Description	Part#
Fan	159C6700G01
Fan Cover	4003C5787PA1

Conduit & Accessories Box Assembly	
Part Description	Part#
Conduit Box	4002B5721PA-G01

Mechanical Accessories	
Part Description	Part#
Brake	
Tachometer	

