



GE INDUSTRIAL MOTORS
a **WOLONG** company

Product Technical Information

May 6, 2021

Data shown is for the current revision model #. Ensure your nameplate model # matches.

Model Number:	5KS213SAA205D3
Catalog Number:	M9145
Instruction Manual:	GEI-56128
Connection Diagram:	GEM2034E-FIG9
Outline Drawing:	4002B5821PAP5616

Accessory Connection Diagrams

Bearing Thermocouple:	None	Heater:	None
RTD:	None	Thermistor:	None
Thermostat:	None	Winding Thermocouple:	None
Bearing RTD:	None		

Table of Contents

Specification	01
Performance Characteristics	02
Outline Drawing	03
Connection Drawing(s)	04
Spare parts	05

Marks:

MODEL NUMBER:	5KS213SAA205D3	Estimated Weight:	200 Lbs
Outline Drawing:	4002B5821PAP5616	Time Rating:	CONT
Connection Diagram:	GEM2034E-FIG9	Enclosure:	TEFC
Instruction Book:	GEI-56128	Encl Construction:	841
Design Code:	21BD1152A	Ambient Max(°C):	40
Type:	KS	Alt Ambient Max(°C):	--
Frame:	213T	Insulation Class:	H
Phases:	3	NEMA Design:	B
Poles:	4	Nominal Efficiency:	91.7 %
Output Power:	7.5HP 5.6KW	Guaranteed Efficiency:	91.0 %
RPM:	1770	3/4 Load Efficiency:	--
Voltage:	230/460	KVA Code:	H
Hertz:	60	Max KVAR:	2.3
Amps - FL:	18.4/9.2	Power Factor:	83.5
Service Factor:	1.15	Bearing - DE:	6208ZC3
Alt Service Factor:	--	Bearing - ODE:	6208ZC3

Enclosure is Totally Enclosed Fan-Cooled

Stamped Nameplate Notes:

DE BRG 40BC02JP30 ODE BRG 40BC02JP30
 EXCEPTION TO IEEE-STD-841-2009: DUAL VOLTAGE
 STAMP NP249A5564P051 AS BELOW:
 MODEL:5KS213SAA205D3 S/N: XXX
 CSA CERTIFIED CSA09.2216219 FOR EX NA IIC 200C GC
 CL 1 ZONE2 AEX NA IIC 200C;CL 1 DIV2 GRP ABCD 200C
 IN -40C <= AMB <= 40C, 1.0 SF ON SINE-WAVE PWR
 SURF TEMP 215C AT 1.15SF ON SINE-WAVE PWR
 OR 200C VT OR 200C CT OR 200C CHP PWM CONTROL
 ALTERNATE RATING FOR PWM CONTROL 1.0SF 40C AMB
 VT 0-60 HZ, CT 3-60 HZ, CHP 60-90 HZ.



Additional Information:

4P - T EXTN
STANDARD FLOOR MOUNT
C/BOX 55 CU IN-1.00 NPT
F1 CONDUIT BOX MOUNTING
PAINTED FRAME ID & SHAFT,
FAN COVER INSIDE & ODE E/S OUTSIDE
ROUTINE AND 5 POINT VIBRATION TESTS INCL IN C/BOX
GROUND SCREW ON FRAME
SHAFT RUNOUT LIMIT .001" TIR
OIL RESISTANT SLEEVING ON LEADS



Performance Characteristics

1st Winding 1st Connection

Design: 21BD1152A

Marks:

LOAD %	125.0	115.0	100.0	75.0	50.0	25.0	0.0
% EFF	90.56	91.05	91.84	92.16	91.68	87.87	0.00
% PF	84.59	84.42	83.64	80.28	71.83	50.93	6.5
AMPS	11.45	10.5	9.14	7.12	5.33	3.92	3.22

TORQ(FL)#FT	22.25	TORQ(LR)%FL	192.5	TORQ(BD)%FL	282.87
AMPS(LR)	61.27	PF AT START	0.4		

This motor is capable of two cold or one hot start with a maximum connected load inertia of 306 Lb-Ft Sq (12.88 Kg-meter Sq) at 100% voltage, where the load torque varies with the square of the speed. Acceleration time with maximum inertia and the above load type is 54 seconds. Safe stall time at 100% voltage is 120 seconds cold, 89 seconds hot. Rotor inertia is 0.99 Lb-Ft Sq (0.04 Kg-meter Sq).

Open Circuit A-C:	0.448	Short Circuit D-C:	0.013
Short Circuit A-C:	0.021	X/R Ratio:	4.936
Stator Slots:	36	Rotor Slots:	28

Speed Torque Current Curve (First Connection, First Speed)

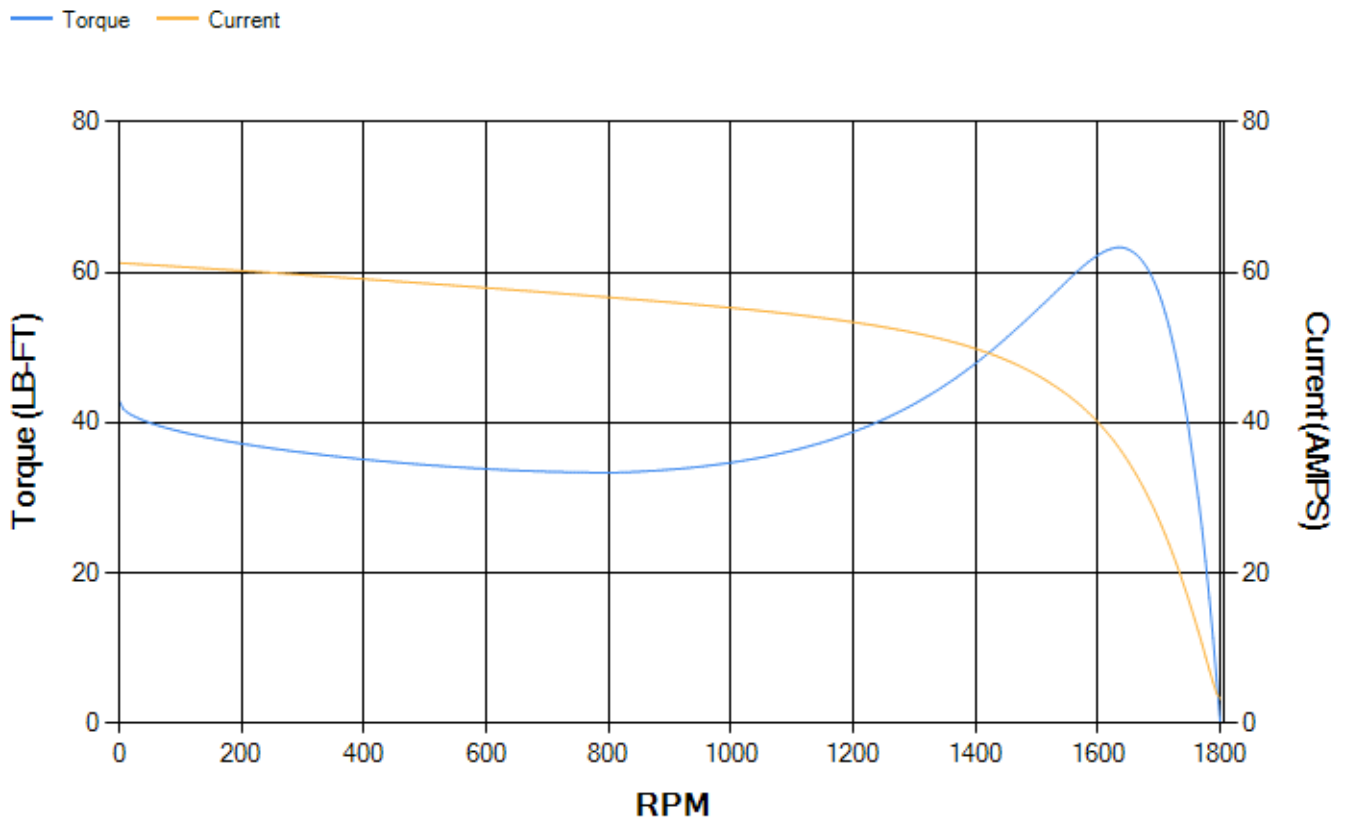

Marks:

NOTE 1: CONDUIT BOX MAY BE ASSEMBLED WITH ENTRANCE UP, DOWN OR TO EITHER SIDE.
 NOTE 2: F1 ASSEMBLY AS SHOWN. F2 ASSEMBLY CONDUIT BOX ON OPPOSITE SIDE FROM SHOWN LOCATION.
 NOTE 3: ALL DIMENSIONS ARE IN INCHES AND BRACKETED DIMENSIONS ARE IN METRIC (MILLIMETERS).

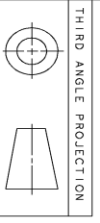
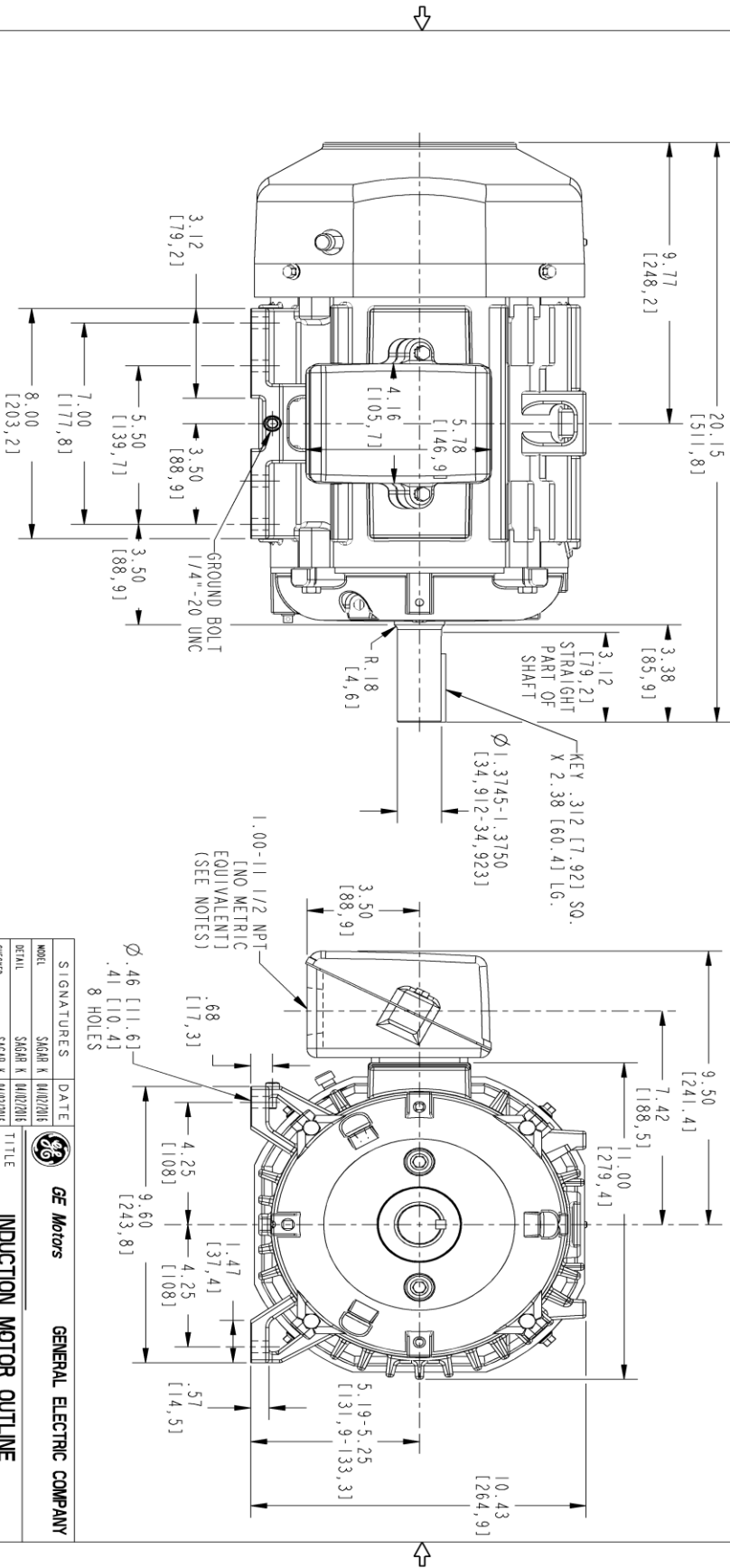

THIRD ANGLE PROJECTION

SIZE DRAWING NO. B

4002B5821PAP5616 0

REV SHEET 1

REV.	DESCRIPTION	DATE	APPROVED

REVISIONS

SIGNATURES	DATE	GE Motors GENERAL ELECTRIC COMPANY
MODEL: SGA8 K [4402206] DETAIL: SGA8 K [4402206] CHECKED: SGA8 K [4402206] ENG'D: - WEC: - QUALITY: - ISSUED: SGA8 K [4402206]	TITLE: INDUCTION MOTOR OUTLINE STANDARD CONSTRUCTION WITH GROUND PAD FR213/215 T TFC 4002B5821PAP5616	
SIZE DRAWING: B SCALE: 0.300 REF. No. 4002B5821PAP5311	REV: 0 SHEET 1 of 1	

Marks:

Connection Diagram
GEM2034E-FIG9



End shield Assembly		
Part Description	DE Side Part#	ODE Side Part#
End Shield	4004D5282PB1	4004D5282SJ1
Bearing	235A2503AE01	235A2503AE01
Slinger/Inproseal	149C4399G01	149C4399G01

Fan & Fan Cover Assembly	
Part Description	Part#
Fan	159C6700G01
Fan Cover	4003C5787PA1

Conduit & Accessories Box Assembly	
Part Description	Part#
Conduit Box	4002B5721PA-G01

Mechanical Accessories	
Part Description	Part#
Brake	
Tachometer	

