



GE INDUSTRIAL MOTORS
a **WOLONG** company

Product Technical Information

April 1, 2021

Data shown is for the current revision model #. Ensure your nameplate model # matches.

Model Number:	5KS256SAA305D2
Catalog Number:	M9149
Instruction Manual:	GEI-56128
Connection Diagram:	GEM2034E-FIG3
Outline Drawing:	4002B5825PAP5992

Accessory Connection Diagrams

Bearing Thermocouple:	None	Heater:	None
RTD:	None	Thermistor:	None
Thermostat:	None	Winding Thermocouple:	None
Bearing RTD:	None		

Table of Contents

Specification	01
Performance Characteristics	02
Outline Drawing	03
Connection Drawing(s)	04
Spare parts	05

Marks:

MODEL NUMBER:	5KS256SAA305D2	Estimated Weight:	350 Lbs
Outline Drawing:	4002B5825PAP5992	Time Rating:	CONT
Connection Diagram:	GEM2034E-FIG3	Enclosure:	TEFC
Instruction Book:	GEI-56128	Encl Construction:	841
Design Code:	25BD3100A	Ambient Max(°C):	40
Type:	KS	Alt Ambient Max(°C):	--
Frame:	256T	Insulation Class:	H
Phases:	3	NEMA Design:	B
Poles:	6	Nominal Efficiency:	91.0 %
Output Power:	10HP 7.4KW	Guaranteed Efficiency:	90.2 %
RPM:	1175	3/4 Load Efficiency:	--
Voltage:	230/460	KVA Code:	H
Hertz:	60	Max KVAR:	4.2
Amps - FL:	26.0/13.0	Power Factor:	79.0
Service Factor:	1.15	Bearing - DE:	6309ZC3
Alt Service Factor:	--	Bearing - ODE:	6309ZC3

Enclosure is Totally Enclosed Fan-Cooled

Stamped Nameplate Notes:

DE BRG 45BC03JP30 ODE BRG 45BC03JP30
 EXCEPTION TO IEEE-STD-841-2009: DUAL VOLTAGE
 STAMP NP249A5564P051 AS BELOW:
 MODEL:5KS256SAA305D2 S/N: XXX
 CSA CERTIFIED CSA09.2216219 FOR EX NA IIC 200C GC
 CL 1 ZONE2 AEX NA IIC 200C;CL 1 DIV2 GRP ABCD 200C
 IN -40C <= AMB <= 40C, 1.0 SF ON SINE-WAVE PWR
 SURF TEMP 200 C AT 1.15SF ON SINE-WAVE PWR
 OR 200 C VT OR 200 C CT OR 200 C CHP PWM CONTROL
 ALTERNATE RATING FOR PWM CONTROL 1.0SF 40C AMB
 VT 0 - 60 HZ, CT 3-60 HZ, CHP 60-90 HZ.



Additional Information:

6P - T EXTN
STANDARD FLOOR MOUNT
C/BOX 137 CU IN-1.25 NPT
F1 CONDUIT BOX MOUNTING
PAINTED FRAME ID & SHAFT,
FAN COVER INSIDE & ODE E/S OUTSIDE
ROUTINE AND 5 POINT VIBRATION TESTS INCL IN C/BOX
GROUND SCREW ON FRAME
SHAFT RUNOUT LIMIT .001" TIR
OIL RESISTANT SLEEVING ON LEADS



Performance Characteristics

1st Winding 1st Connection

Design: 25BD3100A

Marks:

LOAD %	125.0	115.0	100.0	75.0	50.0	25.0	0.0
% EFF	90.18	90.66	91.45	91.79	91.32	87.41	0.00
% PF	81.81	80.99	79.13	73.48	62.17	40.31	4.8
AMPS	15.86	14.66	12.94	10.41	8.24	6.64	5.89

TORQ(FL)#FT	44.74	TORQ(LR)%FL	215.09	TORQ(BD)%FL	286.64
AMPS(LR)	83.8	PF AT START	0.41		

This motor is capable of two cold or one hot start with a maximum connected load inertia of 976 Lb-Ft Sq (41.09 Kg-meter Sq)at 100% voltage, where the load torque varies with the square of the speed. Acceleration time with maximum inertia and the above load type is 43 seconds. Safe stall time at 100% voltage is 96 seconds cold, 66 seconds hot. Rotor inertia is 1.99 Lb-Ft Sq (0.08 Kg-meter Sq).

Open Circuit A-C:	0.249	Short Circuit D-C:	0.011
Short Circuit A-C:	0.015	X/R Ratio:	4.232
Stator Slots:	54	Rotor Slots:	42

Speed Torque Current Curve (First Connection, First Speed)

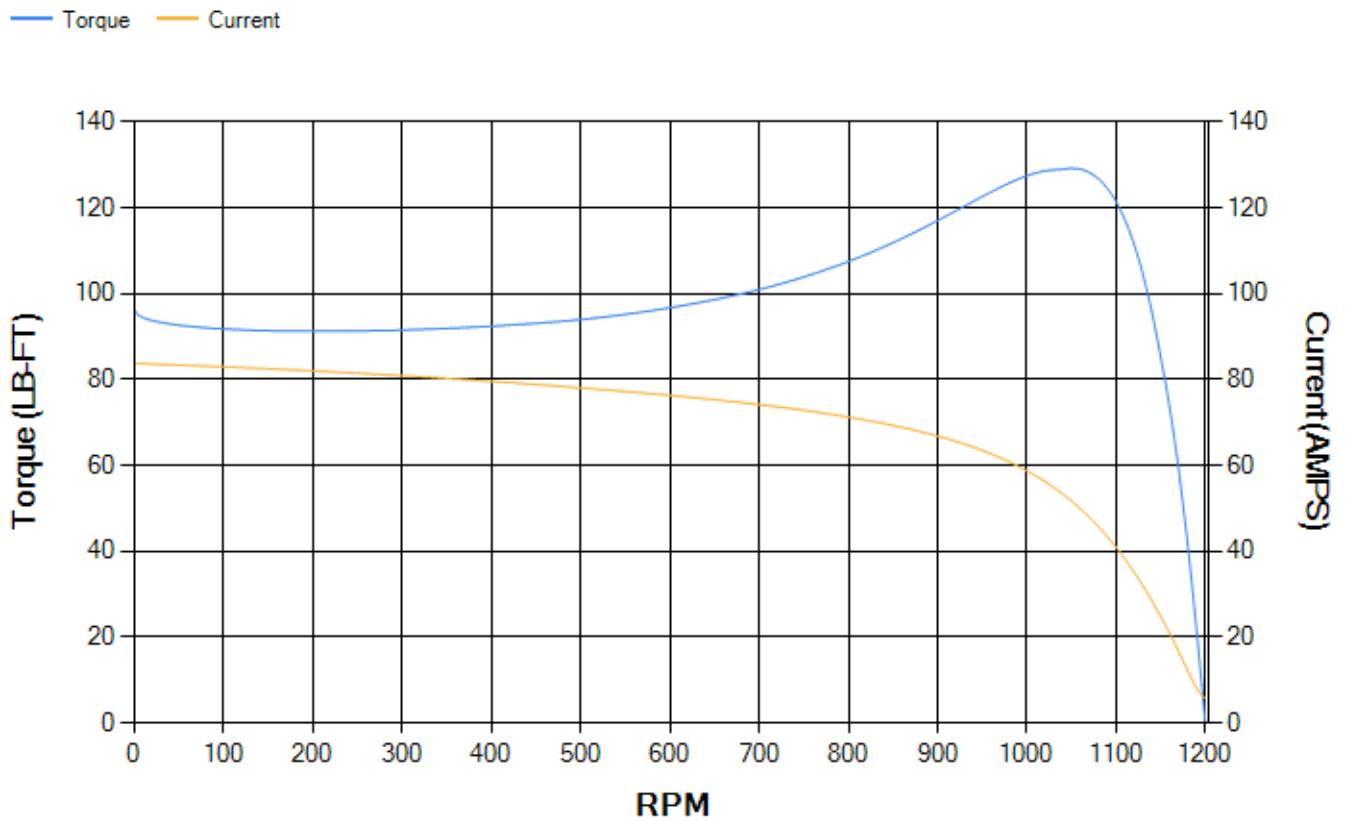

Marks:

NOTE 1: CONDUIT BOX MAY BE ASSEMBLED WITH ENTRANCE UP, DOWN OR TO EITHER SIDE.
 NOTE 2: FIT ASSEMBLY AS SHOWN.
 NOTE 3: ALL DIMENSIONS ARE IN INCHES, BRACKETED DIMENSIONS ARE IN METRIC (MILLIMETERS)

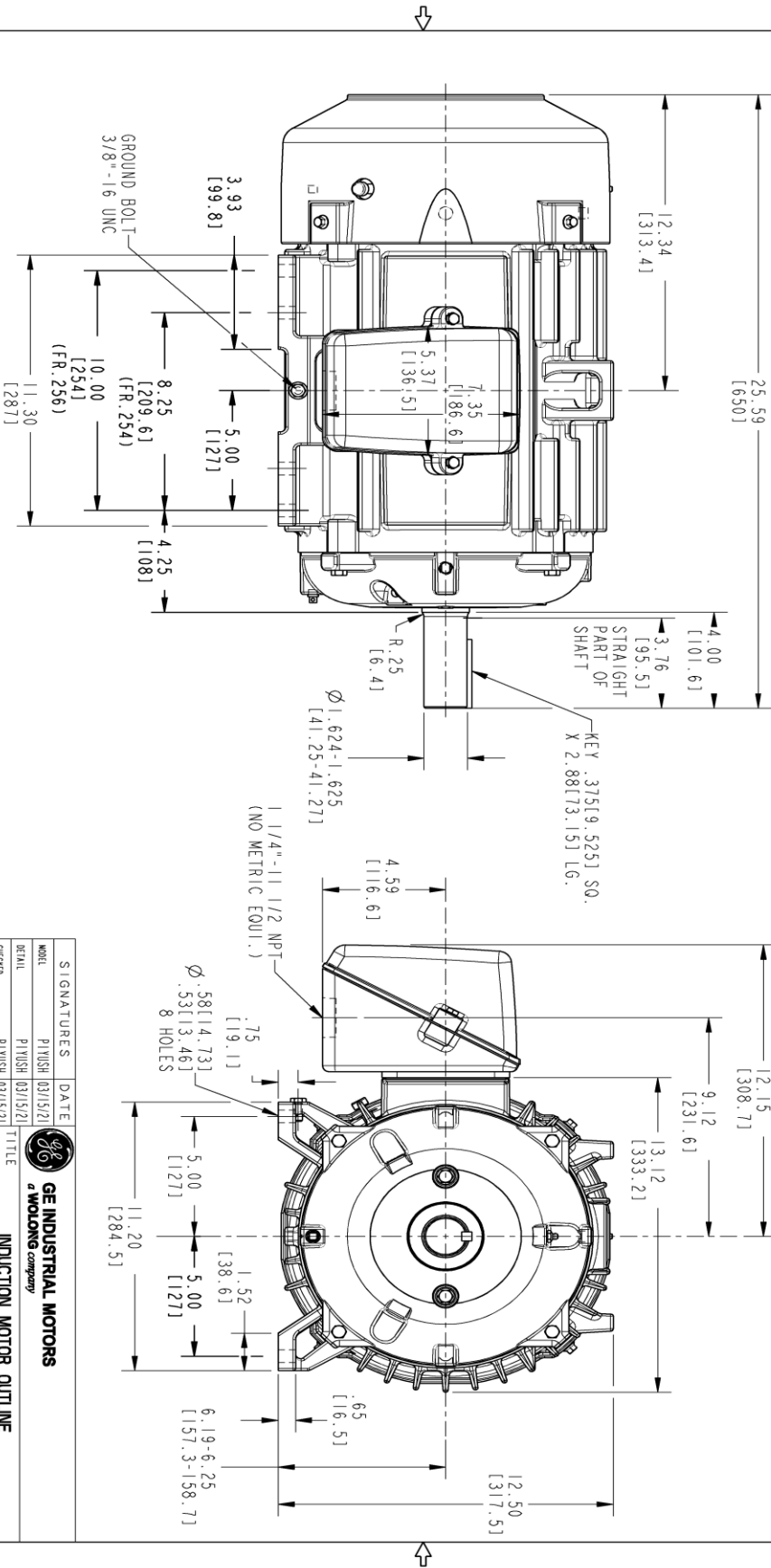

PROPRIETARY INFORMATION
 © COPYRIGHT 2018 Molong Electric America LLC AND/OR ITS AFFILIATES.
 All rights reserved. This document and the information it contains is the property of Molong Electric America LLC and/or its affiliates. It has been provided solely for the use of the customer and is not to be distributed, copied, or otherwise used without the express written consent of Molong Electric America LLC. Any use of this information for any other purpose is strictly prohibited except as expressly authorized in writing by Molong Electric America LLC.

REV.	DESCRIPTION	DATE	APPROVED

SIZE: DRAWING NO. B	REV. 000	SHEET 1
4002B5825PAP5992		
REVISONS		

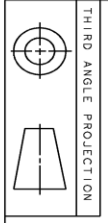

SIGNATURES	DATE	<p>GE INDUSTRIAL MOTORS a molong company</p> <p>INDUCTION MOTOR OUTLINE STANDARD CONSTRUCTION, GROUND PAD</p> <p>FIN: FR250T TFC</p>
MODEL	03/15/21	
DETAIL	PIVUSH 03/15/21	
CREATED	PIVUSH 03/15/21	
ENGR	PIVUSH 03/15/21	
QUALITY	PIVUSH 03/15/21	SCALE: 0.250
ISSUED	B	REV. 000
SOLID MODEL: 4002B5825PAP5992	SIZE: DRAWING	4002B5825PAP5992
		REV. 000
		SHEET 1 OF 1

Marks:

Connection Diagram
GEM2034E-FIG3

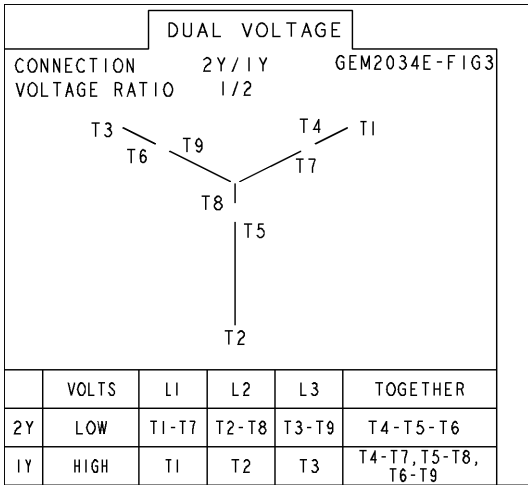

End shield Assembly		
Part Description	DE Side Part#	ODE Side Part#
End Shield	4004D5283PB1	4004D5283SE1
Bearing	235A2507EB01	235A2507EB01
Slinger/Inproseal	149C4399G02	149C4399G02

Fan & Fan Cover Assembly	
Part Description	Part#
Fan	159C6800G01
Fan Cover	4003C5788PA1

Conduit & Accessories Box Assembly	
Part Description	Part#
Conduit Box	4002B5728PA-G04

Mechanical Accessories	
Part Description	Part#
Brake	
Tachometer	

